



FCC RF Test Report

APPLICANT : TCL Communication Ltd.
EQUIPMENT : Tablet PC
BRAND NAME : alcatel
MODEL NAME : 9015B
MARKETING NAME : Alcatel POP™ 7 LTE
FCC ID : 2ACCJB066
STANDARD : FCC Part 15 Subpart E §15.407
CLASSIFICATION : (NII) Unlicensed National Information Infrastructure

The product was received on Jul. 05, 2016 and testing was completed on Aug. 02, 2016. We, SPORTON INTERNATIONAL (SHENZHEN) INC., would like to declare that the tested sample has been evaluated in accordance with the test procedures and has been in compliance with the applicable technical standards.

The test results in this report apply exclusively to the tested model / sample. Without written approval of SPORTON INTERNATIONAL (SHENZHEN) INC., the test report shall not be reproduced except in full.

Prepared by: Ken Chen / Manager

Approved by: Jones Tsai / Manager



SPORTON INTERNATIONAL (SHENZHEN) INC.

**1F & 2F, Building A, Morning Business Center, No. 4003 ShiGu Rd., Xili Town,
Nanshan District, Shenzhen, Guangdong, P. R. China**



TABLE OF CONTENTS

SUMMARY OF TEST RESULT 4

1 GENERAL DESCRIPTION 5

 1.1 Applicant 5

 1.2 Manufacturer 5

 1.3 Product Feature of Equipment Under Test 5

 1.4 Product Specification of Equipment Under Test 6

 1.5 Modification of EUT 6

 1.6 Testing Location 7

 1.7 Applicable Standards 7

2 TEST CONFIGURATION OF EQUIPMENT UNDER TEST 8

 2.1 Carrier Frequency Channel 8

 2.2 Test Mode 9

 2.3 Connection Diagram of Test System 11

 2.4 Support Unit used in test configuration and system 12

 2.5 EUT Operation Test Setup 12

 2.6 Measurement Results Explanation Example 12

3 TEST RESULT 13

 3.1 26dB & 99% Occupied Bandwidth Measurement 13

 3.2 Maximum Conducted Output Power Measurement 15

 3.3 Power Spectral Density Measurement 17

 3.4 Unwanted Radiated Emission Measurement 20

 3.5 AC Conducted Emission Measurement 25

 3.6 Frequency Stability Measurement 29

 3.7 Automatically Discontinue Transmission 30

 3.8 Antenna Requirements 31

4 LIST OF MEASURING EQUIPMENTS 32

5 UNCERTAINTY OF EVALUATION 33

APPENDIX A. CONDUCTED TEST RESULTS

APPENDIX B. RADIATED TEST RESULTS

APPENDIX C. DUTY CYCLE PLOTS

APPENDIX D. SETUP PHOTOGRAPHS



REVISION HISTORY

REPORT NO.	VERSION	DESCRIPTION	ISSUED DATE
FR670507D	Rev. 01	Initial issue of report	Aug. 16, 2016



SUMMARY OF TEST RESULT

Report Section	FCC Rule	IC Rule	Description	Limit	Result	Remark
3.1	2.1049 15.403(i)	RSS-247 Section 6	26dB & 99% Bandwidth	-	Pass	-
3.2	15.407(a)	RSS-247 Section 6	Maximum Conducted Output Power	FCC ≤24 dBm (depend on band) IC RSS-247 Section 6 Limit	Pass	-
3.3	15.407(a)	RSS-247 Section 6	Power Spectral Density	FCC ≤11 dBm (depend on band) IC RSS-247 Section 6 Limit	Pass	-
3.4	15.407(b)	RSS-247 Section 6	Unwanted Emissions	≤ -17, -27 dBm (depend on band)&15.209(a)	Pass	Under limit 1.9 dB at 5150.000 MHz
3.5	15.207	RSS-Gen 8.8	AC Conducted Emission	15.207(a)	Pass	Under limit 16.67 dB at 0.510 MHz
3.6	15.407(g)	-	Frequency Stability	Within Operation Band	Pass	-
3.7	15.407(c)	RSS-247 6.4(2)	Automatically Discontinue Transmission	Discontinue Transmission	Pass	-
3.8	15.203 & 15.407(a)	N/A	Antenna Requirement	N/A	Pass	-



1 General Description

1.1 Applicant

TCL Communication Ltd.

5F, C-Tower, No. 232, Liang Jing Road, ZhangJiang High-Tech Park, Pudong Area, Shanghai, 201203, P. R. China

1.2 Manufacturer

TCL Communication Ltd.

5F, C-Tower, No. 232, Liang Jing Road, ZhangJiang High-Tech Park, Pudong Area, Shanghai, 201203, P. R. China

1.3 Product Feature of Equipment Under Test

Product Feature	
Equipment	Tablet PC
Brand Name	alcatel
Model Name	9015B
Marketing Name	Alcatel POP™ 7 LTE
FCC ID	2ACCJB066
EUT supports Radios application	GPRS/EGPRS/WCDMA/HSPA/DC-HSDPA/ HSPA+(16QAM uplink is not supported)/LTE/ WLAN 2.4GHz 802.11b/g/n HT20 WLAN 5GHz 802.11a/n HT20/HT40 Bluetooth v3.0 + EDR/Bluetooth v4.1 LE
IMEI Code	Conducted: 014732000100067 Radiation: NA Conduction: 014732000100075
HW Version	Pixi4-7 4G TMO_MAIN_V03
SW Version	5RA2
EUT Stage	Production Unit

Remark: The above EUT's information was declared by manufacturer. Please refer to the specifications or user's manual for more detailed description.



1.4 Product Specification of Equipment Under Test

Standards-related Product Specification	
Tx/Rx Frequency Range	5180 MHz ~ 5240 MHz 5260 MHz ~ 5320 MHz
Maximum Output Power to Antenna	<5180 MHz ~ 5240 MHz> 802.11a : 14.97 dBm / 0.0314 W 802.11n HT20 : 15.15 dBm / 0.0327 W 802.11n HT40 : 14.39 dBm / 0.0275 W <5260 MHz ~ 5320 MHz> 802.11a : 14.66 dBm / 0.0292 W 802.11n HT20 : 14.74 dBm / 0.0298 W 802.11n HT40 : 13.67 dBm / 0.0233 W
99% Occupied Bandwidth	<5180 MHz ~ 5240 MHz> 802.11a : 25.17 MHz 802.11n HT20 : 29.22 MHz 802.11n HT40 : 47.85 MHz <5260 MHz ~ 5320 MHz> 802.11a : 24.23 MHz 802.11n HT20 : 25.32 MHz 802.11n HT40 : 43.06 MHz
Antenna Type	PIFA Antenna
Antenna Gain	<5180 MHz ~ 5240 MHz>: -3.00 dBi <5260 MHz ~ 5320 MHz>: -3.00 dBi
Type of Modulation	OFDM (BPSK / QPSK / 16QAM / 64QAM)

1.5 Modification of EUT

No modifications are made to the EUT during all test items.



1.6 Testing Location

Test Site	SPORTON INTERNATIONAL (SHENZHEN) INC.	
Test Site Location	1F & 2F, Building A, Morning Business Center, No. 4003 ShiGu Rd., Xili Town, Nanshan District, Shenzhen, Guangdong, P. R. China TEL: +86-755-8637-9589 FAX: +86-755-8637-9595	
Test Site No.	Sporton Site No.	
	TH01-SZ	CO01-SZ

Test Site	SPORTON INTERNATIONAL (SHENZHEN) INC.	
Test Site Location	No. 3 Building, the third floor of south, Shahe River west, Fengzeyuan warehouse, Nanshan District, Shenzhen, Guangdong, P. R. China TEL: +86-755- 3320-2398	
Test Site No.	Sporton Site No.	FCC/IC Registration No.
	03CH03-SZ	565805/4086F

Note: The test site complies with ANSI C63.4 2014 requirement.

1.7 Applicable Standards

According to the specifications of the manufacturer, the EUT must comply with the requirements of the following standards:

- ♦ FCC Part 15 Subpart E
- ♦ FCC KDB 789033 D02 General UNII Test Procedures New Rules v01r02
- ♦ ANSI C63.10-2013

Remark:

1. All test items were verified and recorded according to the standards and without any deviation during the test.
2. This EUT has also been tested and complied with the requirements of FCC Part 15, Subpart B, recorded in a separate test report.



2 Test Configuration of Equipment Under Test

The EUT has been associated with peripherals and configuration operated in a manner tended to maximize its emission characteristics in a typical application. Frequency range investigated: conducted emission (150 kHz to 30 MHz) and radiated emission (9 kHz to the 10th harmonic of the highest fundamental frequency or to 40 GHz, whichever is lower). For radiated measurement, pre-scanned in three orthogonal panels, X, Y, Z. The worst cases (X plane) were recorded in this report.

2.1 Carrier Frequency Channel

Frequency Band	Channel	Freq. (MHz)	Channel	Freq. (MHz)
5150-5250 MHz Band 1 (U-NII-1)	36	5180	44	5220
	38	5190	46	5230
	40	5200	48	5240

Frequency Band	Channel	Freq. (MHz)	Channel	Freq. (MHz)
5250-5350 MHz Band 2 (U-NII-2A)	52	5260	60	5300
	54	5270	62	5310
	56	5280	64	5320

Note: The above Frequency and Channel in boldface were 802.11n HT40.



2.2 Test Mode

Final test mode of conducted test items and radiated spurious emissions are considering the modulation and worse data rates as below table.

Modulation	Data Rate
802.11a	6 Mbps
802.11n HT20	MCS0
802.11n HT40	MCS0

AC Conducted Emission	Mode 1 : GPRS850 Idle + Bluetooth Link + WLAN (5GHz) Link + USB Cable (Charging from Adapter) + Earphone
Remark: 1. For Radiated TCs, the tests were performed with Adapter, Earphone and USB Cable.	



Ch. #		Band I : 5180-5240 MHz	Band II : 5260-5320 MHz
		802.11a	802.11a
L	Low	36	52
M	Middle	44	60
H	High	48	64

Ch. #		Band I : 5180-5240 MHz	Band II : 5260-5320 MHz
		802.11n HT20	802.11n HT20
L	Low	36	52
M	Middle	44	60
H	High	48	64

Ch. #		Band I : 5180-5240 MHz	Band II : 5260-5320 MHz
		802.11n HT40	802.11n HT40
L	Low	38	54
M	Middle	-	-
H	High	46	62

2.3 Connection Diagram of Test System

<WLAN Tx Mode>

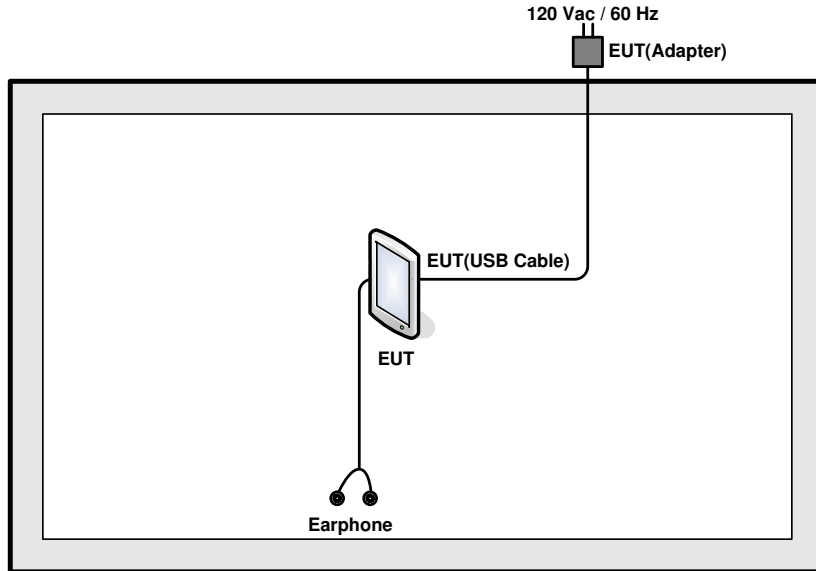

<AC Conducted Emission Mode>

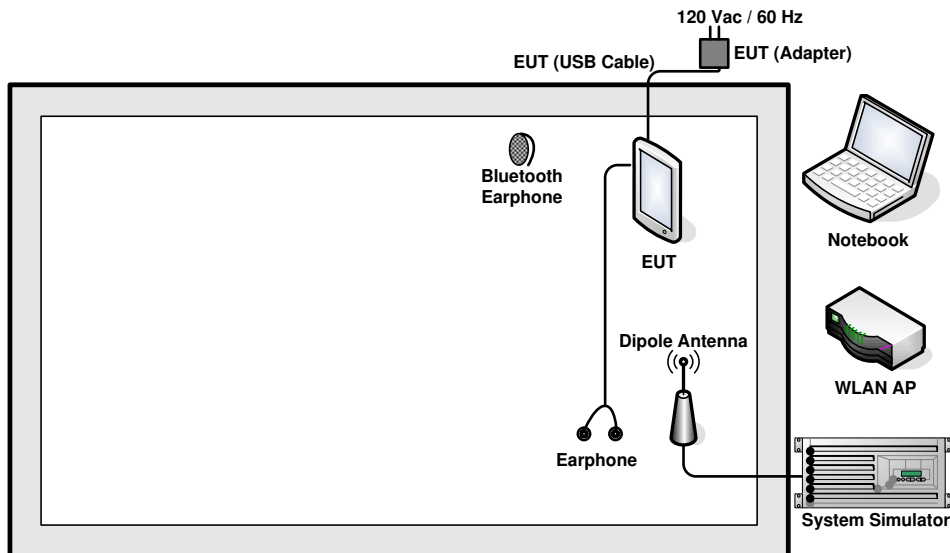

2.4 Support Unit used in test configuration and system

Item	Equipment	Trade Name	Model Name	FCC ID	Data Cable	Power Cord
1.	Notebook	Lenovo	E540	FCC DoC	N/A	AC I/P: Unshielded, 1.8 m DC O/P: Shielded, 1.8 m
2.	WLAN AP	D-Link	DIR-820L	KA2IR810LA1	N/A	Unshielded, 1.8 m
3.	System Simulator	Anritsu	MT8820C	N/A	N/A	Unshielded, 1.8 m
4.	Bluetooth Earphone	Nokia	BH-108	PYAHS-107W	N/A	N/A
5.	DC Power Supply	GW INSTEK	GPD-2303S	N/A	N/A	Unshielded, 1.8 m
6.	SD Card	SanDisk	4G class 4	FCC DoC	N/A	N/A
7.	Earphone	Apple	MC525 ZP/A	N/A	Shielded, 1.0m	N/A
8.	iPod Earphone	Apple	MC690 ZP/A	FCC DoC	Shielded, 1.6 m	N/A

2.5 EUT Operation Test Setup

For WLAN RF test items, an engineering test program was provided and enabled to make EUT continuously transmit/receive.

For AC power line conducted emissions, the EUT was set to connect with the Notebook under large package sizes transmission.

2.6 Measurement Results Explanation Example

For all conducted test items:

The offset level is set in the spectrum analyzer to compensate the RF cable loss and attenuator factor between EUT conducted output port and spectrum analyzer. With the offset compensation, the spectrum analyzer reading level is exactly the EUT RF output level.

Example :

The spectrum analyzer offset is derived from RF cable loss and attenuator factor.

Offset = RF cable loss + attenuator factor.

Following shows an offset computation example with cable loss 6.5 dB and 10dB attenuator.

$$\begin{aligned}
 \text{Offset(dB)} &= \text{RF cable loss(dB)} + \text{attenuator factor(dB)}. \\
 &= 6.5 + 10 = 16.5 \text{ (dB)}
 \end{aligned}$$

3 Test Result

3.1 26dB & 99% Occupied Bandwidth Measurement

3.1.1 Description of 26dB & 99% Occupied Bandwidth

This section is for reporting purpose only.

There is no restriction limits for bandwidth.

3.1.2 Measuring Instruments

The measuring equipment is listed in the section 4 of this test report.

3.1.3 Test Procedures

1. The testing follows FCC KDB 789033 D02 General UNII Test Procedures New Rules v01r02.
Section C) Emission bandwidth
2. Set RBW = approximately 1% of the emission bandwidth.
3. Set the VBW > RBW.
4. Detector = Peak.
5. Trace mode = max hold
6. Measure the maximum width of the emission that is 26 dB down from the peak of the emission.
Compare this with the RBW setting of the analyzer. Readjust RBW and repeat measurement as needed until the RBW/EBW ratio is approximately 1%.
7. For 99% Bandwidth Measurement, the spectrum analyzer's resolution bandwidth (RBW) is set 1MHz and set the Video bandwidth (VBW) $\geq 3 * RBW$.
8. Measure and record the results in the test report.

3.1.4 Test Setup

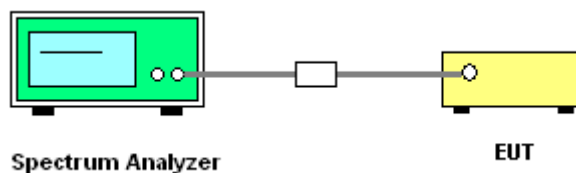



3.1.5 Test Result of 26dB & 99% Occupied Bandwidth Plots

Please refer to Appendix A.

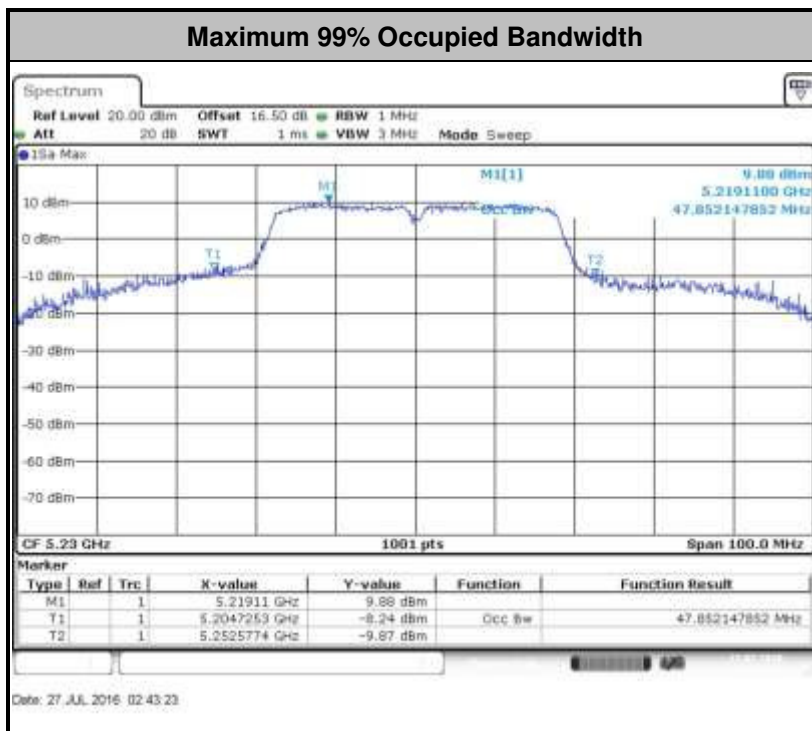
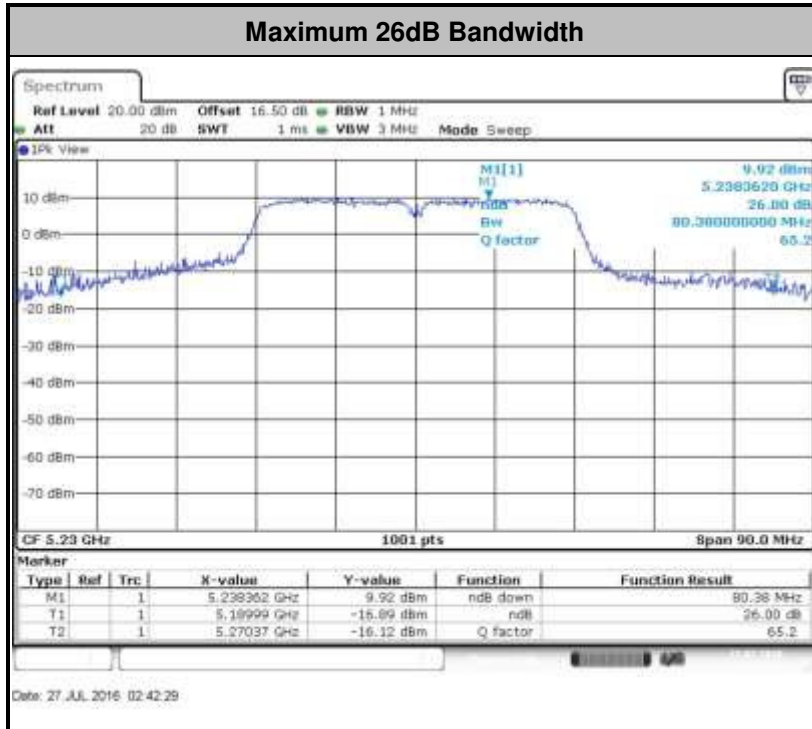



3.2 Maximum Conducted Output Power Measurement

3.2.1 Limit of Maximum Conducted Output Power

<FCC 14-30 CFR 15.407>

For mobile and portable client devices in the 5.15–5.25 GHz band, the maximum conducted output power over the frequency band of operation shall not exceed 250 mW.

For the 5.25–5.35 GHz, the maximum conducted output power over the frequency bands of operation shall not exceed the lesser of 250 mW or $11 \text{ dBm} + 10 \log B$, where B is the 26 dB emission bandwidth in megahertz.

If transmitting antennas of directional gain greater than 6 dBi are used, the peak output power shall be reduced by the amount in dB that the directional gain of the antenna exceeds 6 dBi.

Note that U-NII-2 band, devices with a maximum e.i.r.p. greater than 500 mW shall implement TPC in order to have the capability to operate at least 6 dB below the maximum permitted e.i.r.p. of 1 W.

3.2.2 Measuring Instruments

The measuring equipment is listed in the section 4 of this test report.

3.2.3 Test Procedures

The testing follows Method PM of FCC KDB 789033 D02 General UNII Test Procedures New Rules v01r02.

Method PM (Measurement using an RF average power meter):

1. Measurement is performed using a wideband RF power meter.
2. The EUT is configured to transmit continuously with a consistent duty cycle at its maximum power control level.
3. Measure the average power of the transmitter, and the average power is corrected with duty factor, $10 \log(1/x)$, where x is the duty cycle.

3.2.4 Test Setup

For normal channel:

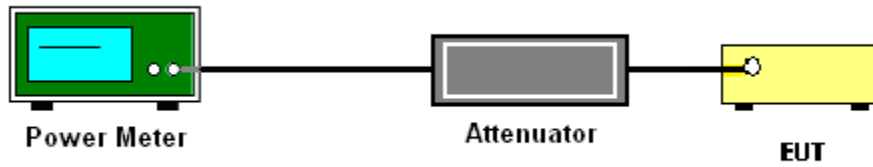

3.2.5 Test Result of Maximum Conducted Output Power

Please refer to Appendix A.



3.3 Power Spectral Density Measurement

3.3.1 Limit of Power Spectral Density

<FCC 14-30 CFR 15.407>

For mobile and portable client devices in the 5.15–5.25 GHz band, the maximum power spectral density shall not exceed 11dBm in any 1 megahertz band.

For the 5.25–5.35 GHz bands, the maximum power spectral density shall not exceed 11 dBm in any 1 megahertz band.

If transmitting antennas of directional gain greater than 6 dBi are used, the peak output power shall be reduced by the amount in dB that the directional gain of the antenna exceeds 6 dBi.

3.3.2 Measuring Instruments

The measuring equipment is listed in the section 4 of this test report.

3.3.3 Test Procedures

The testing follows FCC KDB 789033 D02 General UNII Test Procedures New Rules v01r02.
Section F) Maximum power spectral density.

Method SA-2

(trace averaging across on and off times of the EUT transmissions, followed by duty cycle correction).

1. The testing follows Method SA-2 of FCC KDB 789033 D02 General UNII Test Procedures New Rules v01r02.
 - Measure the duty cycle.
 - Set span to encompass the entire emission bandwidth (EBW) of the signal.
 - Set RBW = 1 MHz.
 - Set VBW \geq 3 MHz.
 - Number of points in sweep \geq 2 Span / RBW.
 - Sweep time = auto.
 - Detector = RMS
 - Trace average at least 100 traces in power averaging mode.
 - Add $10 \log(1/x)$, where x is the duty cycle, to the measured power in order to compute the average power during the actual transmission times. For example, add $10 \log(1/0.25) = 6$ dB if the duty cycle is 25 percent.
2. The RF output of EUT was connected to the spectrum analyzer by a low loss cable.
3. Each plot has already offset with cable loss, and attenuator loss. Measure the PPSD and record it.

3.3.4 Test Setup

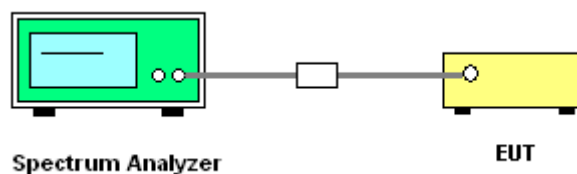



3.3.5 Test Result of Power Spectral Density

Please refer to Appendix A.



Note: Average Power Density (dB) = Measured value+ Duty Factor



3.4 Unwanted Radiated Emission Measurement

This section as specified in FCC Part 15.407(b) is to measure unwanted emissions through radiated measurement for band edge spurious emissions and out of band emissions measurement. The unwanted emissions shall comply with 15.407(b)(1) to (6), and restricted bands per FCC Part15.205.

3.4.1 Limit of Unwanted Emissions

(1) For transmitters operating in the 5150-5250 MHz band: all emissions outside of the 5150-5350 MHz band shall not exceed an EIRP of -27dBm/MHz.

For transmitters operating in the 5250-5350 MHz band: all emissions outside of the 5150-5350 MHz band shall not exceed an EIRP of -27 dBm/MHz. Devices operating in the 5250-5350 MHz band that generate emissions in the 5150-5250 MHz band must meet all applicable technical requirements for operation in the 5150-5250 MHz band (including indoor use) or alternatively meet an out-of-band emission EIRP limit of -27 dBm/MHz in the 5150-5250 MHz band.

(2) Unwanted spurious emissions fallen in restricted bands per FCC Part15.205 shall comply with the general field strength limits set forth in § 15.209 as below table,

Frequency (MHz)	Field Strength (microvolts/meter)	Measurement Distance (meters)
0.009 – 0.490	2400/F(kHz)	300
0.490 – 1.705	24000/F(kHz)	30
1.705 – 30.0	30	30
30 – 88	100	3
88 – 216	150	3
216 - 960	200	3
Above 960	500	3

Note: The following formula is used to convert the EIRP to field strength.

$$E = \frac{1000000\sqrt{30P}}{3} \mu\text{V/m, where P is the eirp (Watts)}$$

EIRP (dBm)	Field Strength at 3m (dBμV/m)
-17	78.3
- 27	68.3

(3) KDB789033 D01 v01r02 G)2)c) As specified in 15.407(b), emissions above 1000 MHz that are outside of the restricted bands are subject to a peak emission limit of -27 dBm/MHz (or -17 dBm/MHz as specified in 15.407(b)(4)). However, an out-of-band emission that complies with both the average and peak limits of 15.209 is not required to satisfy the -27 dBm/MHz or -17 dBm/MHz peak emission limit.



3.4.2 Measuring Instruments

The measuring equipment is listed in the section 4 of this test report.

3.4.3 Test Procedures

1. The testing follows FCC KDB 789033 D02 General UNII Test Procedures New Rules v01r02. Section G) Unwanted emissions measurement.

(1) Procedure for Unwanted Emissions Measurements Below 1000MHz

- RBW = 120 kHz
- VBW = 300 kHz
- Detector = Peak
- Trace mode = max hold

(2) Procedure for Peak Unwanted Emissions Measurements Above 1000 MHz

- RBW = 1 MHz
- VBW \geq 3 MHz
- Detector = Peak
- Sweep time = auto
- Trace mode = max hold

(3) Procedures for Average Unwanted Emissions Measurements Above 1000MHz

- RBW = 1 MHz
- VBW = 10 Hz, when duty cycle is no less than 98 percent.
- VBW \geq 1/T, when duty cycle is less than 98 percent where T is the minimum transmission duration over which the transmitter is on and is transmitting at its maximum power control level for the tested mode of operation.

2. The EUT was placed on a turntable with 0.8 meter for frequency below 1GHz and 1.5 meter for frequency above 1GHz respectively above ground.
3. The EUT was set 3 meters from the interference receiving antenna which was mounted on the top of a variable height antenna tower.
4. The antenna is a broadband antenna and its height is adjusted between one meter and four meters above ground to find the maximum value of the field strength for both horizontal polarization and vertical polarization of the antenna.
5. For each suspected emission, the EUT was arranged to its worst case and then adjust the antenna tower (from 1 m to 4 m) and turntable (from 0 degree to 360 degrees) to find the maximum reading.
6. For testing below 1GHz, if the emission level of the EUT in peak mode was 3 dB lower than the limit specified, then peak values of EUT will be reported, otherwise, the emissions will be repeated one by one using the CISPR quasi-peak method and reported.
7. For testing above 1GHz, the emission level of the EUT in peak mode was 20dB lower than average limit (that means the emission level in average mode also complies with the limit in average mode), then peak values of EUT will be reported, otherwise, the emissions will be measured in average mode again and reported.

3.4.4 Test Setup

For radiated emissions below 30MHz

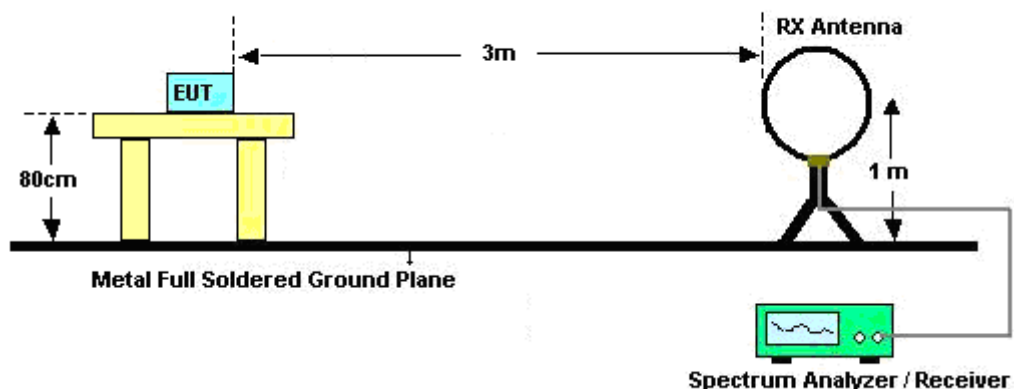

For radiated emissions from 30MHz to 1GHz

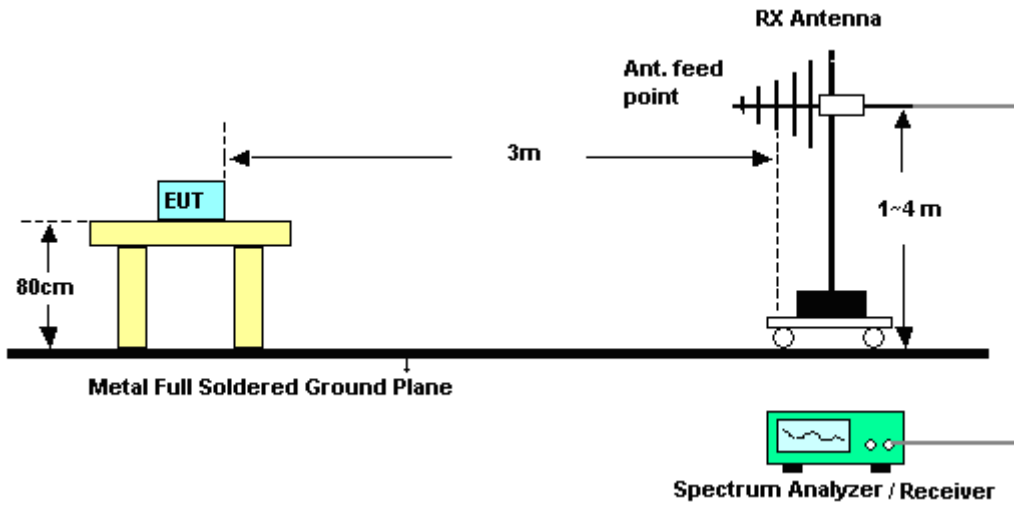

For radiated emissions above 1GHz

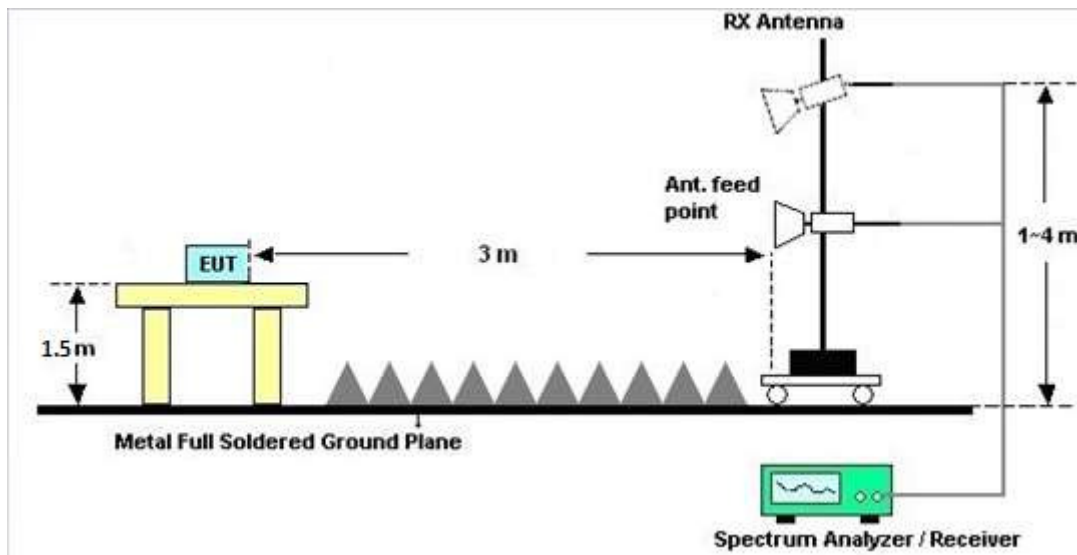

3.4.5 Test Results of Radiated Emissions (9 kHz ~ 30 MHz)

The low frequency, which started from 9 kHz to 30MHz, was pre-scanned and the result which was 20dB lower than the limit line per 15.31(o) was not reported.



3.4.6 Test Result of Radiated Band Edges

Please refer to Appendix B.

3.4.7 Duty Cycle

Please refer to Appendix C

3.4.8 Test Result of Unwanted Radiated Emission (30MHz ~ 10th Harmonic)

Please refer to Appendix B.



3.5 AC Conducted Emission Measurement

3.5.1 Limit of AC Conducted Emission

For equipment that is designed to be connected to the public utility (AC) power line, the radio frequency voltage that is conducted back onto the AC power line on any frequency or frequencies within the band 150 kHz to 30 MHz shall not exceed the limits in the following table.

Frequency of emission (MHz)	Conducted limit (dB μ V)	
	Quasi-peak	Average
0.15-0.5	66 to 56*	56 to 46*
0.5-5	56	46
5-30	60	50

*Decreases with the logarithm of the frequency.

3.5.2 Measuring Instruments

The measuring equipment is listed in the section 4 of this test report.

3.5.3 Test Procedures

1. The EUT was placed 0.4 meter from the conducting wall of the shielding room was kept at least 80 centimeters from any other grounded conducting surface.
2. Connect EUT to the power mains through a line impedance stabilization network (LISN).
3. All the support units are connecting to the other LISN.
4. The LISN provides 50 ohm coupling impedance for the measuring instrument.
5. The FCC states that a 50 ohm, 50 microhenry LISN should be used.
6. Both sides of AC line were checked for maximum conducted interference.
7. The frequency range from 150 kHz to 30 MHz was searched.
8. Set the test-receiver system to Peak Detect Function and specified bandwidth with Maximum Hold Mode.

3.5.4 Test Setup

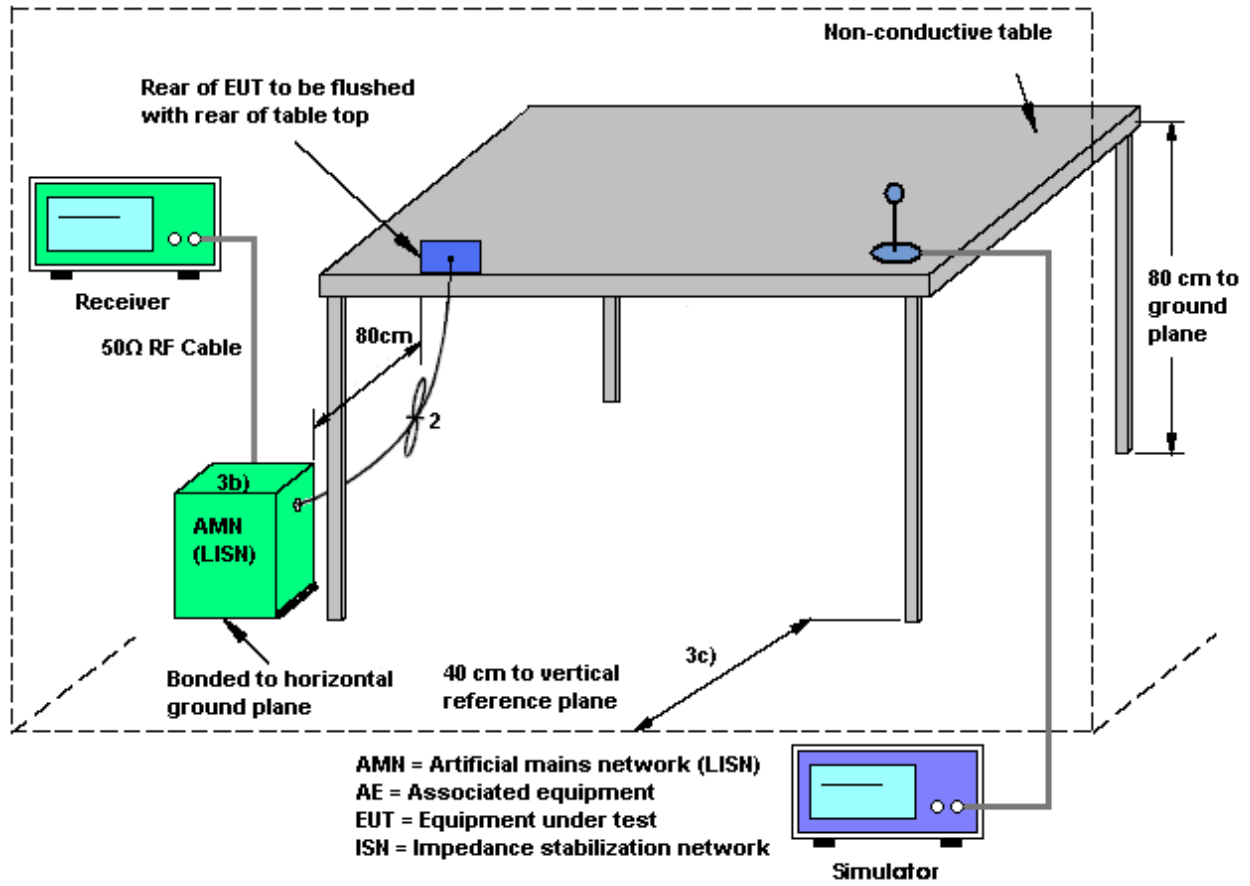



3.5.5 Test Result of AC Conducted Emission

Test Mode :	Mode 1	Temperature :	21~23°C
Test Engineer :	Tao Cheng	Relative Humidity :	41~43%
Test Voltage :	120Vac / 60Hz	Phase :	Line
Function Type :	GPRS850 Idle + Bluetooth Link + WLAN (5GHz) Link + USB Cable (Charging from Adapter) + Earphone		

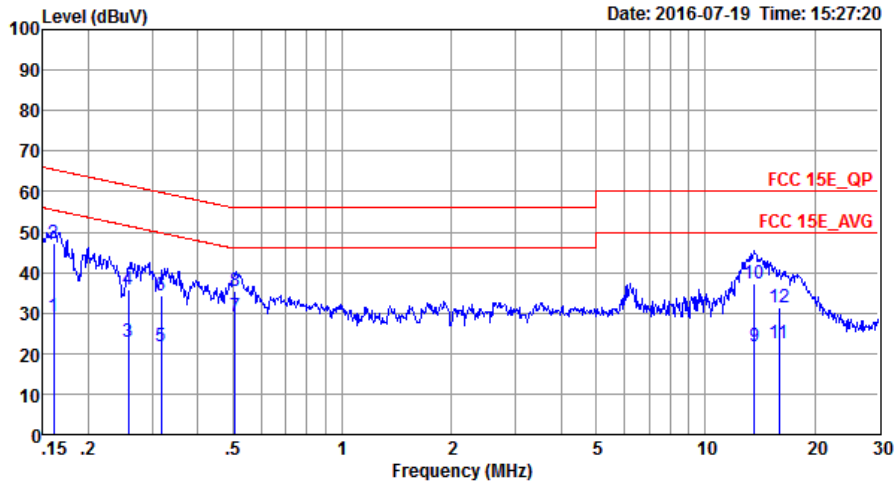

Site : C001-SZ
 Condition: FCC 15E_QP LISN_20160509 LINE

Mode : Mode 1
 IMEI : 014732000100075

	Freq	Level	Over Limit	Limit Line	Read Level	LISN Factor	Cable Loss	Remark
	MHz	dBuV	dB	dBuV	dBuV	dB	dB	
1	0.16	29.21	-26.22	55.43	18.50	0.13	10.58	Average
2	0.16	47.21	-18.22	65.43	36.50	0.13	10.58	QP
3	0.26	22.96	-28.55	51.51	12.40	0.11	10.45	Average
4	0.26	35.96	-25.55	61.51	25.40	0.11	10.45	QP
5	0.32	21.80	-28.00	49.80	11.30	0.11	10.39	Average
6	0.32	34.30	-25.50	59.80	23.80	0.11	10.39	QP
7 *	0.51	29.33	-16.67	46.00	19.00	0.11	10.22	Average
8	0.51	35.43	-20.57	56.00	25.10	0.11	10.22	QP
9	13.62	21.78	-28.22	50.00	11.10	0.29	10.39	Average
10	13.62	37.18	-22.82	60.00	26.50	0.29	10.39	QP
11	15.97	22.67	-27.33	50.00	11.90	0.31	10.46	Average
12	15.97	31.37	-28.63	60.00	20.60	0.31	10.46	QP



Test Mode :	Mode 1	Temperature :	21~23°C
Test Engineer :	Tao Cheng	Relative Humidity :	41~43%
Test Voltage :	120Vac / 60Hz	Phase :	Neutral
Function Type :	GPRS850 Idle + Bluetooth Link + WLAN (5GHz) Link + USB Cable (Charging from Adapter) + Earphone		

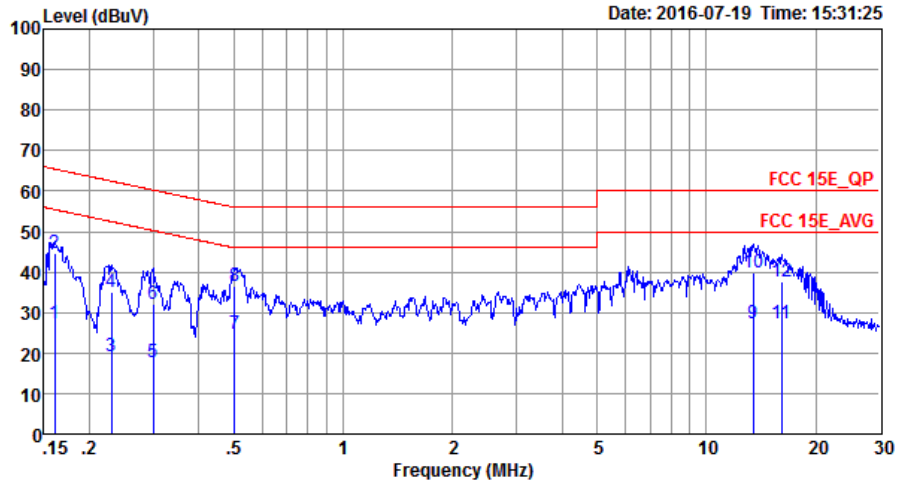

Site : CO01-SZ
 Condition: FCC 15E_QP LISN_20160509 NEUTRAL

Mode : Mode 1
 IMEI : 014732000100075

	Freq	Level	Over Limit	Limit Line	Read Level	LISN Factor	Cable Loss	Remark
	MHz	dBuV	dB	dBuV	dBuV	dB	dB	
1	0.16	27.31	-28.12	55.43	16.60	0.13	10.58	Average
2	0.16	44.61	-20.82	65.43	33.90	0.13	10.58	QP
3	0.23	19.08	-33.36	52.44	8.50	0.11	10.47	Average
4	0.23	34.98	-27.46	62.44	24.40	0.11	10.47	QP
5	0.30	17.63	-32.61	50.24	7.10	0.11	10.42	Average
6	0.30	32.13	-28.11	60.24	21.60	0.11	10.42	QP
7	0.50	24.83	-21.17	46.00	14.50	0.11	10.22	Average
8 *	0.50	36.53	-19.47	56.00	26.20	0.11	10.22	QP
9	13.48	27.48	-22.52	50.00	16.80	0.29	10.39	Average
10	13.48	39.78	-20.22	60.00	29.10	0.29	10.39	QP
11	16.14	27.38	-22.62	50.00	16.60	0.32	10.46	Average
12	16.14	37.68	-22.32	60.00	26.90	0.32	10.46	QP

3.6 Frequency Stability Measurement

3.6.1 Limit of Frequency Stability

Manufacturers of U-NII devices are responsible for ensuring frequency stability such that an emission is maintained within the band of operation under all conditions of normal operation as specified in the user's manual.

3.6.2 Measuring Instruments

The measuring equipment is listed in the section 4 of this test report.

3.6.3 Test Procedures

1. To ensure emission at the band edge is maintained within the authorized band, those values shall be measured by radiation emissions at upper and lower frequency points, and finally compensated by frequency deviation as procedures below.
2. The EUT was operated at the maximum output power, and connected to the spectrum analyzer, which is set to maximum hold function and peak detector. The peak value of the power envelope was measured and noted. The upper and lower frequency points were respectively measured relatively 10dB lower than the measured peak value.
3. The frequency deviation was calculated by adding the upper frequency point and the lower frequency point divided by two. Those detailed values of frequency deviation are provided in table below.

3.6.4 Test Setup

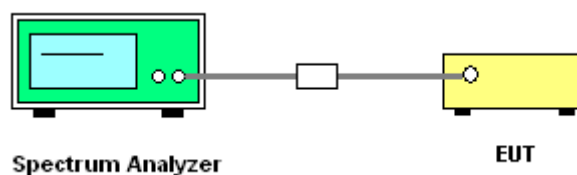

3.6.5 Test Result of Frequency Stability

Please refer to Appendix A.



3.7 Automatically Discontinue Transmission

3.7.1 Limit of Automatically Discontinue Transmission

The device shall automatically discontinue transmission in case of either absence of information to transmit or operational failure. These provisions are not intended to preclude the transmission of control or signaling information or the use of repetitive codes used by certain digital technologies to complete frame or burst intervals. Applicants shall include in their application for equipment authorization to describe how this requirement is met.

3.7.2 Measuring Instruments

The measuring equipment is listed in the section 4 of this test report.

3.7.3 Test Result of Automatically Discontinue Transmission

While the EUT is not transmitting any information, the EUT can automatically discontinue transmission and become standby mode for power saving. The EUT can detect the controlling signal of ACK message transmitting from remote device and verify whether it shall resend or discontinue transmission.



3.8 Antenna Requirements

3.8.1 Standard Applicable

According to FCC 47 CFR Section 15.407(a)(1)(2), if transmitting antenna directional gain is greater than 6 dBi, both the peak transmit power and the peak power spectral density shall be reduced by the amount in dB that the directional gain of the antenna exceeds 6 dBi.

3.8.2 Antenna Anti-Replacement Construction

An embedded-in antenna design is used.

3.8.3 Antenna Gain

The antenna gain is less than 6 dBi. Therefore, it is not necessary to reduce maximum peak output power limit.



4 List of Measuring Equipments

Instrument	Manufacturer	Model No.	Serial No.	Characteristics	Calibration Date	Test Date	Due Date	Remark
Spectrum Analyzer	R&S	FSV40	101078	9kHz~40GHz	May 07, 2016	Jul. 27, 2016	May 06, 2017	Conducted (TH01-SZ)
Pulse Power Sensor	Anritsu	MA2411B	1207253	30MHz~40GHz	Jan. 12, 2016	Jul. 27, 2016	Jan. 11, 2017	Conducted (TH01-SZ)
Power Meter	Anritsu	ML2495A	1218010	50MHz Bandwidth	Jan. 12, 2016	Jul. 27, 2016	Jan. 11, 2017	Conducted (TH01-SZ)
Thermal Chamber	Ten Billion Hongzhangroup	LP-150U	H2014081803	-40~+150°C	Jul. 16, 2016	Jul. 27, 2016	Jul. 15, 2017	Conducted (TH01-SZ)
EMI Test Receiver&SA	KEYSIGHT	N9038A	MY54450083	20Hz~8.4GHz	May 07, 2016	Jul. 14, 2016~ Aug. 02, 2016	May 06, 2017	Radiation (03CH03-SZ)
EXA Spectrum Analyzer	KEYSIGHT	N9010A	MY55150246	10Hz~44GHz;	May 07, 2016	Jul. 14, 2016~ Aug. 02, 2016	May 06, 2017	Radiation (03CH03-SZ)
Loop Antenna	R&S	HFH2-Z2	100354	9kHz~30MHz	May 07, 2016	Jul. 14, 2016~ Aug. 02, 2016	May 06, 2017	Radiation (03CH03-SZ)
Bilog Antenna	TeseQ	CBL6112D	35408	30MHz~2GHz	May 21, 2016	Jul. 14, 2016~ Aug. 02, 2016	May 20, 2017	Radiation (03CH03-SZ)
Double Ridge Horn Antenna	SCHWARZBECK	BBHA9120D	9120D-1355	1GHz~18GHz	May 07, 2016	Jul. 14, 2016~ Aug. 02, 2016	May 06, 2017	Radiation (03CH03-SZ)
SHF-EHF Horn	com-power	AH-840	101071	18GHz~40GHz	Aug. 19, 2015	Jul. 14, 2016~ Aug. 02, 2016	Aug. 18, 2016	Radiation (03CH03-SZ)
Amplifier	PREAMPLIFIER	BPA-530	102210	0.01Hz~3000MHz	Oct. 20, 2015	Jul. 14, 2016~ Aug. 02, 2016	Oct. 19, 2016	Radiation (03CH03-SZ)
Amplifier	Agilent Technologies	83017A	MY39501302	500MHz~26.5GHz	Jan. 12, 2016	Jul. 14, 2016~ Aug. 02, 2016	Jan. 11, 2017	Radiation (03CH03-SZ)
HF Amplifier	MITEQ	AMF-7D-00101800-30-10P-R	1943528	1GHz~18GHz	Oct. 20, 2015	Jul. 14, 2016~ Aug. 02, 2016	Oct. 19, 2016	Radiation (03CH03-SZ)
AC Power Source	Chroma	61601	616010001985	N/A	NCR	Jul. 14, 2016~ Aug. 02, 2016	NCR	Radiation (03CH03-SZ)
Turn Table	EM	EM1000	N/A	0~360 degree	NCR	Jul. 14, 2016~ Aug. 02, 2016	NCR	Radiation (03CH03-SZ)
Antenna Mast	EM	EM1000	N/A	1 m~4 m	NCR	Jul. 14, 2016~ Aug. 02, 2016	NCR	Radiation (03CH03-SZ)
EMI Receiver	R&S	ESC17	100724	9kHz~3GHz;	Nov. 23, 2015	Jul. 19, 2016	Nov. 22, 2016	Conduction (CO01-SZ)
AC LISN	EMCO	3816/2SH	00103892	9kHz~30MHz	Jan. 12, 2016	Jul. 19, 2016	Jan. 11, 2017	Conduction (CO01-SZ)
AC LISN (for auxiliary equipment)	MessTec	3816/2SH	00103912	9kHz~30MHz	Jan. 12, 2016	Jul. 19, 2016	Jan. 11, 2017	Conduction (CO01-SZ)
AC Power Source	Chroma	61602	616020000891	100Vac~250Vac	Jul. 16, 2016	Jul. 19, 2016	Jul. 15, 2017	Conduction (CO01-SZ)

NCR: No Calibration Required



5 Uncertainty of Evaluation

Uncertainty of Conducted Emission Measurement (150kHz ~ 30MHz)

Measuring Uncertainty for a Level of Confidence of 95% ($U = 2Uc(y)$)	2.3dB
-------------------------------------------------------------------------	-------

Uncertainty of Radiated Emission Measurement (30 MHz ~ 1000 MHz)

Measuring Uncertainty for a Level of Confidence of 95% ($U = 2Uc(y)$)	5.1 dB
-------------------------------------------------------------------------	--------

Uncertainty of Radiated Emission Measurement (1GHz ~ 18GHz)

Measuring Uncertainty for a Level of Confidence of 95% ($U = 2Uc(y)$)	5.0dB
-------------------------------------------------------------------------	-------

Uncertainty of Radiated Emission Measurement (18GHz ~ 40GHz)

Measuring Uncertainty for a Level of Confidence of 95% ($U = 2Uc(y)$)	5.0dB
-------------------------------------------------------------------------	-------



Appendix A. Conducted Test Results

Test Engineer:	Bruce Huang	Temperature:	24~26	°C
Test Date:	2016/7/27	Relative Humidity:	50~53	%

TEST RESULTS DATA
26dB and 99% OBW

Band I										
Mod.	Data Rate	NTX	CH.	Freq. (MHz)	99% Bandwidth (MHz)	26 dB Bandwidth (MHz)	IC 99% Bandwidth Power Limit (dBm)	IC 99% Bandwidth EIRP Limit (dBm)		
11a	6Mbps	1	36	5180	24.43	41.36	-	23.01		
11a	6Mbps	1	44	5220	25.17	41.71	-	23.01		
11a	6Mbps	1	48	5240	23.28	41.36	-	23.01		
HT20	MCS0	1	36	5180	26.12	43.21	-	23.01		
HT20	MCS0	1	44	5220	29.22	44.11	-	23.01		
HT20	MCS0	1	48	5240	24.88	43.91	-	23.01		
HT40	MCS0	1	38	5190	45.35	78.67	-	23.01		
HT40	MCS0	1	46	5230	47.85	80.38	-	23.01		

TEST RESULTS DATA
Average Power Table

FCC Band I										
Mod.	Data Rate	NTX	CH.	Freq. (MHz)	Duty Factor (dB)	Average Conducted Power (dBm)	FCC Conducted Power Limit (dBm)	DG (dBi)		Pass/Fail
11a	6Mbps	1	36	5180	0.58	14.43	24.00	-3.00		Pass
11a	6Mbps	1	44	5220	0.58	14.84	24.00	-3.00		Pass
11a	6Mbps	1	48	5240	0.58	14.97	24.00	-3.00		Pass
HT20	MCS0	1	36	5180	0.62	13.85	24.00	-3.00		Pass
HT20	MCS0	1	44	5220	0.62	15.15	24.00	-3.00		Pass
HT20	MCS0	1	48	5240	0.62	15.04	24.00	-3.00		Pass
HT40	MCS0	1	38	5190	1.18	10.39	24.00	-3.00		Pass
HT40	MCS0	1	46	5230	1.18	14.39	24.00	-3.00		Pass

TEST RESULTS DATA
Power Spectral Density

FCC Band I										
Mod.	Data Rate	N _{TX}	CH.	Freq. (MHz)	Duty Factor (dB)	Average Power Density (dBm/MHz)	Average PSD Limit (dBm/MHz)	DG (dBi)	-	Pass/Fail
11a	6Mbps	1	36	5180	0.58	4.55	11.00	-3.00		Pass
11a	6Mbps	1	44	5220	0.58	3.79	11.00	-3.00		Pass
11a	6Mbps	1	48	5240	0.58	3.85	11.00	-3.00		Pass
HT20	MCS0	1	36	5180	0.62	4.21	11.00	-3.00		Pass
HT20	MCS0	1	44	5220	0.62	3.74	11.00	-3.00		Pass
HT20	MCS0	1	48	5240	0.62	3.70	11.00	-3.00		Pass
HT40	MCS0	1	38	5190	1.18	1.43	11.00	-3.00		Pass
HT40	MCS0	1	46	5230	1.18	1.76	11.00	-3.00		Pass

TEST RESULTS DATA
26dB and 99% OBW

Band II										
Mod.	Data Rate	N _{TX}	CH.	Freq. (MHz)	99% Bandwidth (MHz)	26 dB Bandwidth (MHz)	IC 99% Bandwidth Power Limit (dBm)	IC 99% Bandwidth EIRP Limit (dBm)	FCC 26dB Bandwidth Power Limit (dBm)	Note
11a	6M bps	1	52	5260	24.23	41.76	23.98	30.00	23.98	
11a	6M bps	1	60	5300	21.83	37.81	23.98	30.00	23.98	
11a	6M bps	1	64	5320	22.33	33.32	23.98	30.00	23.98	
HT20	MCS 0	1	52	5260	24.38	44.26	23.98	30.00	23.98	
HT20	MCS 0	1	60	5300	23.63	40.76	23.98	30.00	23.98	
HT20	MCS 0	1	64	5320	25.32	41.61	23.98	30.00	23.98	
HT40	MCS 0	1	54	5270	43.06	67.52	23.98	30.00	23.98	
HT40	MCS 0	1	62	5310	38.36	51.79	23.98	30.00	23.98	

TEST RESULTS DATA
Average Power Table

FCC Band II										
Mod.	Data Rate	N _{TX}	CH.	Freq. (MHz)	Duty Factor (dB)	Average Conducted Power (dBm)	FCC Conducted Power Limit (dBm)	DG (dBi)	EIRP Power Limit (dBm)	Pass/Fail
11a	6M bps	1	52	5260	0.58	14.66	23.98	-3.00	26.99	Pass
11a	6M bps	1	60	5300	0.58	14.28	23.98	-3.00	26.99	Pass
11a	6M bps	1	64	5320	0.58	13.26	23.98	-3.00	26.99	Pass
HT20	MCS 0	1	52	5260	0.62	14.74	23.98	-3.00	26.99	Pass
HT20	MCS 0	1	60	5300	0.62	14.41	23.98	-3.00	26.99	Pass
HT20	MCS 0	1	64	5320	0.62	13.40	23.98	-3.00	26.99	Pass
HT40	MCS 0	1	54	5270	1.18	13.67	23.98	-3.00	26.99	Pass
HT40	MCS 0	1	62	5310	1.18	8.89	23.98	-3.00	26.99	Pass

TEST RESULTS DATA
Power Spectral Density

Band II										
Mod.	Data Rate	N _{TX}	CH.	Freq. (MHz)	Duty Factor (dB)	Average Power Density (dBm/MHz)	Average PSD Limit (dBm/MHz)	DG (dBi)		Pass/Fail
11a	6M bps	1	52	5260	0.58	3.86	11.00	-3.00		Pass
11a	6M bps	1	60	5300	0.58	3.23	11.00	-3.00		Pass
11a	6M bps	1	64	5320	0.58	3.24	11.00	-3.00		Pass
HT20	MCS 0	1	52	5260	0.62	3.64	11.00	-3.00		Pass
HT20	MCS 0	1	60	5300	0.62	2.75	11.00	-3.00		Pass
HT20	MCS 0	1	64	5320	0.62	2.95	11.00	-3.00		Pass
HT40	MCS 0	1	54	5270	1.18	0.95	11.00	-3.00		Pass
HT40	MCS 0	1	62	5310	1.18	-0.56	11.00	-3.00		Pass

TEST RESULTS DATA
Frequency Stability

Band I										
Mod.	Data Rate	NTX	CH.	Freq. (MHz)	Center Frequency (MHz)	Frequency Deviation (MHz)	Frequency Stability (ppm)	Temperature (°C)	Voltage (V)	Note
11a	6Mbps	1	36	5180	5180.075	0.075	14.48	20	3.6	
11a	6Mbps	1	36	5180	5180.075	0.075	14.48	20	4.2	
11a	6Mbps	1	36	5180	5180.075	0.075	14.48	20	3.9	
11a	6Mbps	1	36	5180	5180.075	0.075	14.48	-30	3.9	
11a	6Mbps	1	36	5180	5179.867	-0.133	-25.68	50	3.9	

Band II										
Mod.	Data Rate	NTX	CH.	Freq. (MHz)	Center Frequency (MHz)	Frequency Deviation (MHz)	Frequency Stability (ppm)	Temperature (°C)	Voltage (V)	Note
11a	6Mbps	1	64	5320	5320.050	0.050	9.40	20	3.6	
11a	6Mbps	1	64	5320	5320.050	0.050	9.40	20	4.2	
11a	6Mbps	1	64	5320	5320.050	0.050	9.40	20	3.9	
11a	6Mbps	1	64	5320	5320.050	0.050	9.40	-30	3.9	
11a	6Mbps	1	64	5320	5320.050	0.050	9.40	50	3.9	



Appendix B. Radiated Spurious Emission

Band 1 - 5150~5250MHz WIFI 802.11a (Band Edge @ 3m)

WIFI	Note	Frequency	Level	Over	Limit	Read	Antenna	Cable	Preamp	Ant	Table	Peak	Pol.
Ant.				Limit	Line	Level	Factor	Loss	Factor	Pos	Pos	Avg.	
1		(MHz)	(dBμV/m)	(dB)	(dBμV/m)	(dBμV)	(dB/m)	(dB)	(dB)	(cm)	(deg)	(P/A)	(H/V)
802.11a CH 36 5180MHz		5141.7	62.66	-11.34	74	56.16	32.93	7.26	33.69	158	196	P	H
		5150	52.1	-1.9	54	45.58	32.93	7.26	33.67	158	196	A	H
	*	5180	104.45	-	-	97.79	32.94	7.37	33.65	158	196	P	H
	*	5180	97.23	-	-	90.57	32.94	7.37	33.65	158	196	A	H
		5148.98	62.1	-11.9	74	55.58	32.93	7.26	33.67	245	22	P	V
		5149.5	48.32	-5.68	54	41.8	32.93	7.26	33.67	245	22	A	V
	*	5180	100.5	-	-	93.84	32.94	7.37	33.65	245	22	P	V
	*	5180	93.18	-	-	86.52	32.94	7.37	33.65	245	22	A	V
802.11a CH 44 5220MHz		5035.36	49.09	-24.91	74	42.78	32.91	7.15	33.75	150	202	P	H
		5150	39.39	-14.61	54	32.87	32.93	7.26	33.67	150	202	A	H
	*	5220	105.72	-	-	99.05	32.94	7.37	33.64	150	202	P	H
	*	5220	98.35	-	-	91.68	32.94	7.37	33.64	150	202	A	H
		5413.68	47.06	-26.94	74	40.15	32.98	7.43	33.5	150	202	P	H
		5414.4	39.28	-14.72	54	32.37	32.98	7.43	33.5	150	202	A	H
		5078.52	48.45	-25.55	74	42.1	32.92	7.15	33.72	242	12	P	V
		5031.2	39.13	-14.87	54	32.82	32.91	7.15	33.75	242	12	A	V
	*	5220	100.99	-	-	94.32	32.94	7.37	33.64	242	12	P	V
	*	5220	93.75	-	-	87.08	32.94	7.37	33.64	242	12	A	V
		5406.72	47.02	-26.98	74	40.11	32.98	7.43	33.5	242	12	P	V
		5404.8	38.25	-15.75	54	31.38	32.98	7.39	33.5	242	12	A	V



802.11a CH 48 5240MHz		5004.68	48.16	-25.84	74	41.89	32.9	7.14	33.77	154	215	P	H
		5055.38	39.22	-14.78	54	32.9	32.91	7.15	33.74	154	215	A	H
	*	5240	106.37	-	-	99.67	32.95	7.37	33.62	154	215	P	H
	*	5240	99.11	-	-	92.41	32.95	7.37	33.62	154	215	A	H
		5434.08	48.39	-25.61	74	41.45	32.99	7.43	33.48	154	215	P	H
		5425.92	40.3	-13.7	54	33.37	32.98	7.43	33.48	154	215	A	H
		5045.24	48.82	-25.18	74	42.5	32.91	7.15	33.74	250	21	P	V
		5042.12	39.12	-14.88	54	32.8	32.91	7.15	33.74	250	21	A	V
	*	5240	102.15	-	-	95.45	32.95	7.37	33.62	250	21	P	V
	*	5240	95.46	-	-	88.76	32.95	7.37	33.62	250	21	A	V
		5425.2	46.88	-27.12	74	39.95	32.98	7.43	33.48	250	21	P	V
		5436.48	38.76	-15.24	54	31.82	32.99	7.43	33.48	250	21	A	V
Remark	1. No other spurious found. 2. All results are PASS against Peak and Average limit line.												



Band 1 5150~5250MHz
WIFI 802.11a (Harmonic @ 3m)

WIFI Ant. 1	Note	Frequency (MHz)	Level (dBμV/m)	Over Limit (dB)	Limit Line (dBμV/m)	Read Level (dBμV)	Antenna Factor (dB/m)	Cable Loss (dB)	Preamp Factor (dB)	Ant Pos (cm)	Table Pos (deg)	Peak Avg. (P/A)	Pol. (H/V)
802.11a		10360	50.16	-23.84	74	60.47	38.62	10.07	59	250	0	P	H
CH 36		10360	49.35	-24.65	74	59.66	38.62	10.07	59	250	0	P	V
5180MHz													
802.11a		10440	50.29	-23.71	74	58.88	39.85	10.58	59.02	150	0	P	H
CH 44		10440	50.07	-23.93	74	58.66	39.85	10.58	59.02	250	0	P	V
5220MHz													
802.11a		10480	48.15	-25.85	74	58.24	38.79	10.15	59.03	250	0	P	H
CH 48		10480	49.53	-24.47	74	59.62	38.79	10.15	59.03	250	0	P	V
5240MHz													
Remark	1. No other spurious found. 2. All results are PASS against Peak and Average limit line.												



Band 1 5150~5250MHz
WIFI 802.11n HT20 (Band Edge @ 3m)

WIFI Ant. 1	Note	Frequency (MHz)	Level (dBμV/m)	Over Limit (dB)	Limit Line (dBμV/m)	Read Level (dBμV)	Antenna Factor (dB/m)	Cable Loss (dB)	Preamp Factor (dB)	Ant Pos (cm)	Table Pos (deg)	Peak Avg. (P/A)	Pol. (H/V)
802.11n HT20 CH 36 5180MHz		5148.46	65.04	-8.96	74	58.52	32.93	7.26	33.67	153	337	P	H
		5149.76	50.62	-3.38	54	44.1	32.93	7.26	33.67	153	337	A	H
	*	5180	102.53	-	-	95.87	32.94	7.37	33.65	153	337	P	H
	*	5180	94.95	-	-	88.29	32.94	7.37	33.65	153	337	A	H
		5150	59.68	-14.32	74	53.16	32.93	7.26	33.67	250	76	P	V
		5150	49.22	-4.78	54	42.7	32.93	7.26	33.67	250	76	A	V
	*	5180	101.2	-	-	94.54	32.94	7.37	33.65	250	76	P	V
		5180	93.49	-	-	86.83	32.94	7.37	33.65	250	76	A	V
802.11n HT20 CH 44 5220MHz		5149.5	50.88	-23.12	74	44.36	32.93	7.26	33.67	150	213	P	H
		5149.5	39.12	-14.88	54	32.6	32.93	7.26	33.67	150	213	A	H
	*	5220	104.3	-	-	97.63	32.94	7.37	33.64	150	213	P	H
	*	5220	96.87	-	-	90.2	32.94	7.37	33.64	150	213	A	H
		5408.64	47.27	-26.73	74	40.36	32.98	7.43	33.5	150	213	P	H
		5407.2	39.26	-14.74	54	32.35	32.98	7.43	33.5	150	213	A	H
		5147.16	48.63	-25.37	74	42.11	32.93	7.26	33.67	250	360	P	V
		5031.98	39.24	-14.76	54	32.93	32.91	7.15	33.75	250	360	A	V
	*	5220	100.71	-	-	94.04	32.94	7.37	33.64	250	360	P	V
	*	5220	93.08	-	-	86.41	32.94	7.37	33.64	250	360	A	V
		5454.24	47.06	-26.94	74	40.07	32.99	7.47	33.47	250	360	P	V
	5416.08	38.44	-15.56	54	31.53	32.98	7.43	33.5	250	360	A	V	



802.11n HT20 CH 48 5240MHz		5135.46	47.7	-26.3	74	41.2	32.93	7.26	33.69	176	214	P	H
		5051.74	39.08	-14.92	54	32.76	32.91	7.15	33.74	176	214	A	H
	*	5240	105.56	-	-	98.86	32.95	7.37	33.62	176	214	P	H
	*	5240	98.38	-	-	91.68	32.95	7.37	33.62	176	214	A	H
		5431.2	49.72	-24.28	74	42.78	32.99	7.43	33.48	176	214	P	H
		5427.12	39.4	-14.6	54	32.47	32.98	7.43	33.48	176	214	A	H
		5042.38	47.97	-26.03	74	41.65	32.91	7.15	33.74	250	19	P	V
		5040.56	39.16	-14.84	54	32.85	32.91	7.15	33.75	250	19	A	V
	*	5240	101.71	-	-	95.01	32.95	7.37	33.62	250	19	P	V
	*	5240	93.65	-	-	86.95	32.95	7.37	33.62	250	19	A	V
		5385.36	46.69	-27.31	74	39.84	32.98	7.39	33.52	250	19	P	V
		5438.64	38.95	-15.05	54	32.01	32.99	7.43	33.48	250	19	A	V
Remark	<p>1. No other spurious found.</p> <p>2. All results are PASS against Peak and Average limit line.</p>												



Band 1 5150~5250MHz
WIFI 802.11n HT20 (Harmonic @ 3m)

WIFI Ant. 1	Note	Frequency (MHz)	Level (dBμV/m)	Over Limit (dB)	Limit Line (dBμV/m)	Read Level (dBμV)	Antenna Factor (dB/m)	Cable Loss (dB)	Preamp Factor (dB)	Ant Pos (cm)	Table Pos (deg)	Peak Avg. (P/A)	Pol. (H/V)
802.11n HT20 CH 36		10360	48.54	-25.46	74	58.85	38.62	10.07	59	250	0	P	H
5180MHz		10360	49.86	-24.14	74	60.17	38.62	10.07	59	250	0	P	V
802.11n HT20 CH 44		10440	49.75	-24.25	74	59.92	38.72	10.13	59.02	250	0	P	H
5220MHz		10440	48.56	-25.44	74	58.73	38.72	10.13	59.02	250	0	P	V
802.11n HT20 CH 48		10480	47.89	-26.11	74	57.98	38.79	10.15	59.03	250	0	P	H
5240MHz		10480	48.02	-25.98	74	58.11	38.79	10.15	59.03	250	0	P	V
Remark	1. No other spurious found. 2. All results are PASS against Peak and Average limit line.												



Band 1 5150~5250MHz
WIFI 802.11n HT40 (Band Edge @ 3m)

WIFI Ant. 1	Note	Frequency (MHz)	Level (dBμV/m)	Over Limit (dB)	Limit Line (dBμV/m)	Read Level (dBμV)	Antenna Factor (dB/m)	Cable Loss (dB)	Preamp Factor (dB)	Ant Pos (cm)	Table Pos (deg)	Peak Avg. (P/A)	Pol. (H/V)	
802.11n HT40 CH 38 5190MHz		5149.5	57.26	-16.74	74	50.74	32.93	7.26	33.67	150	194	P	H	
		5150	48.16	-5.84	54	41.64	32.93	7.26	33.67	150	194	A	H	
	*	5190	96.11	-	-	89.45	32.94	7.37	33.65	150	194	P	H	
	*	5190	89.56	-	-	82.9	32.94	7.37	33.65	150	194	A	H	
		5420.4	47.04	-26.96	74	40.13	32.98	7.43	33.5	150	194	P	H	
		5460	39.4	-14.6	54	32.41	32.99	7.47	33.47	150	194	A	H	
		5149.24	57.76	-16.24	74	51.24	32.93	7.26	33.67	242	19	P	V	
		5149.5	46.26	-7.74	54	39.74	32.93	7.26	33.67	242	19	A	V	
	*	5190	93.42	-	-	86.76	32.94	7.37	33.65	242	19	P	V	
	*	5190	86.83	-	-	80.17	32.94	7.37	33.65	242	19	A	V	
		5445.6	46.6	-27.4	74	39.66	32.99	7.43	33.48	242	19	P	V	
		5442.72	38.7	-15.3	54	31.76	32.99	7.43	33.48	242	19	A	V	
	802.11n HT40 CH 46 5230MHz		5149.24	53.74	-20.26	74	47.22	32.93	7.26	33.67	180	360	P	H
			5150.00	46.43	-7.57	54	39.91	32.93	7.26	33.67	180	360	A	H
*		5230	101.73			95.03	32.95	7.37	33.62	180	360	P	H	
*		5230	94.35			87.65	32.95	7.37	33.62	180	360	A	H	
		5350.08	50.43	-23.57	74	43.6	32.97	7.39	33.53	180	360	P	H	
		5351.52	40.81	-13.19	54	33.98	32.97	7.39	33.53	180	360	A	H	
		5130.52	49.24	-24.76	74	42.74	32.93	7.26	33.69	250	175	P	V	
		5149.5	41.55	-12.45	54	35.03	32.93	7.26	33.67	250	175	A	V	
*		5230	94.17			87.47	32.95	7.37	33.62	250	175	P	V	
*		5230	84.7			78	32.95	7.37	33.62	250	175	A	V	
	5442.48	47.22	-26.78	74	40.28	32.99	7.43	33.48	250	175	P	V		
	5352.24	38.72	-15.28	54	31.89	32.97	7.39	33.53	250	175	A	V		
Remark	1. No other spurious found. 2. All results are PASS against Peak and Average limit line.													



Band 1 5150~5250MHz
WIFI 802.11n HT40 (Harmonic @ 3m)

WIFI Ant. 1	Note	Frequency (MHz)	Level (dBμV/m)	Over Limit (dB)	Limit Line (dBμV/m)	Read Level (dBμV)	Antenna Factor (dB/m)	Cable Loss (dB)	Preamp Factor (dB)	Ant Pos (cm)	Table Pos (deg)	Peak Avg. (P/A)	Pol. (H/V)
802.11n HT40 CH 38		10380	49.38	-24.62	74	59.64	38.65	10.1	59.01	250	0	P	H
5190MHz		10380	49.76	-24.24	74	60.02	38.65	10.1	59.01	250	0	P	V
802.11n HT40 CH 46		10460	48.12	-25.88	74	58.26	38.74	10.15	59.03	250	0	P	H
5230MHz		10460	48.74	-25.26	74	58.88	38.74	10.15	59.03	250	0	P	V
Remark	1. No other spurious found. 2. All results are PASS against Peak and Average limit line.												



Band 2 - 5250~5350MHz
WIFI 802.11a (Band Edge @ 3m)

Table with 14 columns: WIFI, Note, Frequency, Level, Over, Limit, Read, Antenna, Cable, Preamp, Ant, Table, Peak, Pol. It contains two main sections of data for 802.11a channels 52 and 60.



802.11a CH 64 5320MHz	*	5320	106.67	-	-	99.9	32.96	7.38	33.57	187	215	P	H
	*	5320	95.77	-	-	89	32.96	7.38	33.57	187	215	A	H
		5352.16	65.09	-8.91	74	58.26	32.97	7.39	33.53	187	215	P	H
		5350.72	50.4	-3.6	54	43.57	32.97	7.39	33.53	187	215	A	H
	*	5320	101.25	-	-	94.48	32.96	7.38	33.57	244	8	P	V
	*	5320	92.33	-	-	85.56	32.96	7.38	33.57	244	8	A	V
		5353.6	56.56	-17.44	74	49.73	32.97	7.39	33.53	244	8	P	V
		5350.24	45.91	-8.09	54	39.08	32.97	7.39	33.53	244	8	A	V
Remark	<ol style="list-style-type: none"> No other spurious found. All results are PASS against Peak and Average limit line. 												



Band 2 5250~5350MHz
WIFI 802.11a (Harmonic @ 3m)

WIFI Ant. 1	Note	Frequency (MHz)	Level (dBμV/m)	Over Limit (dB)	Limit Line (dBμV/m)	Read Level (dBμV)	Antenna Factor (dB/m)	Cable Loss (dB)	Preamp Factor (dB)	Ant Pos (cm)	Table Pos (deg)	Peak Avg. (P/A)	Pol. (H/V)
802.11a CH 52		10520	48.35	-25.65	74	58.39	38.84	10.18	59.06	250	0	P	H
	5260MHz	10520	50.22	-23.78	74	60.26	38.84	10.18	59.06	250	0	P	V
802.11a CH 60		10600	49.37	-24.63	74	59.28	38.95	10.29	59.15	250	0	P	H
	5300MHz	10600	48.54	-25.46	74	58.45	38.95	10.29	59.15	250	0	P	V
802.11a CH 64		10640	49.34	-24.66	74	59.18	39	10.34	59.18	250	0	P	H
	5320MHz	10640	48.65	-25.35	74	58.49	39	10.34	59.18	250	0	P	V
Remark	1. No other spurious found. 2. All results are PASS against Peak and Average limit line.												



Band 2 5250~5350MHz
WIFI 802.11n HT20 (Band Edge @ 3m)

WIFI Ant. 1	Note	Frequency (MHz)	Level (dBμV/m)	Over Limit (dB)	Limit Line (dBμV/m)	Read Level (dBμV)	Antenna Factor (dB/m)	Cable Loss (dB)	Preamp Factor (dB)	Ant Pos (cm)	Table Pos (deg)	Peak Avg. (P/A)	Pol. (H/V)
802.11n HT20 CH 52 5260MHz		5121.68	48.78	-25.22	74	42.39	32.92	7.16	33.69	219	213	P	H
		5060.06	38.95	-15.05	54	32.63	32.91	7.15	33.74	219	213	A	H
	*	5260	105.64	-	-	98.91	32.95	7.38	33.6	219	213	P	H
	*	5260	98.49	-	-	91.76	32.95	7.38	33.6	219	213	A	H
		5452.08	48.52	-25.48	74	41.53	32.99	7.47	33.47	219	213	P	H
		5459.28	39.61	-14.39	54	32.62	32.99	7.47	33.47	219	213	A	H
		5032.76	48.85	-25.15	74	42.54	32.91	7.15	33.75	248	72	P	V
		5066.82	38.93	-15.07	54	32.61	32.91	7.15	33.74	248	72	A	V
	*	5260	102.02	-	-	95.29	32.95	7.38	33.6	248	72	P	V
	*	5260	93.11	-	-	86.38	32.95	7.38	33.6	248	72	A	V
		5440.56	47.83	-26.17	74	40.89	32.99	7.43	33.48	248	72	P	V
		5446.32	38.63	-15.37	54	31.65	32.99	7.47	33.48	248	72	A	V
802.11n HT20 CH 60 5300MHz		5139.62	48.89	-25.11	74	42.39	32.93	7.26	33.69	150	251	P	H
		5115.7	39.22	-14.78	54	32.84	32.92	7.16	33.7	150	251	A	H
	*	5300	105.14	-	-	98.37	32.96	7.38	33.57	150	251	P	H
	*	5300	98.63	-	-	91.86	32.96	7.38	33.57	150	251	A	H
		5352.48	56.88	-17.12	74	50.05	32.97	7.39	33.53	150	251	P	H
		5351.76	47.97	-6.03	54	41.14	32.97	7.39	33.53	150	251	A	H
		5078.52	47.62	-26.38	74	41.27	32.92	7.15	33.72	200	114	P	V
		5114.4	39.25	-14.75	54	32.87	32.92	7.16	33.7	200	114	A	V
	*	5300	101.02	27.02	74	94.25	32.96	7.38	33.57	200	114	P	V
	*	5300	93.26	39.26	54	86.49	32.96	7.38	33.57	200	114	A	V
	5352.24	51.39	-22.61	74	44.56	32.97	7.39	33.53	200	114	P	V	
	5352.24	51.39	-22.61	74	44.56	32.97	7.39	33.53	200	114	A	V	



802.11n HT20 CH 64 5320MHz	*	5320	103.89	-	-	97.12	32.96	7.38	33.57	100	261	P	H
	*	5320	96.39	-	-	89.62	32.96	7.38	33.57	100	261	A	H
		5351.84	59.07	-14.93	74	52.24	32.97	7.39	33.53	100	261	P	H
		5350.08	49.02	-4.98	54	42.19	32.97	7.39	33.53	100	261	A	H
	*	5320	99.76	-	-	92.99	32.96	7.38	33.57	100	261	P	V
	*	5320	92.21	-	-	85.44	32.96	7.38	33.57	100	261	A	V
		5351.68	55.97	-18.03	74	49.14	32.97	7.39	33.53	100	261	P	V
		5350.08	45.82	-8.18	54	38.99	32.97	7.39	33.53	100	261	A	V
Remark	<ol style="list-style-type: none"> No other spurious found. All results are PASS against Peak and Average limit line. 												



Band 2 5250~5350MHz
WIFI 802.11n HT20 (Harmonic @ 3m)

WIFI Ant. 1	Note	Frequency (MHz)	Level (dBμV/m)	Over Limit (dB)	Limit Line (dBμV/m)	Read Level (dBμV)	Antenna Factor (dB/m)	Cable Loss (dB)	Preamp Factor (dB)	Ant Pos (cm)	Table Pos (deg)	Peak Avg. (P/A)	Pol. (H/V)
802.11n HT20		10520	50.11	-23.89	74	60.15	38.84	10.18	59.06	250	0	P	H
CH 52		10520	50.38	-23.62	74	60.42	38.84	10.18	59.06	250	0	P	V
5260MHz													
802.11n HT20		10600	50.94	-23.06	74	59.48	39.96	10.65	59.15	250	0	P	H
CH 60		10600	50.94	-23.06	74	59.48	39.96	10.65	59.15	250	0	P	V
5300MHz													
802.11n HT20		10640	49.12	-24.88	74	58.96	39	10.34	59.18	250	0	P	H
CH 64		10640	48.83	-25.17	74	58.67	39	10.34	59.18	250	0	P	V
5320MHz													
Remark	1. No other spurious found. 2. All results are PASS against Peak and Average limit line.												



Band 2 5250~5350MHz
WIFI 802.11n HT40 (Band Edge @ 3m)

WIFI Ant. 1	Note	Frequency (MHz)	Level (dBμV/m)	Over Limit (dB)	Limit Line (dBμV/m)	Read Level (dBμV)	Antenna Factor (dB/m)	Cable Loss (dB)	Preamp Factor (dB)	Ant Pos (cm)	Table Pos (deg)	Peak Avg. (P/A)	Pol. (H/V)	
802.11n HT40 CH 54 5270MHz		5089.96	48.29	-25.71	74	41.93	32.92	7.16	33.72	150	360	P	H	
		5136.76	39.61	-14.39	54	33.11	32.93	7.26	33.69	150	360	A	H	
	*	5270	102.14			95.41	32.95	7.38	33.6	150	360	P	H	
	*	5270	94.58			87.85	32.95	7.38	33.6	150	360	A	H	
		5354.16	54.37	-19.63	74	47.54	32.97	7.39	33.53	150	360	P	H	
		5352.48	46.26	-7.74	54	39.43	32.97	7.39	33.53	150	360	A	H	
		5041.34	47.88	-26.12	74	41.57	32.91	7.15	33.75	250	244	P	V	
		5066.04	39.27	-14.73	54	32.95	32.91	7.15	33.74	250	244	A	V	
	*	5270	96.4			89.67	32.95	7.38	33.6	250	244	P	V	
	*	5270	88.58			81.85	32.95	7.38	33.6	250	244	A	V	
		5355.84	51.89	-22.11	74	45.06	32.97	7.39	33.53	250	244	P	V	
		5350.8	42.21	-11.79	54	35.38	32.97	7.39	33.53	250	244	A	V	
	802.11n HT40 CH 62 5310MHz		5148.46	48.39	-25.61	74	41.87	32.93	7.26	33.67	150	211	P	H
			5141.7	39.36	-14.64	54	32.86	32.93	7.26	33.69	150	211	A	H
*		5310	96.34	-	-	89.57	32.96	7.38	33.57	150	211	P	H	
*		5310	89.25	-	-	82.48	32.96	7.38	33.57	150	211	A	H	
		5351.36	56.02	-17.98	74	49.19	32.97	7.39	33.53	150	211	P	H	
		5350.56	49.83	-4.17	54	43	32.97	7.39	33.53	150	211	A	H	
		5012.74	48.32	-25.68	74	42.04	32.9	7.15	33.77	244	20	P	V	
		5042.38	39.23	-14.77	54	32.91	32.91	7.15	33.74	244	20	A	V	
*		5310	93.47	-	-	86.7	32.96	7.38	33.57	244	20	P	V	
*		5310	86.84	-	-	80.07	32.96	7.38	33.57	244	20	A	V	
	5350.24	56.43	-17.57	74	49.6	32.97	7.39	33.53	244	20	P	V		
	5350.4	45.93	-8.07	54	39.1	32.97	7.39	33.53	244	20	A	V		
Remark	1. No other spurious found. 2. All results are PASS against Peak and Average limit line.													



Band 2 5250~5350MHz
WIFI 802.11n HT40 (Harmonic @ 3m)

WIFI Ant. 1	Note	Frequency (MHz)	Level (dBμV/m)	Over Limit (dB)	Limit Line (dBμV/m)	Read Level (dBμV)	Antenna Factor (dB/m)	Cable Loss (dB)	Preamp Factor (dB)	Ant Pos (cm)	Table Pos (deg)	Peak Avg. (P/A)	Pol. (H/V)
802.11n HT40 CH 54		10540	48.68	-25.32	74	58.67	38.86	10.23	59.08	250	0	P	H
5270MHz		10540	49.25	-24.75	74	59.24	38.86	10.23	59.08	250	0	P	V
802.11n HT40 CH 62		10620	48.48	-25.52	74	58.33	38.98	10.34	59.17	250	0	P	H
5310MHz		10620	49.92	-24.08	74	59.77	38.98	10.34	59.17	250	0	P	V
Remark	1. No other spurious found. 2. All results are PASS against Peak and Average limit line.												



Emission below 1GHz

WIFI 802.11a (LF @ 3m)

WIFI	Note	Frequency	Level	Over	Limit	Read	Antenna	Cable	Preamp	Ant	Table	Peak	Pol.
Ant.				Limit	Line	Level	Factor	Loss	Factor	Pos	Pos	Avg.	
1		(MHz)	(dBμV/m)	(dB)	(dBμV/m)	(dBμV)	(dB/m)	(dB)	(dB)	(cm)	(deg)	(P/A)	(H/V)
802.11a LF		42.61	29.61	-10.39	40	41.56	20.82	0.62	33.39	103	67	P	H
		112.45	31.41	-12.09	43.5	45.2	18.55	0.99	33.33	-	-	P	H
		243.4	32.71	-13.29	46	46.74	17.68	1.4	33.11	-	-	P	H
		415.09	26.98	-19.02	46	32.16	25.66	1.89	32.73	-	-	P	H
		533.43	27.53	-18.47	46	33.53	24.23	2.13	32.36	-	-	P	H
		928.22	32.35	-13.65	46	31.72	29.01	2.77	31.15	-	-	P	H
		42.61	35.67	-4.33	40	47.62	20.82	0.62	33.39	100	291	P	V
		112.45	27.75	-15.75	43.5	41.54	18.55	0.99	33.33	-	-	P	V
		180.35	26.78	-16.72	43.5	42.23	16.46	1.28	33.19	-	-	P	V
		238.55	28.14	-17.86	46	42.4	17.45	1.4	33.11	-	-	P	V
		414.12	26.09	-19.91	46	31.26	25.68	1.89	32.74	-	-	P	V
		957.32	32.88	-13.12	46	31.49	29.55	2.88	31.04	-	-	P	V
	Remark	1. No other spurious found. 2. All results are PASS against limit line.											



Note symbol

*	Fundamental Frequency which can be ignored. However, the level of any unwanted emissions shall not exceed the level of the fundamental frequency.
!	Test result is over limit line.
P/A	Peak or Average
H/V	Horizontal or Vertical



A calculation example for radiated spurious emission is shown as below:

WIFI	Note	Frequency	Level	Over	Limit	Read	Antenna	Cable	Preamp	Ant	Table	Peak	Pol.
Ant.				Limit	Line	Level	Factor	Loss	Factor	Pos	Pos	Avg.	
1		(MHz)	(dBμV/m)	(dB)	(dBμV/m)	(dBμV)	(dB/m)	(dB)	(dB)	(cm)	(deg)	(P/A)	(H/V)
802.11b		2390	55.45	-18.55	74	54.51	32.22	4.58	35.86	103	308	P	H
CH 01													
2412MHz		2390	43.54	-10.46	54	42.6	32.22	4.58	35.86	103	308	A	H

- Level(dBμV/m) =
Antenna Factor(dB/m) + Cable Loss(dB) + Read Level(dBμV) - Preamp Factor(dB)
- Over Limit(dB) = Level(dBμV/m) – Limit Line(dBμV/m)

For Peak Limit @ 2390MHz:

- Level(dBμV/m)
= Antenna Factor(dB/m) + Cable Loss(dB) + Read Level(dBμV) - Preamp Factor(dB)
= 32.22(dB/m) + 4.58(dB) + 54.51(dBμV) – 35.86 (dB)
= 55.45 (dBμV/m)
- Over Limit(dB)
= Level(dBμV/m) – Limit Line(dBμV/m)
= 55.45(dBμV/m) – 74(dBμV/m)
= -18.55(dB)

For Average Limit @ 2390MHz:

- Level(dBμV/m)
= Antenna Factor(dB/m) + Cable Loss(dB) + Read Level(dBμV) - Preamp Factor(dB)
= 32.22(dB/m) + 4.58(dB) + 42.6(dBμV) – 35.86 (dB)
= 43.54 (dBμV/m)
- Over Limit(dB)
= Level(dBμV/m) – Limit Line(dBμV/m)
= 43.54(dBμV/m) – 54(dBμV/m)
= -10.46(dB)

Both peak and average measured complies with the limit line, so test result is “PASS”.



Appendix C. Duty Cycle Plots

Band	Duty Cycle(%)	T(ms)	1/T(kHz)	VBW Setting
802.11a	87.44	1.36	0.73	1kHz
802.11n HT20	86.70	1.28	0.78	1kHz
802.11n HT40	76.12	0.64	1.57	3kHz

802.11a

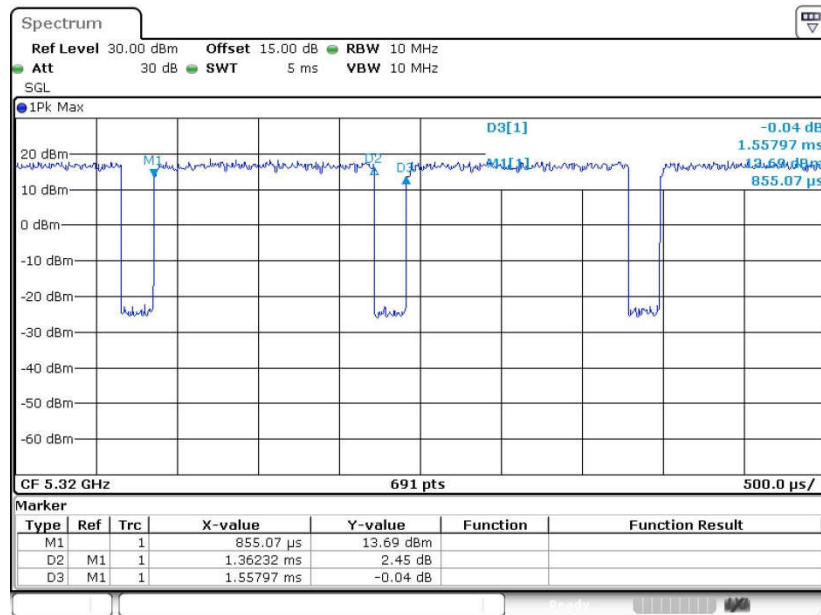

Date: 14.JUL.2016 17:52:30



802.11n HT20

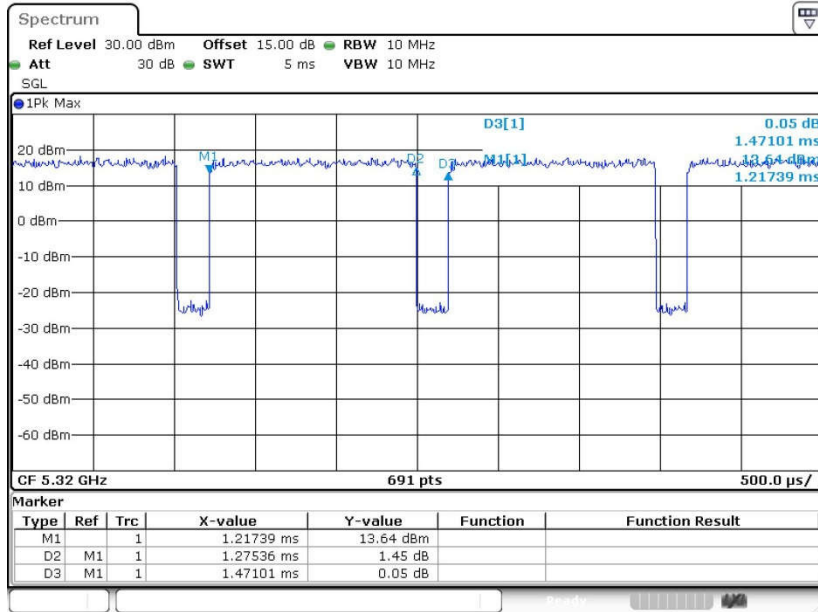

Date: 14.JUL.2016 17:51:48

802.11n HT40

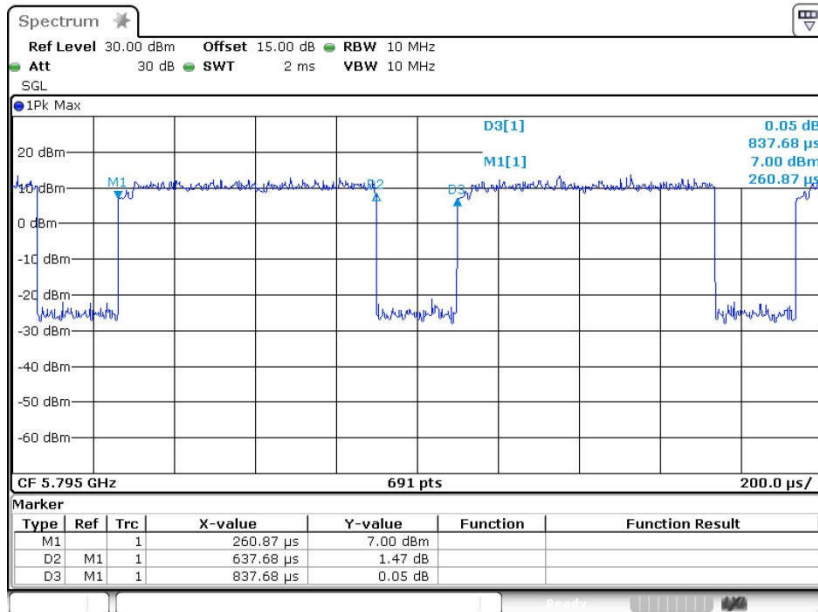

Date: 14.JUL.2016 19:02:58