

东莞市德弗力五金电子材料有限公司
Dongguan city DFL Electronic Technology Co.,LTD

SPECIFICATION

产品型号: DESC	XL-Y-Y20. 5X41-12-FR	版本 Rev:A	Customer:	XL-Y
			Description:	线圈+硬磁
			Date:	20201126

一、尺寸DIMENSION: (mm)

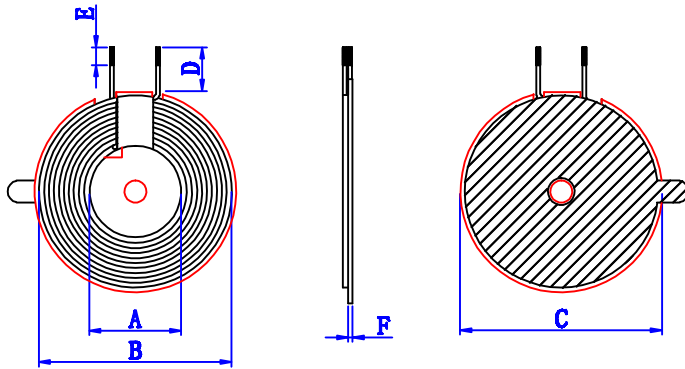

A	20.5±1.0
B	40.0±2.0
C	44.0±1.0
D	12.0±2.0
E	3.0±1.5
F	0.8±0.15
G	
H	
I	

注:

1. 线圈反贴圆形磁片, 磁片带双槽, 有孔
2. 线圈出线位置缠8mm 高温胶带
4. 磁片背面贴带耳朵 双面胶
5. 线圈不可松线

二、原理图 (schematic diagram:)

三、绕线参数(WindingSpecification:)

序号 NO.	端子 TERMINAL	线径 WIRE	圈数 Turns	绕线方向 Winding Direction
1		0.08X24PX2P热风线	10TS	逆时针

四、电气特性ELECTRICALCHARACTERISTICS:

温度TEMPERATURE:25±10° C, 湿度RELATIVE HUMIDITY:65±20%

序号 NO.	项目 ITEM	端子 TERMINAL	标准 SPECIFICATION	测试条件 TEST FREQUENCY	测试仪器 TEST EQUIPMENTS
1	IND.		6.5uH±10% 加磁片	100khz/1.0v	SHDA 1062
2	IND.				
3	Q值				
4	DCR				

拟制/日期 PREPARED BY/DATE	审核/日期 CHECKED BY/DATE	客户/日期 CUSTOMER/DATE