

PREFACE

Thank you for selecting a Hero MotoCorp **DESTINI 125 XTEC**. We wish you many miles of continued riding pleasure in the years ahead.

We at Hero MotoCorp, are committed to demonstrate excellence in our environment performance on a continual basis, as an intrinsic element of our corporate philosophy. To achieve this we commit ourselves to continue product innovations to improve environment compatibility, comply with all applicable legislation including environment legislation and strengthen the green supply chain.

Your vehicle is conforming to latest (Bharat stage-VI norms) regulation for emission, safety & noise levels. We are also using non asbestos brake shoes/pads and engine gaskets which are environment friendly in nature.

This vehicle is fitted with a lighting feature known as “Automatic Headlamp ON”. The feature is mandated for all 2 Wheelers by Ministry of Road Transport & Highways (Government of India) vide notification GSR 188 (E) dated 22nd February 2016. This feature helps in conspicuity for improving rider safety. The headlamp of this vehicle will always be lit ON when the engine gets ON.

This booklet is your guide to the basic operation and maintenance of your new Hero MotoCorp **DESTINI 125 XTEC**. Please take time to read it carefully. As with any fine machine, proper care and maintenance are essential for trouble-free operation and optimum performance.

Your Authorised Hero MotoCorp dealer will be glad to provide further information or assistance and is equipped to handle your future service needs.

Let us make this world a safer, healthier and more environment friendly place.

 **NOTE**

ALL INFORMATION, ILLUSTRATION, PHOTOGRAPH, DIRECTIONS, SPECIFICATIONS AND OTHER CONTENTS COVERED IN THIS OWNER'S MANUAL ARE BASED ON THE LATEST PRODUCT INFORMATION AVAILABLE AT THE TIME OF ITS PRINTING APPROVAL, AND THE ACCURACY OR CORRECTNESS OF THE SAME IS NOT UNDERTAKEN OR GUARANTEED.

Hero MotoCorp Ltd **RESERVES THE RIGHT TO MAKE CHANGES IN ITS CONTENTS AT ANY TIME WITHOUT NOTICE AND/OR INCURRING ANY OBLIGATION, WHATSOEVER. NO ONE IS ALLOWED TO REPRODUCE ANY PART OF THIS PUBLICATION WITHOUT OBTAINING PRIOR WRITTEN PERMISSION FROM** Hero MotoCorp Ltd.

ACCESSORIES SHOWN MAY NOT BE THE PART OF STANDARD FITMENT. IT IS OUR ENDEAVOUR TO CONSTANTLY IMPROVE OUR PRODUCTS. THIS COULD LEAD TO CHANGE IN PRODUCT SPECIFICATIONS WITHOUT NOTICE. Hero MotoCorp Ltd **'DESTINI 125 XTEC' COMPLIES WITH THE LATEST EMISSION NORMS.**

CONTENTS

	Pg. No.		Pg. No.
VEHICLE IDENTIFICATION	1	• Center cover	48
VEHICLE SPECIFICATION	2	• Body cover	49
VEHICLE SAFETY	5	• Front upper cover	51
• Important safety information	5	• Rear view mirror	52
• Protective apparel	6	• Headlamp assembly	53
• Load limits and guidelines	8	• Headlamp focus adjustment	54
• Accessories and modifications	9	PRE-RIDE INSPECTION	54
SAFE RIDING TIPS	10	ANTI-THEFT TIPS	55
TIPS FOR HEALTHY ENVIRONMENT	11	STARTING THE ENGINE	56
VEHICLE VIEWS	12	RUNNING IN/RIDING	58
PARTS FUNCTION	15	PARKING	63
• Instruments and indicators	15	TOOL KIT/FIRST AID KIT	64
• LCD panel	21	CLEANING/WASHING OF VEHICLE	64
• Low fuel indicator	24	WASHING OF VEHICLE	64
• Keys	25	MAINTENANCE	66
MAJOR COMPONENTS	25	SAFETY PRECAUTIONS	67
• Brakes (Integrated Braking)	25	MAINTENANCE SCHEDULE	68
• Rear brake	26	AIR CLEANER ELEMENT	71
• Fuel	27	THROTTLE OPERATION	72
• Tyres (Tubeless)	29	AIR CLEANER DRAIN TUBE CLEANING	73
ESSENTIAL INDIVIDUAL COMPONENTS	33	ENGINE OIL	74
• Ignition switch	33	FINAL DRIVE OIL REPLACEMENT	76
HANDLEBAR SWITCHES CONTROL	34	SPARK PLUG	77
FEATURES	35	BRAKE SHOE WEAR	77
• i3s (Idle Stop Start System)	35	BATTERY	78
• Hero ride guide	37	FUSE REPLACEMENT	80
• Steering lock	40	SUSPENSION	81
• Fuel filler cap/Lock/Seat lock Helmet holder	41	BULB/LED REPLACEMENT	81
• Center compartment	42	CATALYTIC CONVERTER	84
• Document compartment/First aid kit/Tool kit holder	42	EVAPORATIVE EMISSION CONTROL SYSTEM	85
• Boot lamp/Boot lamp switch/USB charger	43	POLISHING OF VEHICLE	85
• Luggage hook	44	REMOVING ROAD SALT	85
• Inner rack or Front box/Side stand indicator	44	STORAGE GUIDE	86
• Side stand switch/Side stand	45	BASIC TROUBLESHOOTING	87
• Pillion footrest	46	ROAD SIGNS	90
BODY PARTS REMOVAL	47	WARRANTY DETAILS	
• Center compartment	48	HERO GENUINE PARTS	
	48	ZONAL/REGIONAL/AREA OFFICES	

VEHICLE IDENTIFICATION



Vehicle Identification Number (VIN)

Location: Stamped on the lower right side of the frame, visible from the window provided on right floor side cover.

VIN: MBLJFW24#####

MBL	JFW24	#	#	#	#	#####
Manufacturer code	Vehicle Description	Check Digit	Model Year	Plant Code	Month of Manufacturing	Production Serial Number

Engine No.

Location: Stamped on the lower side of the left crankcase.

Engine No.: JF17EA#####

JF17EA	#	#	#	#####
Engine Description	Year of Manufacturing	Assembly Plant	Month of Manufacturing	Serial Number

Model: DESTINI 125 XTEC

Variants	VIN	Engine
Cast wheel/Integrated braking (Destini 125 XTEC VX variant)	JFW24	JF17EA
Sheet metal wheel/Integrated braking (Destini 125 LX variant)	JFN07	JF17EA
Sheet metal wheel/Integrated braking (Destini 125 STD variant)	JFN07	JF17EL

VIN and Engine number may be required:

1. During registration of the vehicle.
2. For dealing with legal & insurance departments.

VEHICLE SPECIFICATION

ITEM		SPECIFICATIONS
Dimensions		
Overall length		1809 mm
Overall width		729 mm
Overall height	VX & LX variant	1135 mm
	STD variant	1154 mm
Wheelbase		1245 mm
Saddle height		778 mm
Ground clearance		155 mm
Weight		
Kerb weight	VX variant	114 kg
	LX variant	115 kg
	STD variant	114.5 kg
Capacities		
Engine oil		0.80 litre at disassembly and 0.70 litre at draining
Transmission (Final drive) oil		0.12 litre at disassembly
		0.10 litre at draining
Fuel tank		5.0 litres
Engine		
Maximum power		6.7 kW @ 7000 r/min
Maximum torque		10.4 N-m @ 5500 r/min
Bore and stroke		52.4x57.8 mm
Compression ratio		9.8±0.2:1
Displacement		124.6 cc
Spark plug		Champion-RG8YC (Federal Mogul)
Spark plug gap		0.8-0.9 mm
Valve clearance	Intake (cold)	0.14 mm
	Exhaust (cold)	0.14 mm
Idle speed		1500±100 r/min

VEHICLE SPECIFICATION

ITEM		SPECIFICATIONS
Chassis and suspension		
Frame type		High rigidity under bone
Front suspension		Telescopic, hydraulic shock absorber
Rear suspension		Unit swing with spring loaded hydraulic damper
Caster angle		27.5°
Tyre size	Front	90/100-10 53 J (Tubeless tyre)
	Rear	90/100-10 53 J (Tubeless tyre)
Front brake		Internal expanding shoe type (Dia. 130 mm)
Rear brake		Internal expanding shoe type (Dia. 130 mm) (Integrated braking system)
Transmission		
Primary reduction		Variomatic drive, (2.53-0.8)
Final reduction		50/20x49/14 (8.75)
Clutch system		Dry, automatic centrifugal clutch
Electricals		
Battery		*MF battery 12V-4Ah/ETZ5
Alternator	VX & LX variant	123 W @ 5000 r/min
	STD variant	125 W @ 5000 r/min
Starting system		Kick/Electric start
Headlamp (High/Low)	VX & LX variant	13.2V-20W/16.6W
	STD variant	12V-35/35W Halogen bulb-**MFR
Position lamp		3W (LED)
Tail/Stop lamp		12V-5/21W
Turn signal lamp		12V-10Wx4 nos. (**MFR-Clear Lens-Amber bulb)
Meter illumination	VX & LX variant	LED (White)
	STD variant	LED (White)
Turn signal indicator	VX & LX variant	LED (Green) x2nos.
	STD variant	LED (Green) x2nos.

VEHICLE SPECIFICATION

ITEM		SPECIFICATIONS
Hi beam indicator	VX & LX variant	Blue (LED)
	STD variant	Blue (LED)
Licence plate		12V-5W
Side stand indicator	VX & LX variant	Red (LED)
	STD variant	Red (LED)
LCD illumination	VX variant	Blue (LED)
	LX & STD variant	Amber (LED)
i3s indicator	VX & LX variant	Blue (LED)
	STD variant	Blue (LED)
Boot lamp		12V-30mW (LED)
Programmed FI malfunction indicator lamp (MIL)	VX & LX variant	Amber (LED)
	STD variant	Amber (LED)
Low fuel indicator	VX & LX variant	LED
Fuse	Main fuses	15A, 10A, 10A and 10A
	Spare fuses	15A and 10A

* MF stands for Maintenance Free

** MFR stands for Multi-Focal Reflector

VEHICLE SAFETY

IMPORTANT SAFETY INFORMATION

Your vehicle can provide many years of service and pleasure if you take responsibility for your own safety and understand the challenges you can meet on the road.

There is much that you can do to protect yourself when you ride. You will find many helpful recommendations throughout this manual. Following are a few that we consider most important.

Always wear a helmet

It is a proven fact, Helmet significantly reduces the number and severity of head injuries. So always wear a helmet and make sure your pillion rider does the same. We also recommend that you wear eye protection, sturdy boots, gloves and other protective gear (page 6).

Before riding your vehicle

Make sure that you are physically fit, mentally focused and free of alcohol and drugs. Check that you and your pillion are both wearing an approved vehicle helmet and protective apparel. Instruct your pillion on holding onto the grab rail or your waist, leaning with you in turns, and keeping their feet on the footrest, even when the vehicle is stopped.

Take time to learn & practice your vehicle

Even if you have ridden other vehicles, practice riding in a safe area to become familiar with how this vehicle works and handles, and to become accustomed to the vehicle's size and weight.



Ride defensively

Always pay due attention to other vehicles around you, and do not assume that other drivers see you. Be prepared to stop quickly or perform an evasive maneuver.

Make yourself easily visible

Some drivers do not see vehicles because they are not looking for them. To make yourself more visible, wear bright reflective clothing, position yourself so that others can see you, signal before turning or changing lanes, and use horn which will help others to notice you.

Ride within your limits

Pushing the limits is another major cause of vehicle accidents. Never ride beyond your personal abilities or faster than conditions demand. Remember that fatigue and negligence can significantly reduce your ability to make good judgements and ride safely.

Do not drink and ride

Riding under the influence of alcohol or drugs is dangerous. Alcohol can reduce your ability to respond to changing conditions and reduce the reaction time. Do not drink and ride.

Keep your vehicle in safe condition

For safe riding, it's important to inspect your vehicle before every ride and perform all recommended maintenance. Never exceed load limits, and use accessories that have been recommended by Hero MotoCorp for this vehicle. See (page 7) for more details.

If you are involved in a crash

Personal safety is your first priority. If you or anyone else has been injured, take time to assess the severity of the injuries and whether it is safe to continue riding. Call for emergency assistance if needed. Also follow applicable laws and regulations if another person or vehicle is involved in the crash.

If you decide to continue riding, first evaluate the condition of your vehicle. If the engine is still running, turn it off. Inspect for fluid leaks, check the tightness of critical nuts and bolts, and check the handlebar, brake levers, brakes, and wheels. Ride slowly and cautiously. Your vehicle may have suffered damage that is not immediately apparent. Have your vehicle thoroughly checked at a qualified service facility as soon as possible.

PROTECTIVE APPAREL

For your safety, we strongly recommend that you always wear an approved helmet (ISI marked), eye protection, boots, gloves, long pants and a long sleeve shirt or jacket whenever you ride. Take care of loose/hanging clothes while solo/pillion riding. Although complete protection is not possible, wearing proper gear can reduce the chance of injury when you ride.

Following are suggestions to help you choose proper riding gear.



WARNING

- ***Not wearing a helmet increases the chance of serious injury or death in a crash.***
- ***Be sure you and your pillion always wear a helmet, eye protection and other protective apparel when you ride.***

Helmets and eye protection

Your helmet is your most important piece of riding gear because it offers the best protection against head injuries. A helmet should fit your head comfortably and securely. A bright coloured helmet can make you more noticeable in traffic, as can reflective strips.

An open-face helmet offers some protection, but a full-face helmet offers more. Always wear face shield or goggles to protect your eyes and help your vision.

Additional riding gear

In addition to a helmet and eye protection, we also recommend:

- Sturdy boots with non-slip soles to help protect your feet and ankles.
- Leather gloves to keep your hands warm and help prevent blisters, cuts, burns, and bruises.
- A two wheeler riding suit or jacket for comfort as well as protection. Bright coloured reflective clothing can help make you more noticeable in traffic. Be sure to avoid loose clothes that could get caught on any part of your vehicle.

PROTECTIVE APPAREL

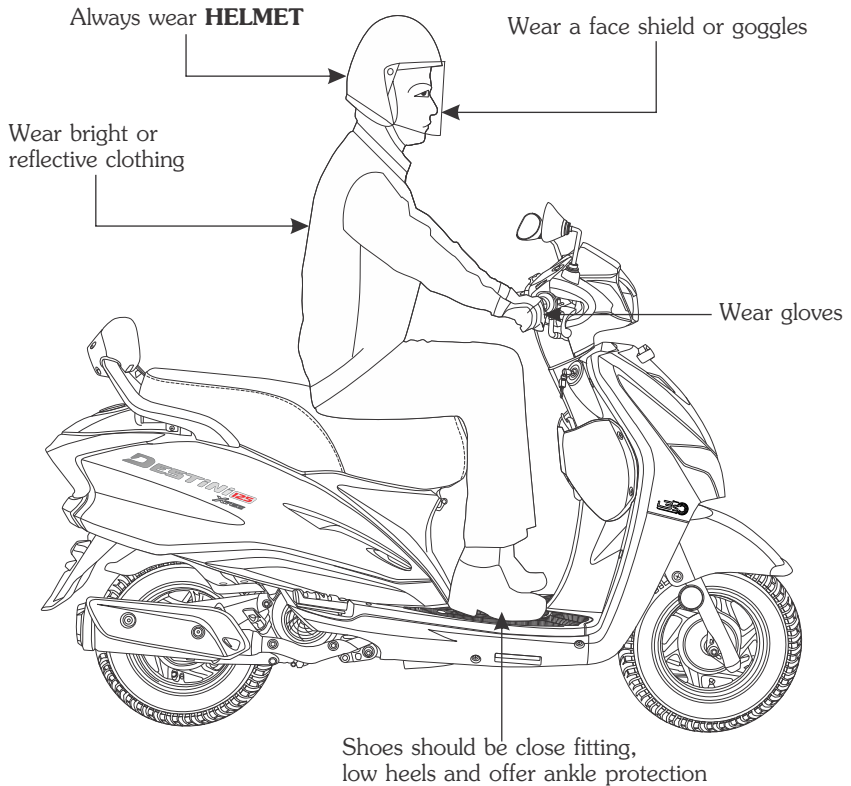

LOAD LIMITS AND GUIDELINES

Your vehicle has been designed to carry you, one pillion and limited amount of cargo. When you add cargo or carry a passenger, you may feel some difference during acceleration and braking. But so long as you keep your vehicle well maintained, with good tyres and brakes, you can safely carry loads within the limits and guidelines.

However exceeding the weight limit or carrying an unbalanced load can seriously affect your vehicle's handling, braking and stability. Non Hero MotoCorp accessories, modifications, and poor maintenance can reduce your safety margin.

The following pages give more specific information on loading, accessories and modifications.

Loading

How much weight you put on your vehicle, and how you load it, are important to your safety. Anytime you ride with a pillion or cargo you should be aware of the following information.

WARNING

- **Overloading or improper loading can cause a crash and you can be seriously injured.**
- **Follow all load limits and other loading guidelines in this manual.**

Load limits

Following are the load limits for your vehicle:

Maximum weight capacity: 130 kg

Includes the weight of the rider, pillion, all cargo and all accessories.

Putting too much weight in individual storage compartments can also affect stability and handling. So be sure to stay within the limits given below:

Maximum weight:

- Center compartment : 10.0 kg
- Inner rack or Front box : 1.5 kg
- Rear luggage hook : 3.0 kg
- Front luggage hook : 3.0 kg

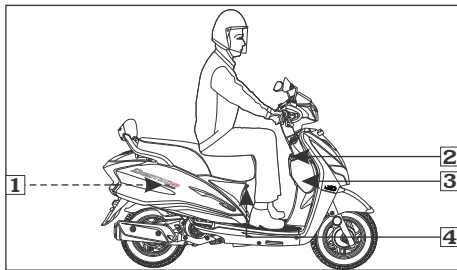

- (1) Center compartment (inside)
- (2) Front luggage hook
- (3) Inner rack
- (4) Rear luggage hook

Loading guidelines

Your vehicle is primarily intended for transporting you and a pillion. If you wish to carry more cargo, check with your Authorised Hero MotoCorp workshop for advice and be sure to read the information regarding accessories on (page 8).

Improperly loading your vehicle can affect its stability and handling. Even if your vehicle is properly loaded, you should ride at reduced speeds whenever carrying cargo.

Follow these guidelines whenever you carry a pillion or cargo:

- Check that both tyres are properly inflated.
- To prevent loose items from creating a hazard, make sure the center compartment is closed and that any other cargo is securely tied down before you ride away.
- Place cargo weight as close to the center of the vehicle as possible.
- Balance cargo weight evenly on both sides.

ACCESSORIES & MODIFICATIONS

Modifying your vehicle or using non Hero MotoCorp accessories can make your vehicle unsafe. Before you consider making any modifications or adding any accessory, be sure to read the following information.



WARNING

- ***Improper accessories or modifications can cause a crash in which you can be seriously hurt or killed.***
- ***Follow all instructions in this owner's manual regarding accessories and modifications.***

Accessories

We strongly recommend that you use only genuine Hero MotoCorp accessories that have been specifically designed and tested for your vehicle. Hero MotoCorp cannot test all other accessories, you must be personally responsible for proper selection, installation and use of non Hero MotoCorp accessories. Check with your dealer for assistance and always follow these guidelines:

- Make sure the accessories does not obstruct any lamps, reduce ground clearance and banking angle, limit suspension travel or steering travel, alter your riding position or interfere with operating any controls.
- Be sure electrical equipment does not exceed the vehicle's electrical system capacity. A blown fuse can cause loss of lights (**page 4**).
- Do not pull a trailer or sidecar with your vehicle. This vehicle is not designed for these attachments, and their use can seriously impair your vehicle handling.

Modifications

We strongly advise you not to remove any original equipment or modify your vehicle in any way that would change its design or operation. Such changes could seriously impair your vehicle's handling, stability and braking, making it unsafe to ride.

Removing or modifying your lamps, muffler, emission control system or other equipment can also make your vehicle not meeting the emission standards.

SAFE RIDING TIPS



Do's:

- Always conduct simple pre-ride inspection **(page 54)**.
- Always wear a helmet (ISI marked) with chin strap securely fastened and insist on a helmet for your pillion rider.
- While riding, keep your leg closed and sit in a comfortable position.
- Ride defensively and at a steady speed (between **40-50 km/hr**).
- To stop the vehicle (in integrated brake system), press the rear brake lever for the application of front and rear brakes simultaneously. However, for more effective braking, it is advised to apply both front and rear brake simultaneously, keeping the throttle in close position.
- Respect road signs and obey traffic rules for your own safety and that of others on the road **(page 90)**.
- During night time, dip headlamps of your vehicle for oncoming traffic, or when following another vehicle.
- Give way to others on the road and signal before you make a turn.
- To make yourself more visible, wear bright reflective clothing that fits well.
- Take care of loose/hanging clothes while solo/pillion riding.
- Get your vehicle serviced regularly by the Authorised Hero MotoCorp workshop.
- Before riding make sure in which mode you are riding whether with i3s switch "ON" or "OFF".

Don'ts:

- Never use cell phone while riding the vehicle.
- Avoid sudden acceleration, braking and turning of your vehicle.
- Never touch any part of the hot exhaust system like muffler.
- Never ride under the influence of alcohol or drugs.
- Concentrate on the road and avoid talking to the pillion rider or others on the road.
- Do not litter the road.
- Do not cross the continuous white/yellow line in the center of the road, while overtaking.
- Do not attach large or heavy items to the handlebars.
- Never take your hands off the steering handle while riding.
- Do not move the side stand (optional) down while riding, as engine will stop **(page 46)** which can lead to loss of control and accident.

TIPS FOR HEALTHY ENVIRONMENT

The following tips shall ensure a healthy vehicle, healthy environment, and a healthy you.

- **Healthy engine:** The engine is the lifeline of every vehicle. To keep it healthy, it should be tuned regularly, which will also help reduce pollution and improve vehicle performance & fuel efficiency.
- **Regular servicing:** Get your vehicle serviced at an Authorised Hero MotoCorp workshop, as per the service schedule, for an optimum performance and keep the emission level under check.
- **Genuine spares:** Always insist on Hero MotoCorp genuine parts as spurious or incompatible spares and accessories can upset or deteriorate your vehicle's running condition.
- **Genuine engine oil:** Hero 4T Plus SAE 10W 30 SL grade (JASO MB) engine oil recommended by Hero MotoCorp and make sure you change it every 6000 km (with top up every 3000 km) to keep the engine fit and environment healthy.
- **Noise pollution:** Noise beyond a certain decibel is pollution. Whether it is from horns or defective mufflers, excessive noise will cause headaches and discomfort.
- **Emission pollution:** Get emission of your vehicle checked by Authorised agencies atleast once every 3 months or as notified by the government from time to time.
- **Fuel saving & Reduce pollution:** Switch "OFF" the engine while waiting at traffic signal points to save fuel and reduce pollution, if the waiting period is long.
- **BS-VI grade fuel:** Always use BS-VI grade fuel to adhere BS-VI norms.

TOP VIEW

VEHICLE VIEWS

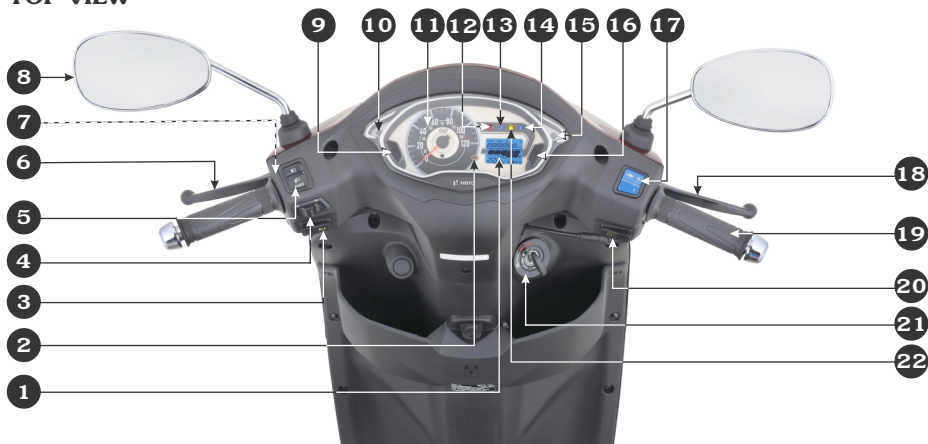

- | | |
|--------------------------------------------------------------------------------------------------------------------------------------------|------------------------------------------------------------------------|
| (1) LCD panel of meter console. Refer instruments and indicators (page 15) for fuel gauge, odometer and other features of console | (11) Speedometer |
| (2) Programmed FI malfunction indicator lamp (MIL) | (12) Side stand indicator |
| (3) Horn switch | (13) i3s indicator |
| (4) Turn signal switch | (14) Hi-beam indicator |
| (5) Dimmer/Passing switch | (15) Right turn signal indicator |
| (6) Integrated brake lever | (16) Set button |
| (7) Lever lock | (17) i3s switch |
| (8) Rear view mirror | (18) Front brake lever |
| (9) Mode button | (19) Throttle grip |
| (10) Left turn signal indicator | (20) Electric starter switch |
| | (21) Ignition switch with steering lock, seat lock and fuel lid opener |
| | (22) Low fuel indicator* |

***For VX & LX variant**
***Accessories and features shown may not be part of standard fitment.**

LEFT SIDE VIEW



- | | | |
|---------------------------|-------------------------------|--------------------------|
| (1) Side reflex reflector | (7) Kick starter pedal | (11) Seat |
| (2) USB charger* | (8) Rear turn signal lamp | (12) Boot lamp* (inside) |
| (3) Side stand switch** | (9) Tail/Stop lamp | (13) Rear luggage hook |
| (4) Side stand** | (10) Rear grip with backrest* | (14) Headlamp |
| (5) Main stand | | |
| (6) Pillion footrest | | |

****Optional in LX & STD variants**

****Optional**

***Accessories and features shown may not be part of standard fitment.**

RIGHT SIDE VIEW



- | | | |
|-------------------------------------------------------|----------------------------|---------------------------------|
| (1) Exhaust muffler | (5) Front fender | (9) Center compartment (inside) |
| (2) Oil level dipstick | (6) Front turn signal lamp | (10) Hugger fender |
| (3) Front luggage hook | (7) Position lamp | (11) Licence plate lamp |
| (4) Inner rack or
Front box** (N/A in STD variant) | (8) Weight end handle* | (12) Rear fender |

*For VX variant

**Optional in LX variants

*Accessories and features shown may not be part of standard fitment.

PART FUNCTIONS INSTRUMENTS AND INDICATORS (VX VARIANT)

The indicators are in the speedometer panel above the headlamp. The functions are as below.

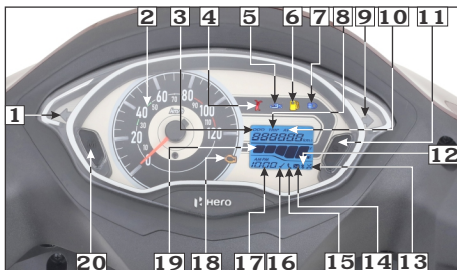

Sl. No.	Description	Function
1	Turn signal indicator (L)	Flashes when left turn signal switch is operated.
2	Speedometer	Indicates riding speed.
3	Odometer	Shows accumulated distance travelled (page 22) .
4	Side stand indicator	Light glows when the vehicle is parked on the side stand. Side stand indicator glows continuously, if any fault detected in the side stand system.
5	i3s indicator	Indicator glows for 2 seconds and turns “OFF” indicating that i3s system is functional.
6	Low fuel indicator	Light glows when the fuel quantity is low (page 24) .
7	High beam indicator	Light glows when headlamp is in high beam.
8	Tripmeter	Shows the distance travelled since the last reset (page 22) .
9	Turn signal indicator (R)	Flashes when right turn signal switch is operated.
10	Real time mileage indicator (RTMI)	It indicates the current mileage of the vehicle (in km/ litre). The indication will change after every 3 seconds depending upon the driving condition (page 23) .

Sl. No.	Description	Function
11	Set button	To adjust clock & tripmeter. When long pressed resets tripmeter to zero.
12	Bluetooth	On pairing (page 37), meter console display bluetooth symbol in bluetooth connected.
13	Missed call alert	If your smartphone is paired with the meter console of your vehicle via bluetooth (page 37), then you will get all the missed call alert on the meter console (page 40).
14	Message alert	If your smartphone (android) is paired with the meter console of your vehicle via bluetooth (page 37), then you will get all the message alert on the meter console (page 40).
15	Incoming call alert	If your smartphone is paired with the meter console of your vehicle via bluetooth (page 37), then you will get all the incoming call alert on the meter console (page 40).
16	Service reminder indicator	Displays when the next service is due (page 24).
17	Digital clock	Indicates hours & minutes (page 21).
18	Programmed-FI malfunction indicator lamp (MIL)	When the ignition switch is turned "ON" the programmed-FI malfunction indicator lamp (MIL) glows continuously until the vehicle starts. It indicates that programmed FI system is OK. If MIL remains "ON" even if the vehicle is started, there is an abnormality in the programmed FI system. It is recommended to reduce the speed and drive to the Authorised Hero MotoCorp workshop for check-up.
19	Fuel gauge	Indicates approximate fuel available in the form of digital segments. The digital segments will swing to maximum scale on the meter console once the ignition switch is turned "ON" (O) (page 24).
20	Mode button	Switches display between odometer, tripmeter & RTMI.

PART FUNCTIONS INSTRUMENTS AND INDICATORS (LX VARIANT)

The indicators are in the speedometer panel above the headlamp. The functions are as below.

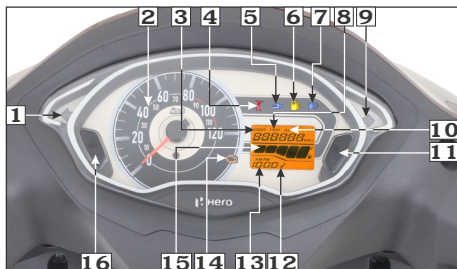

Sl. No.	Description	Function
1	Turn signal indicator (L)	Flashes when left turn signal switch is operated.
2	Speedometer	Indicates riding speed.
3	Odometer	Shows accumulated distance travelled (page 23) .
4	Side stand indicator	Light glows when the vehicle is parked on the side stand. Side stand indicator glows continuously, if any fault detected in the side stand system.
5	i3s indicator	Indicator glows for 2 seconds and turns "OFF" indicating that i3s system is functional.
6	Low fuel indicator	Light glows when the fuel quantity is low (page 24) .
7	High beam indicator	Light glows when headlamp is in high beam.
8	Tripmeter	Shows the distance travelled since the last reset (page 22) .
9	Turn signal indicator (R)	Flashes when right turn signal switch is operated.
10	Real time mileage indicator (RTMI)	It indicates the current mileage of the vehicle (in km/ litre). The indication will change after every 3 seconds depending upon the driving condition (page 23) .

Sl. No.	Description	Function
11	Set button	To adjust clock & tripmeter. When long pressed resets tripmeter to zero.
12	Service reminder indicator	Displays when the next service is due (page 24) .
13	Digital clock	Indicates hours & minutes (page 21) .
14	Programmed-FI malfunction indicator lamp (MIL)	When the ignition switch is turned “ON” the programmed-FI malfunction indicator lamp (MIL) glows continuously until the vehicle starts. It indicates that programmed FI system is OK. If MIL remains “ON” even if the vehicle is started, there is an abnormality in the programmed FI system. It is recommended to reduce the speed and drive to the Authorised Hero MotoCorp workshop for check-up.
15	Fuel gauge	Indicates approximate fuel available in the form of digital segments. The digital segments will swing to maximum scale on the meter console once the ignition switch is turned “ON” (O) (page 24) .
16	Mode button	Switches display between odometer, tripmeter & RTMI.

PART FUNCTIONS INSTRUMENTS AND INDICATORS (STD VARIANT)

The indicators are in the speedometer panel above the headlamp. The functions are as below.

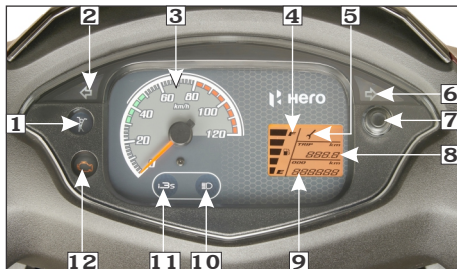

Sl. No.	Description	Function
1	Side stand indicator	Light glows when the vehicle is parked on the side stand.
2	Turn signal indicator (L)	Flashes when left turn signal switch is operated.
3	Speedometer	Indicates riding speed.
4	Fuel gauge	Indicates approximate fuel quantity in the form of digital segments. The fuel gauge segments will display its maximum scale on the fuel gauge LCD panel once when the ignition switch it turned "ON".
5	Service reminder	Displays when a service is due (page 24).
6	Turn signal indicator (R)	Flashes when right turn signal switch is operated.
7	Reset button	Button when long pressed resets tripmeter to zero.
8	Tripmeter	Shows the distance travelled since the last reset (page 23).
9	Odometer	Shows accumulated distance travelled (page 23).

Sl. No.	Description	Function
10	High beam indicator	Light glows when headlamp is in high beam.
11	i3s indicator	Indicator glows for 2 seconds and turns "OFF" indicating that i3s system is functional.
12	Programmed-FI malfunction indicator lamp (MIL)	When the ignition switch is turned "ON" the programmed-FI malfunction indicator lamp (MIL) glows continuously until the vehicle starts. It indicates that programmed FI system is OK. If MIL remains "ON" even if the vehicle is started, there is an abnormality in the programmed FI system. It is recommended to reduce the speed and drive to the Authorised Hero MotoCorp workshop for check-up.

LCD PANEL

(a) Digital clock (VX & LX variant)

Digital clock (1) shows hour and minute. To adjust the time, proceed as follows :

- Turn the ignition switch "ON" (O).
- Press and hold set button (2) and mode button (3) simultaneously for more than 2 seconds. The clock will be set in the adjust mode with the hour's digit blinking.

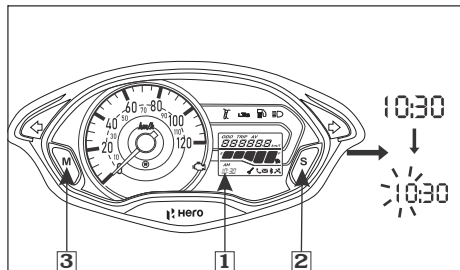

(1) Digital clock (2) Set button
(3) Mode button

- To set the hour, press set button (2) until the desired hour is displayed.
 - The time is advanced by 1 hour each time the button is pressed.
 - The time advances fast when the button is pressed and held.
 - "am" will change to "pm" (after midday).
 - "pm" will change to "am" (before midday).

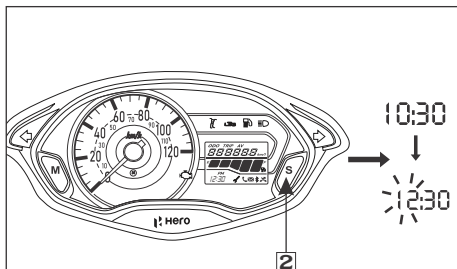

(2) Set button

- Press the mode button (3). The minutes display starts blinking.

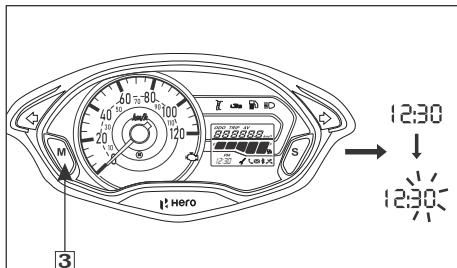

(3) Mode button

- To set the minute press set button (2) until the desired minute is displayed. The minute display will return to "00" when "50" is reached without affecting the hour display.
 - The time advances by 1 minute, each time the button is pressed.

- The time advances fast when the button is pressed and held.

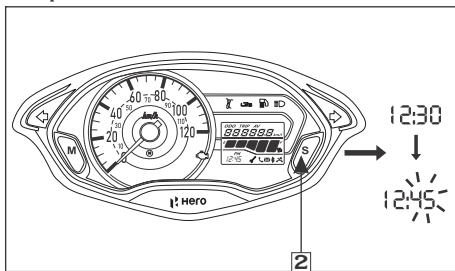

(2) Set button

- To end the adjustment press mode button (3). The display will stop flashing automatically and it will return to its previous value if the button is not pressed for 30 seconds or more.



NOTE

The clock will reset "AM: 1:00" if the battery is disconnected.

(b) Odometer (VX & LX variant)

The odometer (1) shows accumulated distance travelled. The odometer can be selected by pressing the mode button (2).

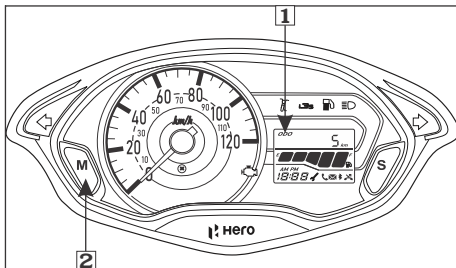

(1) Odometer

(2) Mode button

(c) Tripmeter (VX & LX variant)

The tripmeter (1) shows distance travelled per trip. The tripmeter can be reset to zero by pressing the set button (2) for more than 2 seconds. The tripmeter can be selected by pressing the mode button (3).

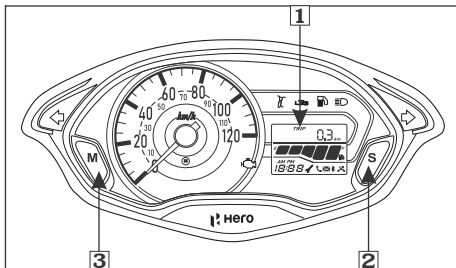

(1) Tripmeter

(2) Set button

(3) Mode button

(d) Odometer/Tripmeter (STD variant)

The odometer (1) shows accumulated distance travelled.

The tripmeter (2) shows distance travelled since trip meter was reset last time.

Tripmeter displays upto 999.9 km If the tripmeter exceeds "999.9" km it will return to "0.0" km automatically.

When tripmeter is selected long press the reset button (3) will reset tripmeter to zero.

The odometer displays from "0 to 999999" km.

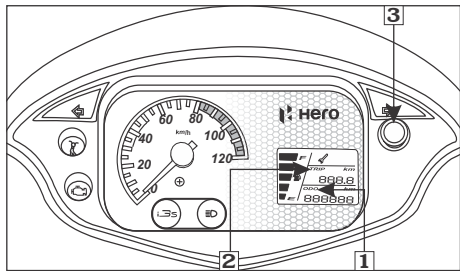

(1) Odometer (2) Tripmeter (3) Reset button

(e) Real time mileage indicator (RTMI) (VX & LX variant)

The real time mileage indicator (RTMI) (1) shows the current mileage of the vehicle in km/litre and is refreshed after every 3 seconds. The real time mileage indicator (RTMI) can be selected by pressing the mode button (2).

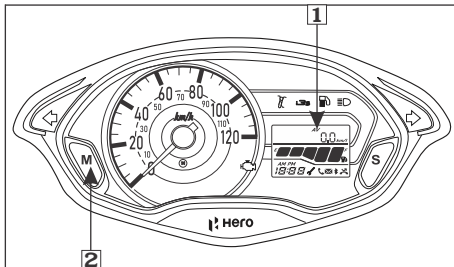

**(1) Real Time Mileage Indicator (RTMI)
(2) Mode button**

When the ignition switch is turned "ON" (Ⓞ) position, the real time mileage indicator will temporarily show the digit "88888.8" which indicates that all the digital LCD segments are working. The display range is from (0 to 99.9 km/litre).

The fuel consumption shall be displayed when the speed of the vehicle is more than 5 ± 2 km/hr. If the speed is less than 5 ± 2 km/hr "---" shall be displayed.

The RTMI shows a minimum value of 0.0km/litre and maximum value of 99.9 km/litre. During coasting with throttle fully closed, the fuel consumption is very minimal and hence the display can go up to 99.9 km/litre.

(f) Fuel gauge

The fuel gauge (1) is of a Liquid Crystal Display (LCD) type.

The approximate amount of fuel quantity available in the fuel tank is indicated by the number of segments (2) in the display.

If all the segments are displayed it means fuel quantity in the fuel tank is approximately 5.0 litres.

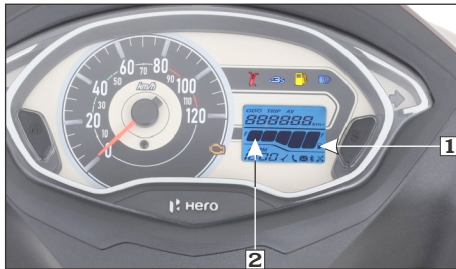

(1) Fuel gauge

(2) Segments

(g) Service reminder

The service reminder (1) is to indicate to a user to bring the vehicle to an Authorised Hero MotoCorp workshop for service.

The service reminder shall start blinking when the vehicle covers kilometers as specified in the maintenance schedule. The service reminder will keep on blinking throughout the kilometer interval for a particular service and will stay "ON" thereafter.

The service reminder can be reset at an Authorised Hero MotoCorp workshop.



(1) Service reminder

NOTE

After getting the vehicle serviced, make sure that the service reminder has been reset.

LOW FUEL INDICATOR (VX & LX variant)

Low fuel indicator (1) is a warning indicator for the user to fill the fuel as soon as possible.

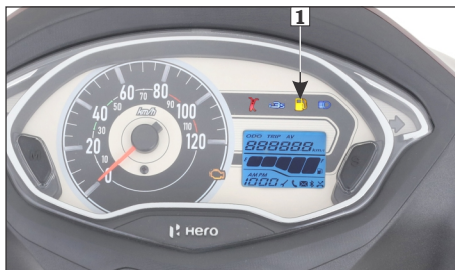

(1) Low fuel indicator

! CAUTION

Please ensure the vehicle is not used with low fuel indicator glowing continuously. It will not only result in the vehicle running out of fuel, it may also cause serious damage to the fuel pump. Please ensure fuel is filled up as soon as the low fuel indicator starts glowing.

NOTE

To check the fuel level indication, the vehicle should be on levelled surface and in stationary condition.

KEYS

This vehicle has two keys and a key number plate.

You will need the key number if you ever have to replace a key. Store the plate in a safe place.

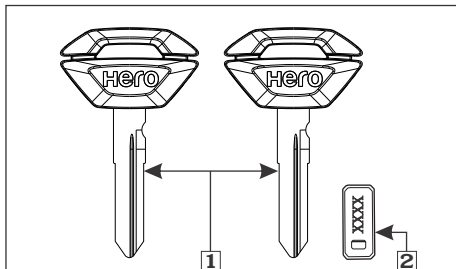

(1) Keys

(2) Key number plate

MAJOR COMPONENTS

(Information you need to operate this vehicle)

BRAKES (INTEGRATED BRAKING)

Brakes are items of personal safety and should always be maintained with proper adjustments. When one applies the left lever, front & rear brakes activate jointly.



(1) Front brake lever (3) Free play: 10-20 mm

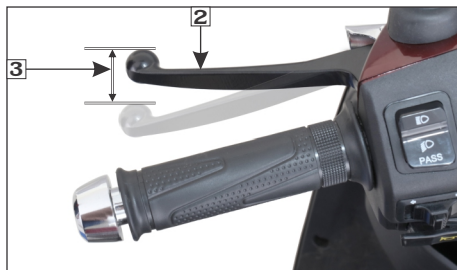

(2) Integrated brake lever
(3) Free play: 10-20 mm

The distance, the front brake lever (1) and integrated brake lever (2) moves before each brake starts to engage is called free play (3).

Measured at the tip of brake levers, free play should be maintained at 10-20 mm.

Right hand front brake cable (A) on "1" side

Adjustment

- Push the integrated brake arm (4) by hand in the direction as shown.
- Turn the first adjuster nut (5) till you cannot turn it by hand.
- Check the free play of right lever.

FREE PLAY: 10-20 mm

- If the free play is more than 20 mm further turn the adjuster nut to obtain desired free play.

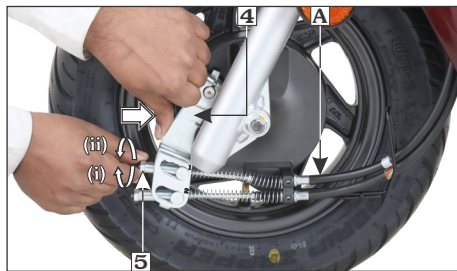

(4) Integrated brake arm (5) First adjuster nut
(i) Decrease free play (ii) Increase free play



NOTE

"1" & "2" is marked on integrated brake arm.

Left hand front brake cable (B) on "2" side

Adjustment

- Push the integrated brake arm (4) by hand in the direction as shown.
- Turn the second adjuster nut (6) until a gap is created between joint (7) and the slot on the first side in integrated brake arm.
- After ensuring the gap, turn the second adjuster nut counterclockwise by half rotation.

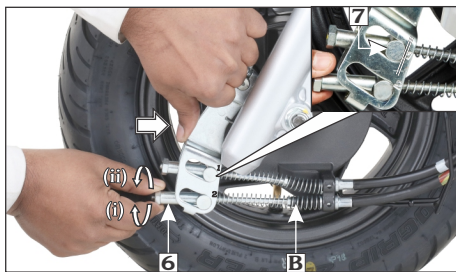

(6) Second adjuster nut (7) Joint
(i) Decrease free play (ii) Increase free play

REAR BRAKE

- Make free play adjustment by turning the adjuster nut (1) in the brake arm (2).
- Check the free play of integrated brake lever.

FREE PLAY: 10-20 mm

- If the free play is more than 20 mm further turn the adjuster nut to obtain desired free play.

Make sure the cut-out on the adjusting nut (3) is seated on the brake joint pin (4) after making final free play adjustment.

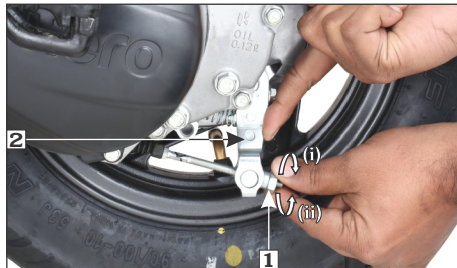

- | | |
|------------------------|-------------------------|
| (1) Adjuster nut | (2) Brake arm |
| (i) Decrease free play | (ii) Increase free play |

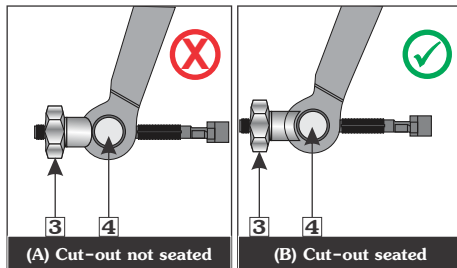

- | | |
|-------------------|---------------------|
| (3) Adjusting nut | (4) Brake joint pin |
|-------------------|---------------------|

If proper adjustment cannot be obtained by this method, visit your Authorised Hero MotoCorp workshop.

Other checks:

- Check brake cable for kinks or signs of wear that could cause sticking or failure.
- Make sure the brake arm spring and fasteners are in good condition.

NOTE

Apply the brake several times and check for free wheel rotation after the brake lever is released.

FUEL

(a) Fuel tank

The fuel tank is located under the seat.

The fuel tank capacity is 5.0 litres (Be sure to fill the fuel tank when low fuel indicator glows).

To open the fuel filler cap (1), insert the ignition key (2), push it in and turn the ignition key to “FUEL OPEN” or in clockwise position (page 25), the lid will open as shown in the picture.



- | | |
|---------------------|------------------|
| (1) Fuel filler cap | (2) Ignition Key |
|---------------------|------------------|

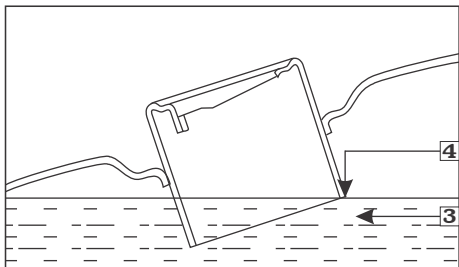

(3) Fuel

(4) Filler neck

Lift the fuel filler cap by hand while refuelling. Do not overfill the tank. There should be no fuel (3) in the filler neck (4).

After refuelling, press the lid gently for locking until a click sound is heard.



We recommend that you use unleaded petrol because the muffler in the vehicle is fitted with a catalytic convertor, it also produces lesser deposits in engine and on spark plug, which extends the life of exhaust system and other components.

NOTE

If "Spark knock" or "pinking" occurs at a steady engine speed under normal load, change petrol brand. If the same still persists, consult your Authorised Hero MotoCorp workshop. Failure to do so is considered misuse, and damage caused by misuse is not covered under Hero MotoCorp warranty policy.

WARNING

- After filling petrol, if the fuel filler cap is not closed and remain open, and the ignition switch is turned to "ON" position, a warning buzzer will sound till either the fuel filler cap is shut/closed, or the ignition switch is turned "OFF" condition.
- Buzzer will also sound till the ignition switch is turned "OFF" too, apart from shut/closure of fuel filler cap.

(b) Petrol containing alcohol

If you decide to use a petrol containing alcohol (gasohol), be sure its octane rating is at least as high as that recommended by Hero MotoCorp.

There are two types of "gasohol", one containing ethanol, and the other containing methanol.

Do not use petrol that contains more than 10% of ethanol.

Do not use petrol containing methanol (methyl or wood alcohol) that does not contain cosolvents and corrosion inhibitors for methanol.

Never use petrol containing more than 5% methanol, even if it has cosolvents and corrosion inhibitors.

- When certain type of petrol containing alcohols are used, problems such as hard starting, poor performance, etc. may occur.
- If you notice any undesirable operating symptoms while using the petrol that contains alcohol, try another station or switch to another brand of petrol.
- When a problem resulting from the use of petrol containing alcohol occurs, contact your Authorised Hero MotoCorp workshop.

CAUTION

Please ensure the vehicle is not used with low fuel indicator glowing continuously. It will not only result in the vehicle running out of fuel, it may also cause serious damage to the fuel pump. Please ensure fuel is filled up as soon as the low fuel indicator starts glowing.

WARNING

- ***Petrol is highly flammable and explosive. You can be burned or seriously injured when handling fuel.***
- ***Stop the engine and keep heat, sparks and flame away.***
- ***Refuel only outdoors.***
- ***Wipe off spills immediately.***

TYRES (TUBELESS)

The tyres fitted on your vehicle are of TUBELESS type. To safely operate your vehicle, your tyres must be of the proper type and size in good condition with adequate tread and correctly inflated for the load you are carrying. The following pages give more detailed information on how and when to check the air pressure, how to inspect your tyres for damage and what to do when your tyres need to be repaired or replaced.

WARNING

- ***Riding on tyres that are excessively worn or improperly inflated can cause a crash in which you can be seriously hurt or killed.***
- ***Follow all instructions in this owner's manual regarding tyres inflation and maintenance.***

Air pressure

Keeping your tyres properly inflated provides the best combination of handling, tread life and riding comfort. Generally, under-inflated tyres wear unevenly, adversely affect handling and are more likely to fail from being overheated.

Over-inflated tyres make your vehicle ride harshly are more prone to damage from road hazards and wear unevenly.

We recommend that you visually check your tyres before every ride and use an air pressure gauge (1) to measure air pressure at least once a month or any time you think the tyre pressure might be low.



(1) Air pressure gauge

Tubeless tyres have some self-sealing ability if they are punctured. However, because leakage is often very slow, you should look closely for punctures whenever a tyre is not fully inflated.

Always check air pressure when your tyres are "cold"—when the vehicle has been parked for at least three hours. If you check air pressure when your tyres are "warm"—when the vehicle has been ridden for even a few km—the readings will be higher than if the tyres were "cold". This is normal, so do not let air out of the tyres to match the recommended cold air pressures given below. If you do, the tyres will be under-inflated.

The recommended "cold" tyre pressures are:

	Rider only	Rider and Pillion
Front	1.50 kgf/cm ² (22 psi)	1.50 kgf/cm ² (22 psi)
Rear	2.00 kgf/cm ² (29 psi)	2.50 kgf/cm ² (36 psi)

! CAUTION

Over inflation/Under inflation will affect the performance.

Inspection

Whenever you check the tyre pressure, you should also examine tyre treads & side walls for wear, damage & foreign objects.

Look for:

- Bumps or bulges in the side of the tyre or the tread. Replace the tyre if you find any bumps or bulges.

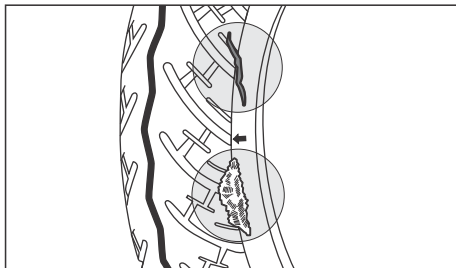

- Cuts, splits or cracks in the tyre. Replace the tyre if you can see fabric or cord.
- Excessive tread wear.

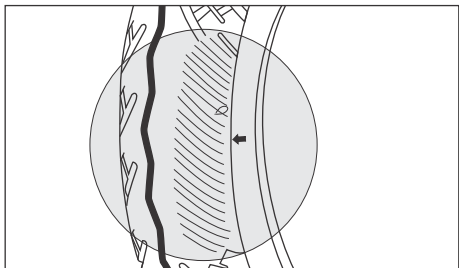

- Carefully inspect the tyres for any damage, if the vehicle hits a pothole or hard object.

Tread wear

Replace tyres immediately when the wear indicator (1) appears on the tyre. The tread limits are :

Minimum tread depth:

Front: 1.0 mm

Rear: 1.0 mm

Check the tread wear indicator for tyre wear.

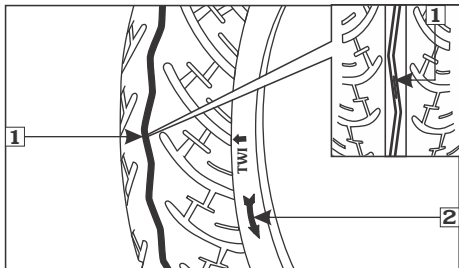

(1) Tyre wear indicator

(2) Arrow mark

Unidirectional tyres

Whenever the tyre is removed and put back in case of puncture, ensure the arrow mark (2) on the tyre is in the same direction as that of forward rotation of wheel.

Tyre repair

Repairing a puncture or removing a wheel requires special tools and technical expertise. If a tyre is punctured or damaged, it is advised to visit nearest tyre manufacture, Hero MotoCorp authorised dealer/workshop or the tyre repair shop who has expertise in repairing methods of tubeless tyre.

A tyre that is repaired either temporarily or permanently, will have lower speed and performance limits than a new tyre. After an emergency repair, always have the tyre inspected/replaced at our authorised dealer and replace the tyre if suggested.

You should not exceed **70 km/hour** for the **1st 24 hours** or **105 km/hour** at any time thereafter. In addition, you may not be able to safely carry as much load as with a new tyre.

If you decide to have a tyre replace be sure the wheel is balanced before you ride.

 **WARNING**

- **Operation with excessively worn tyres is hazardous and will adversely affect traction and handling.**
- **Under-inflation may result in the tyre slipping on or tyre coming off the rim.**
- **Always use the size and type of tyres recommended in this owner's manual.**

Tyre replacement

The tyres that were installed on your vehicle were designed to match the performance capabilities of your vehicle and provide the best combination of handling, braking, durability and comfort.

**NOTE**

The imported tyre(s) if fitted without ISI mark; are in compliance of BIS standard and Central Motor Vehicle Rules 1989, as declared by the Tyre manufacturer.

The recommended tyre for your vehicle are:

Front : 90/100-10 53 J (Tubeless tyre)

Rear : 90/100-10 53 J (Tubeless tyre)

**NOTE**

For repair and replacement of tyre it is advised to visit your Authorised Hero MotoCorp workshop.

Important safety reminders

- Do not install a tube inside a tubeless tyre on this vehicle. Excessive heat buildup can cause the tube to burst.
- Use only tubeless tyres on this vehicle. The rims are designed for tubeless tyres and during hard acceleration or braking, a tube-type tyre could slip on the rim and cause the tyre to rapidly deflate.

ESSENTIAL INDIVIDUAL COMPONENTS

Ignition switch

The ignition switch (1) is on the right side below the steering.

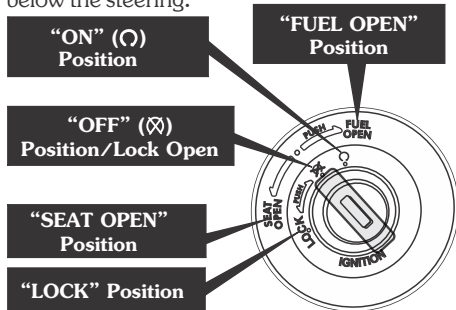



- (1) Ignition switch
- (2) Ignition key
- (3) Steering lock position
- (4) Seat open
- (5) Fuel open

Key Position	Function	Key removal
“ON” (⊙)	The LCD panel illuminates & initial display of multi function digital segments are displayed. The fuel gauge segment will swing to the maximum scale once and back to its normal position. The engine can be started, position lamp, turn signal lamp, horn, tail/stop lamp, fuel gauge will be functional. Programmed FI malfunction indicator lamp (MIL) illuminates continuously and i3s indicator glows for 2 seconds.	Key cannot be removed
“OFF” (⊗)	Engine cannot be started and cannot be operated.	Key can be removed
“LOCK”	Steering can be locked by pushing the key in and rotating it counterclockwise.	Key can be removed
“SEAT OPEN”	Seat can be opened by rotating the key anticlockwise.	Key can be removed
“FUEL OPEN”	Fuel filler cap can be opened by pushing the key in and rotating it clockwise.	Key can be removed

HANDLEBAR SWITCHES CONTROL

Left handlebar controls

1. Dimmer switch/Passing switch

Press the switch upwards for high beam “” and downwards for low beam “”. Press the switch to pass lamp position to operate the pass lamp.

2. Turn signal switch (⇐ ⇨)

Shift the turn signal switch sideways for right/left indications and leave it to come back to its normal position on its own.

IMPORTANT: To switch “OFF” the turn signal after completing the turn, gently push inside as directed on the switch.

3. Horn switch (📢)

Press the horn switch to operate the horn.



- (1) Dimmer switch/Passing switch
- (2) Turn signal switch
- (3) Horn switch

Right handlebar controls

1. Electric starter switch (🔌)

The electric starter switch (1) is next to the throttle grip.

When the starter switch is pressed, the starter motor cranks the engine. See (page 56) for the starting procedure.

2. i3s switch

There is an i3s switch (2) provided to enable the rider for turning i3s mode “ON” or “OFF” based on the traffic conditions.



- (1) Electric starter switch
- (2) i3s switch

NOTE

- *When cranking the engine by using brake & starter switch or brake & slight throttle, cranking of engine will stop after 5 seconds, if engine does not start. After that, brake & starter switch or brake & slight throttle is required to crank the engine.*
- *In case the engine gets started, cranking (starter relay engagement) of engine will stop after engine reaches 900 r/min.*

FEATURES

(a) i3s (Idle stop start system)

Starting & Warm up the engine:

- Turn the ignition key to “ON” (Ⓞ) position.
- The i3s indicator (1) will glow on the meter console for 2 seconds and turn “OFF”. For the activation of i3s system, start the engine and let it idle till the engine gets warmed up (Engine oil temperature read by ECU shall be more than 75°C).

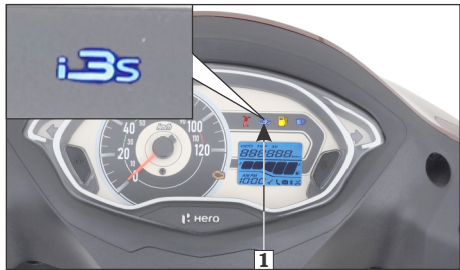

(1) i3s indicator

Initial activation of the i3s system:

- Keep the i3s switch (2) to “ON” position.
- Turn the ignition key to “ON” (Ⓞ) position.
- The i3s indicator on the meter console will glow for 2 seconds and turns “OFF”.
- Put the vehicle in stand still condition on its main stand (Speedometer pointer is on 0 km/h).
- Start the engine and allow it to run at idle r/min.

Ensure that the r/min should not cross 2200.



(2) i3s switch

- The i3s indicator will be continuously “ON” for 8 seconds before engine cuts-off by i3s system (Engine oil temperature read by ECU shall be more than 75°C). After engine cuts-off by i3s, i3s indicator will blink for 500 seconds, waiting user input to start engine by pressing brake & slight throttle, brake & electric start or kick. During this 500 seconds interval, if the vehicle is pushed at speed greater than or equal to 5 km/h, vehicle can be started by applying slight throttle only.
- After 500 seconds, i3s indicator will be “OFF” and the vehicle can only be started by using kick or brake & electric starter.
- If engine is stopped by any means other than i3s function, i3s indicator lamp will not glow/blink in the meter console after engine stop. In this condition, vehicle will not start by brake & slight throttle. Vehicle can be started by using kick or electric start.



NOTE

- If for the first time vehicle is started and rider crosses 20 km/h speed. After that, vehicle is kept in idle (Engine r/min less than 2200 r/min), vehicle is in stationary condition (Speedometer pointer is on 0 km/h), Engine is warmed up (Engine oil temperature read by ECU shall be more than 75°C) then the engine will be turned "OFF" in 8 seconds.
- The i3s indicator will be continuously "ON" for 5 seconds before engine cuts-off by i3s system (Engine oil temperature read by ECU shall be more than 75°C). After engine cut-off by i3s, i3s indicator will blink for 500 seconds, waiting user input to start engine by pressing brake & slight throttle, brake & electric start or kick. During this 500 seconds interval, if the vehicle is pushed at speed greater than or equal to 5 km/h, vehicle can be started by applying slight throttle only.
After 500 seconds, i3s indicator will be "OFF" and the vehicle can only be started by using kick or brake & electric starter.
- If engine is stopped by any means other than i3s function, i3s indicator lamp will not glow/blink in the meter console after engine stop. In this condition, vehicle will not start by brake & slight throttle. Vehicle can only be started by using kick or self start.
- If i3s switch is put on "OFF" position once the engine is stopped by the i3s system then vehicle can only be started by using kick or brake & electric starter.
- After engine is cut-off by i3s, if side stand (optional) position is changed from "Up" to "Down" and then again "Down" to "Up" in

the same ignition cycle, then i3s functionality will be disabled in the vehicle. Hence, after that, vehicle cannot be started by brake & slight throttle. But, if the engine is started by brake & electric start or kick, the i3s operation will be enabled if all i3s conditions are met.

Driving with i3s switch in "ON" position:

If the engine is stopped by i3s and it remains in "OFF" condition for more than 500 seconds then vehicle can only be started with brake & electric starter switch or kick.

Driving with i3s switch in "OFF" position:

While driving in very dense traffic where the vehicle has to encounter a stop and go situation, the i3s switch can be put to "OFF" position. Once this is done, the i3s system will not work and the vehicle will be in normal operating conditions as other vehicles and no special functions will be performed.



NOTE

- The i3s system will not function if rider puts the i3s switch to "OFF" position.
- If the battery voltage is low and engine r/min is less than 2200, there will be 3 continuous blinks after every 6 secs.
- If the low battery voltage is detected while the ignition key is in "ON" position or engine is in running condition, the i3s function will be deactivated until the rider turns the ignition switch to "OFF" (⊗) position and then back to "ON" (⊙) position. The rider can start vehicle by using kick.

- *If the vehicle is driven without battery or with the dead battery and the engine r/min is less than 2200. The i3s indicator on the speedometer will blink continuously at every 1.5 secs. The rider can start vehicle by using kick.*
- *If the vehicle has fallen down, i3s function will be deactivated. Before restarting the engine you must turn the ignition switch to “OFF” (⊗) position and then back to “ON” (⊙) position.*
- *i3s system will be deactivated if the vehicle battery is low/ dead or driven without battery.*
- *If vehicle diagnoses with any problem in electronic control unit (ECU) the i3s function will not work.*
- *If the battery is in healthy condition and the i3s system does not work properly, it is recommended to visit your Authorised Hero MotoCorp workshop.*

(b) Hero ride guide (VX variant)

Application:

Hero ride guide is available in the google play store (for androids) or App Store (for iOS), which can be installed in your device to access bluetooth, incoming calls alerts, missed call alerts and message alert.



NOTE

- **Compatibility and performance of hero ride guide application may vary based on your device and software version.**
- **Application needs GPS signal, internet and bluetooth connectivity to perform the desired functionality.**

Bluetooth:

Your vehicle is equipped with bluetooth connectivity feature by which you can pair your smartphone with the meter console of your **DESTINI 125 XTEC** vehicle through hero ride guide application.

To connect your device proceed as follows:

- Turn the ignition switch “ON”.
- Open hero ride guide application on your smartphone.
- Give access to show incoming call information on digital cluster (1).



(1) Access for incoming call information on digital cluster

- For first time pairing, allow the application to access:
 - a. Contacts
 - b. Make & manage phone calls
 - c. Phone call logs on your device
 - d. Device's location if GPS is not enabled in your device

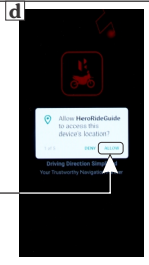
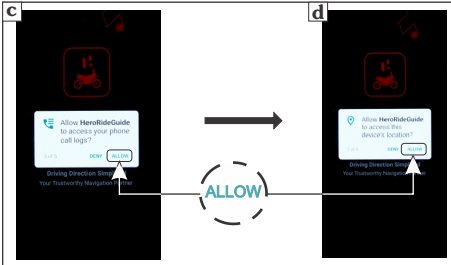
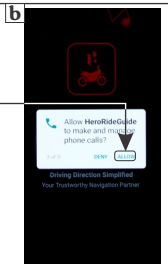
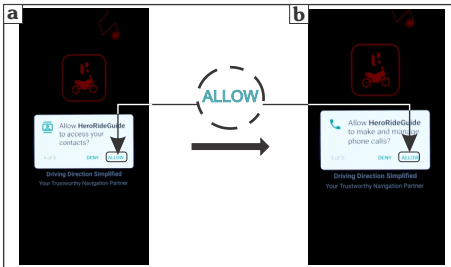

(2) Accept terms of use

- Then the application will automatically start.
- Application also asks you to accept (2) the terms of use to proceed.
- Now select your vehicle (3).
- Now application asks the user to turn the battery optimization off (4). It can be done by following the steps which are mentioned in the application or the user can ignore this step.

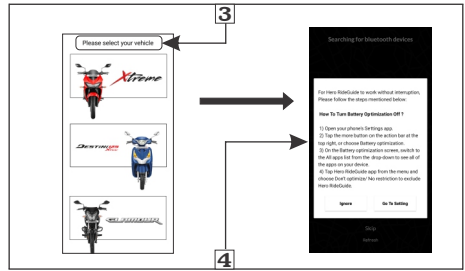

(3) Select your vehicle
(4) Battery optimization

- The application searches for a while and displays all compatible nearby devices. Select the device with your name (5).
- Update your name (6) (if required) and select either save and connect (7) or connect (8) to proceed.



**(5) Select your device (6) Update your name
(7) Save and connect (8) Connect**

- Now application will send pairing request notification (9). Click on the notification.
- Now meter console will display pairing pin (10) in place of odometer reading.
- Enter the pin in application screen and select “OK” (11).

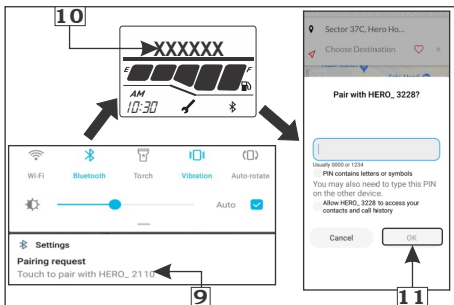

**(9) Pairing request notification
(10) Pin**

(11) “OK”

- On pairing, meter console displays bluetooth symbol (12) which indicates that bluetooth is connected.
- If any error occurs during the course of pairing process, then meter console will not display bluetooth symbol. Repeat the above steps and keep your smartphone closer to the vehicle to reconnect.

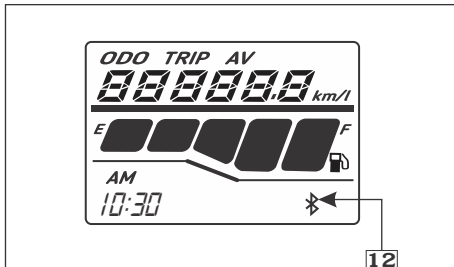

(12) Bluetooth symbol

Autopairing

Your vehicle is equipped with autopairing feature by which if you turn “OFF” vehicle’s ignition switch after successful pairing with hero ride guide application, it will reconnect automatically once ignition switch is turned “ON”.

NOTE

- **Always keep your smartphone close to your vehicle during the course of pairing, autopairing.**
- **Application need to be running in the background.**

Incoming call alert

If your smartphone is paired with the meter console of your vehicle via bluetooth (page 37), then you will get all the incoming calls alerts (1) on the meter console.

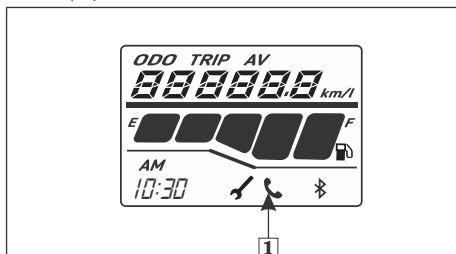

(1) Incoming call alert

Message alert:

If your smartphone (android) is paired with the meter console of your vehicle via bluetooth (page 37), then you will get all the message alerts (1) on the meter console.

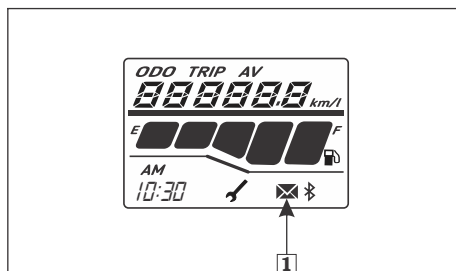

(1) Message alert

Missed call alert:

If your smartphone is paired with the meter console of your vehicle via bluetooth (page 37), then you will get all the missed calls alerts (1) on the meter console.

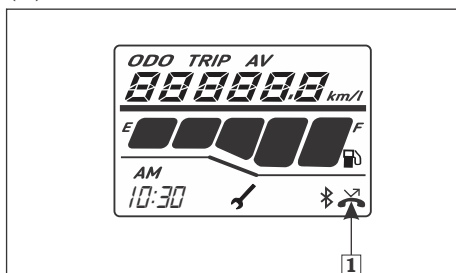

(1) Missed call alert

(c) Steering lock

To lock the steering, turn the handlebar all the way to the left, turn the key (1) to "LOCK" position while pushing in and remove the key.



(1) Ignition switch (A) Push in (B) Turn to lock

! CAUTION

Do not try to turn the key to "LOCK" position while riding the vehicle, which may lead to loss of vehicle control.

(d) Fuel filler cap/lock

The fuel filler cap lock is provided with ignition switch (1).

To open the filler cap, insert the key (2) while pushing in and turn it clockwise to "FUEL OPEN" position. The filler cap will release from its latch.

To lock the filler cap push down gently until it locks and hear a click sound to ensure the fuel filler cap is secured before riding.



(1) Ignition switch

(2) Ignition key

! CAUTION

Gently close the filler cap by hand. Sudden dropping of the filler cap may result in breaking the filler cap lock and malfunction of the lock.

(e) Seat lock

The seat lock is provided along with the ignition switch (1).

To lift the seat, insert the key (2) and turn it anti-clockwise to unlock the seat. The seat will release from its catch.

To lock the seat, push down until it locks. Make sure the seat is secured before riding.

(f) Helmet holder

Two helmet holders (1) are located under the seat.

To access the holder or to secure a helmet (2) to the holder.

- Open the seat.
- Attach/Hook the helmet strap or ring to the helmet holder and close the seat.

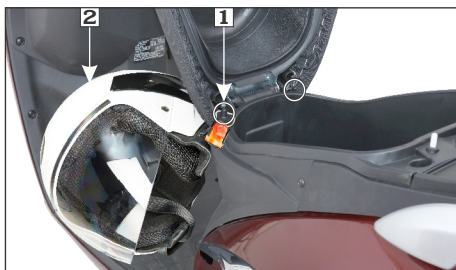

(1) Helmet holder

(2) Helmet

- To release the helmet from the holder.
- Open the seat.

- Remove the helmet from the holder and close the seat.

WARNING

- **Riding with a helmet attached to the holder can interfere with the objects and could cause a loss of control/crash in which you can be seriously hurt.**
- **Use the helmet holder only while parked. Do not ride with a helmet secured by the holder.**

NOTE

Place the helmet inside the luggage compartment if you wish to carry along with the vehicle.

(g) Center compartment

The center compartment (1) is below the seat. Opening and closing the seat lock, see (page 41).

MAXIMUM WEIGHT LIMIT: 10 kg

Never exceed the maximum weight limit, handling and stability may be severely affected. The center compartment may become heated by the engine. Do not store food and other articles which are flammable or susceptible to heat damage.

Do not direct pressurised water spray against the center compartment as water may enter into the compartment.

(h) Document compartment/First aid kit/Tool kit holder

The document compartment (2) and first aid kit/tool kit holder (3) is located in the center compartment below the seat.

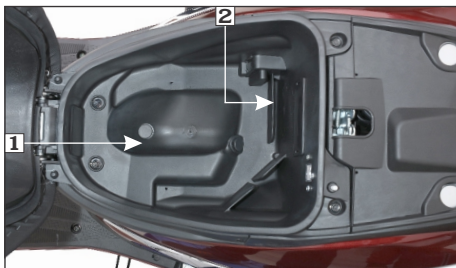

- (1) Center compartment
- (2) Document compartment

The owner's manual, other documents, first aid kit/tool kit can be stored in it.

NOTE

When washing your vehicle, be careful not to flood this area with water.



- (3) First aid kit/Tool kit holder

! CAUTION

Before the vehicle is pressure washed the items kept inside the center compartment should be removed to prevent consequential damage.

(i) Boot lamp (Optional in LX and STD variant)

A boot lamp (1) is provided in the center compartment. This boot lamp will be functional only when the seat is open. For opening and closing the seat lock, see **(page 41)**.



(1) Boot lamp

(2) Switch

(j) Boot lamp switch (Optional in LX and STD variant)

An automated switch (2) is provided on the center compartment, which enables the boot lamp to glow when the seat is in open condition and goes off automatically when the seat is closed.

(k) USB charger (Optional in LX and STD variant)

A USB charger (1) with a cap (2) located on the inner rack (3) is provided in your vehicle to charge your mobile phone safely while riding.

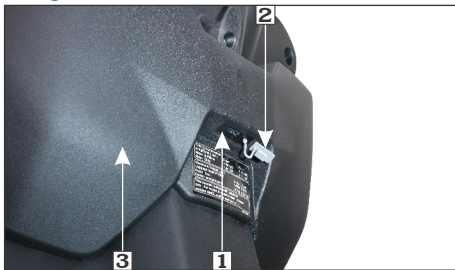

(1) USB charger

(2) Cap

(3) Inner rack

NOTE

In STD variant, USB charger is located inside the center compartment.

Use of non-standard USB cable may cause damage to the mobile phones.

To connect a mobile phone to the charger, first open the cap from the USB charger and then plug in the charger cable to it. Hero MotoCorp will not be responsible for damages caused due to use of non-standard USB cable.

! CAUTION

- *Always place the device in a soft clean cloth/towel to avoid any damage due to road shocks while riding.*
- *Multiple charging of USB devices has to be avoided, simultaneous charging may lead to slow or no charging.*
- *USB port is for charging compatible USB devices.*
- *Do not leave the USB device and USB cable in the inner rack when the vehicle is parked.*
- *Charge your device when the engine is operational/while riding.*
- *USB charger will not be covered under warranty in case of USB charger cap damage.*



NOTE

- *Do not apply any soap solution, oil or grease inside the USB charger.*
- *Any personal belongings have to be removed before water washing to avoid damage.*
- *Always keep the USB port cap closed after use to prevent dust or water entry during rains/water wash.*
- *Do not direct water jet towards the port even with cap closed to avoid any short circuit. Always dry the area using a dry cloth or moisture free compressed air before use.*
- *Press the cap slightly for proper locking of USB charger cap.*
- *The charging time of mobile may vary, depending on the mobile's battery state of the charge, mobile make and conditions.*

(1) Luggage hook

Two luggage hooks (1) are provided in your vehicle to carry a light luggage like shopping bags or carry bags.

Front luggage hook

Front luggage hook (1) is provided below the handlebar.

MAXIMUM WEIGHT LIMIT: 3.0 kg

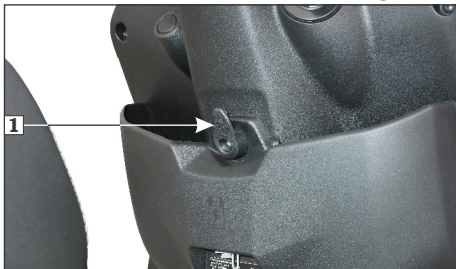

(1) Luggage hook

Rear luggage hook

Rear luggage hook (2) is located below the front end of the seat . To use the hook, push the hook in the downward direction as shown to carry the luggage.



(2) Rear luggage hook

Push back the hook to its original position after use as shown below.

MAXIMUM WEIGHT LIMIT: 3.0 kg



(2) Lock seat hook assy.

⚠ WARNING

- *Do not exceed the maximum weight limits for the luggage hooks.*
- *Do not hang large luggage to the hook that would hang out from the vehicle and or interfere with the movement of your feet.*

**(m) Inner rack or Front box
(Optional in LX variant) &
(N/A in STD variant)**

The inner rack (1) is provided to carry some items, documents, etc.

MAXIMUM WEIGHT LIMIT: 1.5 kg

Never exceed the maximum weight limit of the inner rack otherwise handling and stability may be severely affected.



(1) Inner rack

(n) Side stand indicator

For the safety of the customer, a side stand indicator (1) is provided. If the side stand is down (Ignition switch “ON”), side stand indicator lamp glows in the speedometer panel.

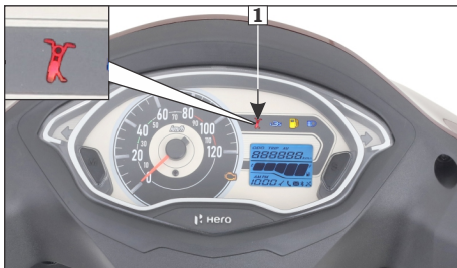

(1) Side stand indicator

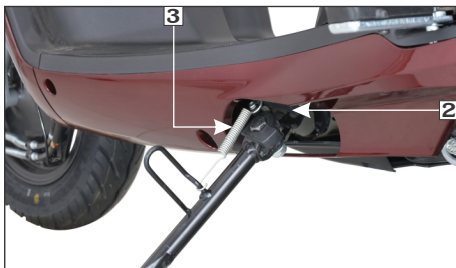

(2) Side stand switch (3) Side stand spring

(o) Side stand switch/Side stand (Optional)

A side stand switch (2) is provided in the side stand, when the side stand is down (ignition switch “ON”), the switch enables the side stand indicator lamp to glow on the speedometer panel.

- Check the side stand for proper function and the spring (3) for damage or loss of tension and the side stand assembly for free movement.
- Check whether the side stand indicator (1) glows when the side stand is down.
- When the side stand is up, the side stand indicator (1) should not glow.
- If the side stand indicator (1) does not operate as described in above steps, please visit your Authorised Hero MotoCorp workshop.

! CAUTION

Ensure that adequate care should be taken while cleaning the side stand switch.

Your vehicle is equipped with “Side stand engine kill” feature for safety purpose.

This feature has following functions:

- It prevents starting the engine when side stand is down.
- It stops the running engine when side stand is moved down.

To inspect the functionality of this feature, park the vehicle on its main stand and check all the conditions described in the inspection flow diagram:

INSPECTION FLOW DIAGRAM

1. Press the electric starter switch (with side stand is “down” and side stand indicator is “ON”).

Does engine start? **YES** → Visit Authorised Hero MotoCorp Workshop

NO ↓

2. Then put the side stand “Up” (side stand indicator is “OFF”) and start the engine.

Does engine start? **NO** → Visit Authorised Hero MotoCorp Workshop

YES ↓

SYSTEM IS OK

⚠ WARNING

- If “Side stand engine kill” feature has any fault, side stand indicator will glow continuously and “Side stand engine kill” feature will not work.
- Regularly inspect the functionality of “Side stand engine kill” feature and in case of any malfunction visit Authorised Hero MotoCorp workshop.

(p) Pillion footrest

Move the left and right (1 & 2) footrest in the direction shown by arrows to open. Folding can be done by moving footrest in the reverse direction.



(1) Left footrest



(2) Right footrest

BODY PARTS REMOVAL

(a) Center compartment Removal

- Open the seat (**page 41**).
- Remove the bolts (1) from the center compartment.



(1) Bolts

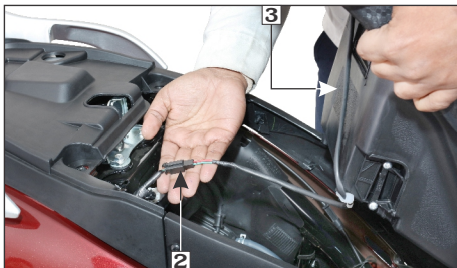

(2) Boot lamp connector
(3) Center compartment

- Slightly lift up the center compartment from the rear and disconnect the boot lamp connector (2).
- Remove the center compartment (3).

Installation

Installation is in the reverse order of removal.



Park the vehicle on its main stand when servicing the vehicle with the center compartment removed.

(b) Center cover Removal

Remove four screws from the center cover.
Remove the center cover (2).



(1) Center cover screws (2) Center cover

Installation

Installation is in the reverse order of removal.

(c) Body cover

Removal

- Remove the center compartment (page 48).
- Remove the center cover (page 48).
- Remove the fuel tray sub assembly bolt (1).
- Remove the fuel tray sub assembly (2).



(1) Bolt (2) Fuel tray sub assembly

- Remove the rear grip bolts (3).

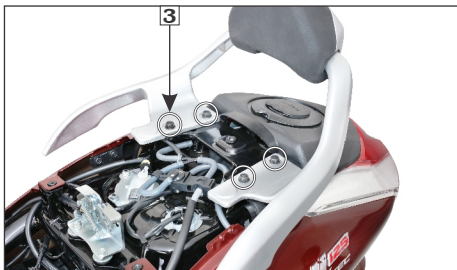

(3) Bolts

- Remove the screws (4).



(4) Screws

- Open the fuel filler cap (5) by turning the ignition key to "FUEL OPEN" or in clockwise position (page 33).
- By pressing the tabs (6), remove the fuel tank lid cover (7).

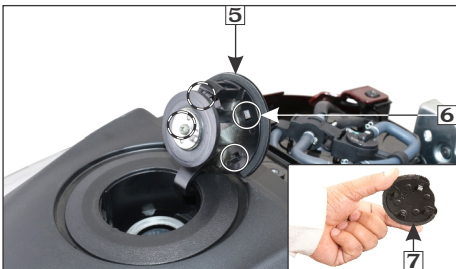

(5) Fuel filler cap

(6) Tabs

(7) Fuel tank lid cover

- Close the fuel tank lid (8) by pressing it.

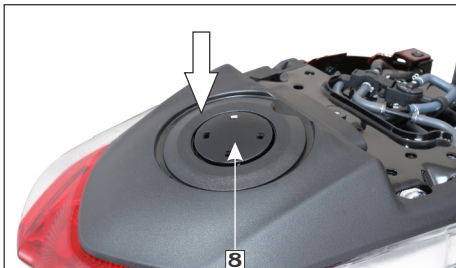

(8) Fuel tank lid

- Remove the fuel tank cap cover (9) by rotating it in anticlockwise direction.



(9) Fuel tank cap cover

- Remove the screws (10) from the fuel tank cover (11) and remove the cover.

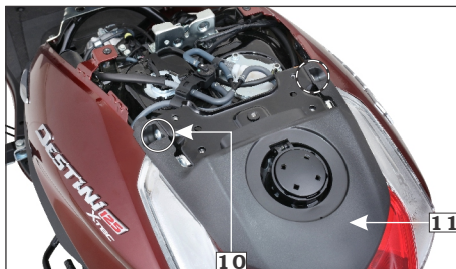

(10) Screws

(11) Fuel tank cover

- Remove the body cover screws (12).

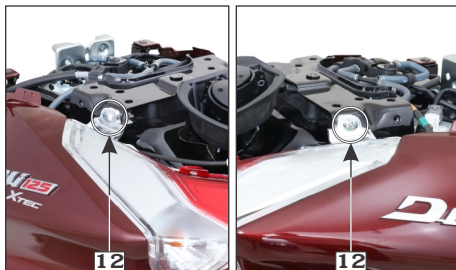

(12) Body cover screws

- Disconnect the tail/stop lamp connector (13).



(13) Tail/stop lamp connector

- Pull the body cover (14) by lifting it from the front and pulling out towards the rear.



(1) Screws

- Remove the two screws (2) from the front end of the vehicle.



(14) Body cover

- Remove the complete body cover.

Installation

Installation is in the reverse order of removal.

(d) Front upper cover

Removal

- Remove the eight screws (1) from the inner side.

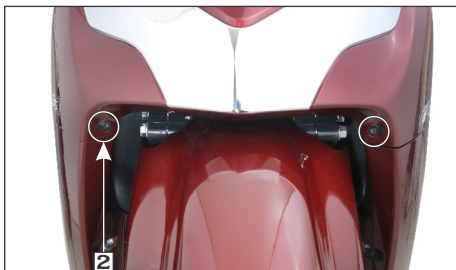

(2) Screws

- Release the front upper cover lug from the grommet (3) and pull it slightly to remove it.
- Disconnect the right turn signal indicator connector (4) and left turn signal indicator connector (5) and disconnect the right position lamp connector (6) and left position lamp connector (7).

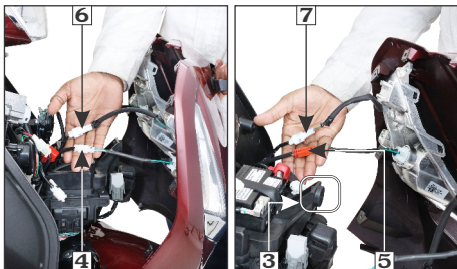

- (3) Grommet
- (4) Right turn signal indicator connector
- (5) Left turn signal indicator connector
- (6) Right position lamp indicator connector
- (7) Left position lamp indicator connector

Installation

Installation is in the reverse order of removal.

(e) Rear view mirror

Chrome mirror (VX variant)

Removal



- (1) Dust cover
- (2) Lock nut
- (3) Rear view mirror

- Slide the dust cover up (1).
- Loosen the lock nut (2).
- Loosen the rear view mirror (3) and remove it.

Installation

- Install the rear view mirror.
- Adjust the rear view mirror and tighten the lock nut.
- Slide the dust cover back to its position.



NOTE

To open the rear view mirror, the lock nut threads are to be loosened in clockwise direction and tightened in anticlockwise direction.

(f) Rear view mirror (LX & STD variant)

Removal

- Slide the dust cover up (1).
- Loosen the lock nut (2) until it will no longer turn.
- Loosen the rear view mirror (3) and remove it.



- (1) Dust cover
- (2) Lock nut
- (3) Rear view mirror

Installation

- Install the rear view mirror until it will no longer turn.
- Loosen the rear view mirror approximately 2 turns.
- Adjust the rear view mirror.
- Tighten the lock nut.



NOTE

To open the right side rear view mirror, the threads are to be loosened in clockwise direction and tightened in counter clockwise direction.

(g) Headlamp assembly

Removal

- Remove the rear view mirror (**page 52**).
- Remove screw (1) from front handlebar cover (2).



(1) Screw

(2) Front handlebar cover

- Remove the screws (3) on rear handlebar cover (4).



(3) Screws

(4) Rear handlebar cover

- Pull the headlamp assembly (5) slightly up, carefully release the tabs (6) from the slots.
- Disconnect the headlamp connector (7) and remove the headlamp case.

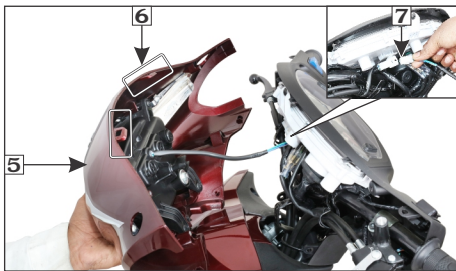

(5) Headlamp assembly

(6) Tabs

(7) Headlamp connector

Installation

Installation is in the reverse order of removal.

(h) Headlamp focus adjustment (VX & LX variant)

Headlamp focus is factory pre-set. However in case of adjustment required, please follow the steps as given below:

- Park the vehicle on its main stand on a level surface in front of a wall.
- Turn the ignition switch to “ON” (ⓐ) position and start the engine.
- Adjust the headlamp beam by loosening or tightening the screw (1) located behind the headlamp assembly for correct focus adjustment.



(1) Screw

WARNING

An improperly adjusted headlamp may blind oncoming rider/driver or it may fail to light the road for safe distance.

(i) Headlamp focus adjustment (STD variant)

Headlamp focus is factory preset. However in case of adjustment required please follow the steps as given below.

- Park the vehicle on its main stand on a level surface in front of a wall.
- Turn the ignition switch to “ON” (ⓐ) position and start the engine.
- Adjust the headlamp beam vertically by loosening the bolt (1) and move the headlamp up (A) or down (B) for correct focus.

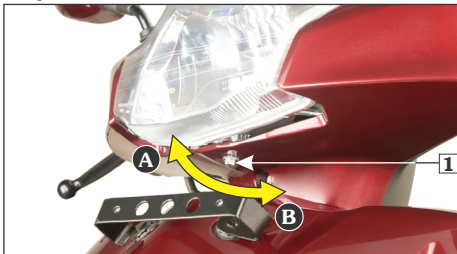

(1) Bolt

(A) Up

(B) Down

WARNING

An improperly adjusted headlamp may blind oncoming rider/driver or it may fail to light the road for safe distance.

PRE-RIDE INSPECTION

For your safety, it is very important to take a few moments before each ride to walk around your vehicle and check its condition. If you detect any problem, be sure you take care of it or have it corrected by your Authorised Hero MotoCorp workshop.

WARNING

- *Improper maintenance or failing to correct a problem before riding can cause a crash in which you can be seriously injured.*

• **Always perform a pre-ride inspection before every ride and correct if any problem.**

- **Engine oil level**—Add engine oil if required (page 74). Check for leaks.
- **Fuel level**—Ensure sufficient fuel is available in your fuel tank for journey (page 24). Check for leaks.
- **Low fuel indicator (VX & LX variant)**—Vehicle should not be operated with low fuel indicator glowing continuously (page 24).
- **Front and Integrated brake**—Check operation and if necessary, adjust free play (pages 25).
- **Tyres**—Check condition and pressure (pages 29).
- **Throttle**—Check for smooth opening and full closing in all steering positions.
- **Lamps and horn**—Check that headlamp, position lamp, tail/stop lamp, turn signal lamps, indicators and horn function properly.
- **Rear view mirrors**—Ensure that the rear view mirrors gives a good view of the rear when you are sitting on the vehicle.
- **i3s switch**—Make sure whether the i3s switch is in “ON” or “OFF” position (page 34).
- **i3s system**—Make sure that i3s system is functional properly (page 35).
- **Fitting & fasteners**—Check & tighten if necessary.
- **Steering**—Check for smooth action for easy maneuverability.

- **Programmed FI malfunction indicator lamp (MIL)**—When the ignition switch is turned “ON” the programmed—FI malfunction indicator lamp (MIL) glows continuously until the vehicle starts.
- **Side stand**—Check for proper functionality (page 46).

ANTI-THEFT TIPS

- **Always lock the steering and never leave the key in the ignition switch.** This sounds simple but people do forget.
- Be sure the registration information for your vehicle is accurate and current.
- Park your vehicle in a locked garage whenever possible.
- Use an additional anti-theft device of good quality.
- Never park your vehicle in an isolated area. Park as far as possible in a designated parking area.
- Enter your name, address, and phone number in this Owner’s Manual and keep it in your vehicle at all times. Many times stolen vehicles are identified by information in the Owner’s Manuals that are still with them.

NAME : _____

ADDRESS : _____

PHONE NO : _____

STARTING THE ENGINE

Always follow the proper starting procedure described below. This vehicle has a fuel injected system

Operate the kick starter or electric starter switch for slightly longer than usual without opening the throttle if the vehicle has been left standing for a long time or when the fuel tank has just been refilled.



NOTE

- **When cranking the engine by using brake & starter switch or brake & slight throttle, cranking of engine will stop after 5 seconds, if engine does not start. After that, brake & starter switch or brake & slight throttle is required to crank the engine.**
- **In case the engine gets started, cranking (starter relay engagement) of engine will stop after engine reaches 900 r/min.**

Your vehicle's exhaust contains poisonous carbon monoxide gas. High levels of carbon monoxide can collect rapidly in enclosed areas such as a garage. Do not run the engine with the garage door closed.

Even with the door open, run the engine only long enough to move your vehicle out of the garage.



CAUTION

- **Do not attempt to start the engine and run the vehicle without a battery. This may lead to electrical and electronic components failure.**
- **This vehicle is equipped with a side stand engine kill feature (page 46).**

- Park the vehicle on its main stand.
- Lock the rear wheel by pressing the integrated brake lever (1) and locking the lever lock (2).

The electric starter will only work when the front or integrated brake lever is operated.

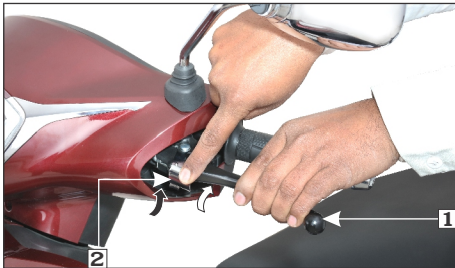

(1) Integrated brake lever (2) Lever lock



WARNING

- **Contact with the rotating rear wheel can injure you.**
 - **Set the lever lock when the vehicle is on its main stand.**
- Turn the ignition switch (3) to “ON” (O) position.
- Confirm that the programmed FI malfunction indicator lamp (MIL) (4) glows continuously and then should go “OFF” once the engine is started.

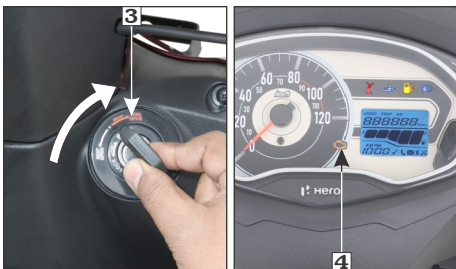

(3) Ignition switch (4) Programmed FI malfunction indicator lamp (MIL)



NOTE

If MIL remains “ON” even if the vehicle is started, there is an abnormality in the programmed FI system. It is recommended to reduce the speed and drive to the Authorised Hero MotoCorp workshop for check-up.

- Make sure whether the i3s switch (5) is in “ON” or “OFF” position.



(5) i3s switch

• Use starter switch:

With the throttle closed, press the starter switch.



NOTE

The engine will not start if the throttle is fully opened as programmed FI system will cut off the fuel supply.

• Use kick starter:

- With the throttle closed, operate the kick starter with a rapid and continuous motion.
- Continue warming up the engine until it runs smoothly and responds to the throttle.



WARNING

- *Do not leave the vehicle unattended while the engine is warming up.*
- *Snapping the throttle or fast idling for more than 5 minutes at normal air temperature may cause exhaust pipe discolouration.*

Starting procedure

At any ambient temperature, turn the ignition switch to “ON” position and press the integrated/rear brake lever, now press the starter switch with the throttle completely closed.



NOTE

- **If you plan to ride your vehicle at an altitude above 2000 meter, consult for advice at Authorised Hero MotoCorp workshop.**
- **While the vehicle is operated at an altitude above 2000 meter, you may not achieve sufficient engine performance. Please visit your Authorised Hero MotoCorp workshop.**
- **The engine will not start if higher throttle is open because the Electronic control unit (ECU) cuts-off the fuel supply.**

Ignition cut off

Your vehicle is designed to automatically stop the engine & fuel pump, if vehicle falls down.

(Bank angle sensor cuts off the ignition).



NOTE

If the vehicle has fallen down, before restarting the engine you must turn the ignition switch to “OFF” (⊗) position and then back to “ON” (⊙) position.

RUNNING-IN

Ensure your vehicle’s future reliability and performance by paying extra attention to how you ride during the first 500 km.

During this period, avoid full-throttle starts and rapid acceleration.

RIDING

Review vehicle safety (**pages 4**) before you ride.

- **Make sure the throttle is closed and the integrated brake is locked** before moving the vehicle off the main stand.

The rear wheel must be locked when moving the vehicle off the main stand or it may result in loss of control.

- **Stand on the left side of the vehicle** and push it forward off the main stand gripping below the seat using the right hand as shown.

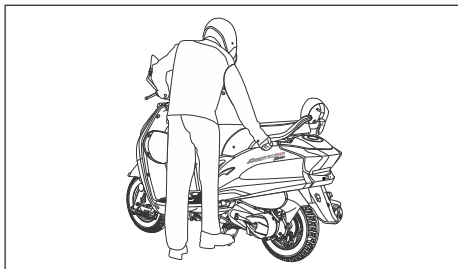

- **Mount the vehicle from the left side** keeping at least one foot on the ground to steady the vehicle.

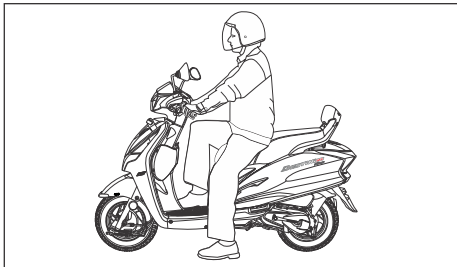

- **Unlock the integrated brake** by further pressing the integrated brake lever (1) so as to release the lever lock (2) from the lock. Then release the brake lever.

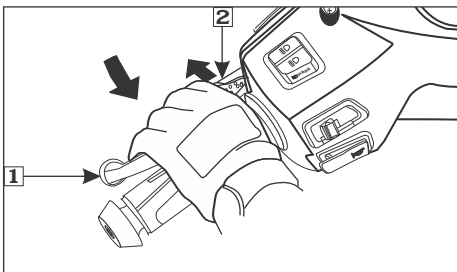

(1) Integrated brake lever (2) Lever lock

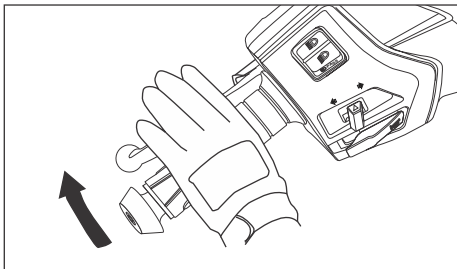

- **Before starting**, indicate your direction with the turn signals, and check for safe traffic conditions. Grab the handle bars firmly with both hands. Never attempt one-handed operation, this could lead to loss of vehicle control.

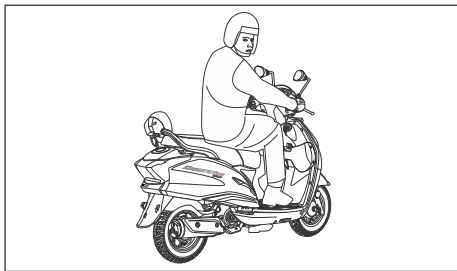

⚠ WARNING

Avoid excessive throttle opening/snapping during idling. It may lead to uncontrolled vehicle movement.

- **To accelerate**, open the throttle (1) gradually, the vehicle will move forward. Do not open and close throttle rapidly, as it will make the vehicle to move forward suddenly, causing possible loss of control and loss of fuel economy. Do not accelerate with the brakes applied, this may lead to premature wear of brakes and transmission parts.
- **To decelerate**, close the throttle.

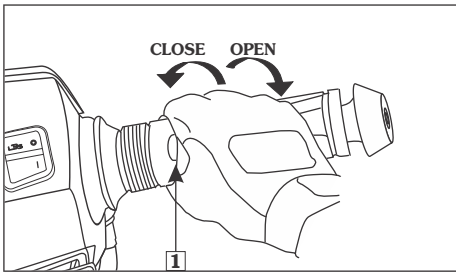
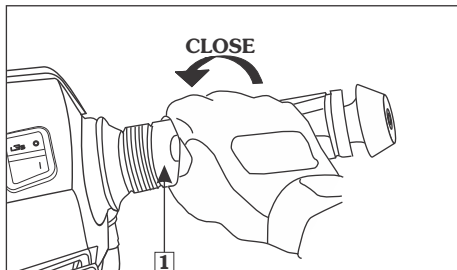

(1) Throttle

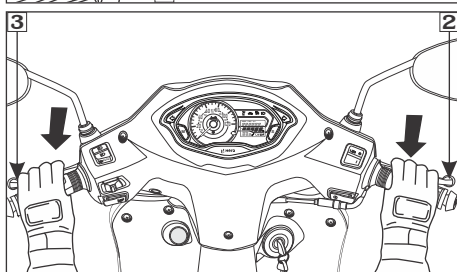

(2) Front brake **(3) Integrated brake**

- **When slowing down the vehicle**, coordination of the throttle (1), front (2) and integrated brake (3) is most important. Since the vehicle is equipped with an integrated braking, by pressing the brake lever provided on the left side of the handlebar would ensure both front and rear brakes applied simultaneously. Excessive brake application may cause the wheels to lock, reducing control over the vehicle.

- **When approaching a corner or turn,** close the throttle (1) fully, and slow down the vehicle by applying integrated brake (2).
- **After completing the turn,** open the throttle gradually to accelerate the vehicle.

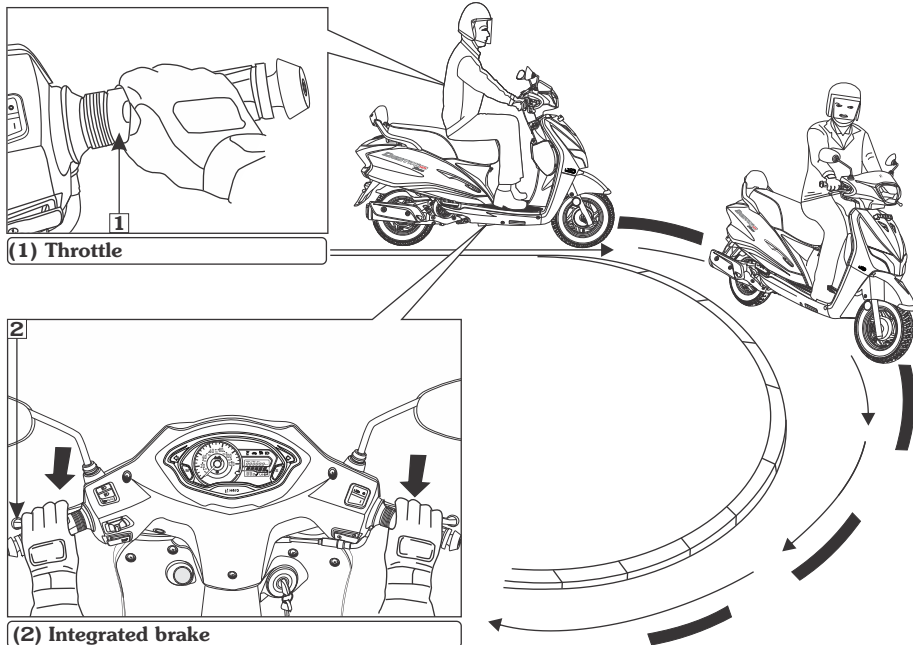

- **When descending a steep gradient,** Avoid continuous use of the brakes, which may result in overheating and reduction of braking efficiency. close throttle (1) fully and apply integrated brake (2) to slow down the vehicle.

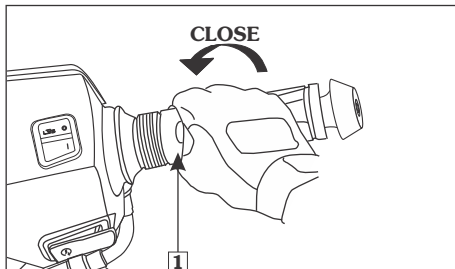

(1) Throttle

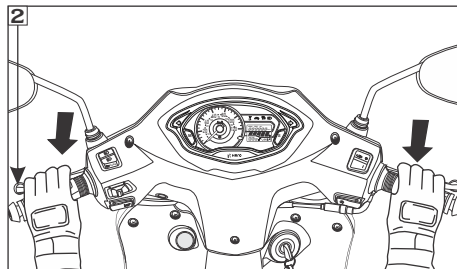

(2) Integrated brake

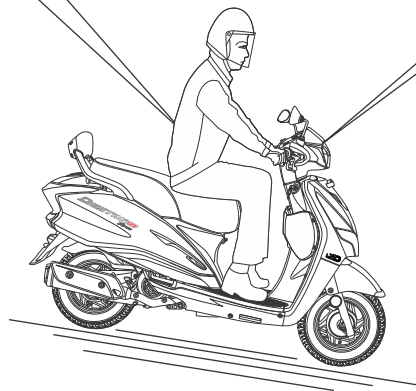

- **When riding on wet or loose surfaces, be cautious.**

When riding in wet or rainy conditions or on loose surfaces, the ability to manoeuvre and stop will be reduced.

- For your safety:
 - Exercise extreme caution when braking, accelerating or turning.
 - Ride at slower speeds and allow for extra stopping distance.
 - Keep the vehicle as upright as possible.
 - Be cautious when riding over slippery surfaces such as railway tracks, iron plates, manhole covers, painted lines, etc.

- **When riding on high altitude.**

- If you plan to ride your vehicle at an altitude above **2000** meter, consult for advice at Authorised Hero MotoCorp workshop.
- While the vehicle is operated at an altitude above **2000** meter, you may not achieve sufficient engine performance. Please visit your Authorised Hero MotoCorp workshop.

PARKING

- After stopping the vehicle turn the ignition switch to “OFF” (⊗) position.
- Use the main stand to support the vehicle while parked, lock and remove the key.
- Lock the steering to prevent theft.

NOTE

- **Park the vehicle on firm, level surface to prevent it from falling over.**
- **If you must park on a slight incline, aim the front of the vehicle uphill to reduce the possibility of rolling off the main stand or overturning.**

CAUTION

The exhaust pipe and muffler become very hot during operation and remain sufficiently hot to inflict burns if touched even after turning off the engine.

HOW TO USE MAIN STAND

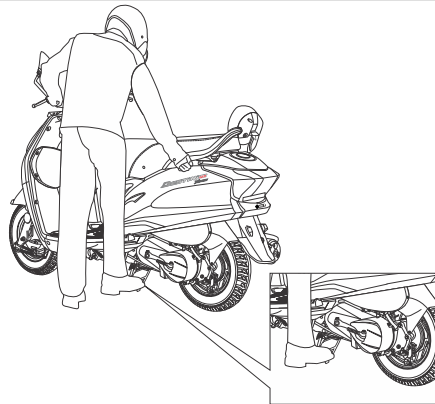

TOOL KIT/FIRST AID KIT

The tool kit (1) is located in the center compartment (2).

Some roadside repairs, minor adjustments and parts replacement can be performed with the tools available in the kit.

- Tool bag-1 No.
- +, - No. 2 driver-1 No.
- Grip-1 No.
- Wrench plug 16-1 No.
- Spanner 14-1 No.



- (1) Tool kit (2) Center compartment
(3) First aid kit

The first aid kit (3) is located in the center compartment (2) along with the tool kit. For some emergency first aid can be performed by medicine available in the kit.

- Antiseptic cream-1 No.
- Sterilised dressing-1 No.
- Water proof plaster-1 No.
- Elastic bandage-1 No.
- Gauze (rolled bandage)-1 No.

- Sterilised elastic plaster-1 No.
- First aid bag-1 No.

CLEANING OF VEHICLE

Clean your vehicle regularly to protect the surface finishes and inspect for damage, wear and oil leakage.

Avoid cleaning products that are not specifically designed for vehicle or automobile surfaces.

They may contain harsh detergents or chemical solvents that could damage the metal, paint and plastic parts on your vehicle.

If your vehicle is still warm from recent operation, give time for the engine and exhaust system to cool down.

We recommend avoiding the use of high pressure water spray.

! CAUTION

- *Our authorised dealership take all above mentioned precautions like recommended detergents and usage of muffler caps/plugs during wash to ensure quality wash.*
- *High pressure water (or air) can damage certain parts of the vehicle.*

WASHING OF VEHICLE

- Rinse the vehicle thoroughly with water to remove loose dirt.
- Clean the vehicle with a sponge or soft cloth using water.
- Avoid directing water to muffler outlets and on electrical parts.

- Clean the plastic parts using a cloth or sponge dampened with a solution of mild detergent and water. Rub the soiled area gently rinsing it frequently with fresh water.



NOTE

- **Take care to keep brake fluid or chemical solvents off the vehicle. They will damage the plastic and painted surfaces.**
- **The inside of the headlamp lens may be clouded immediately after washing the vehicle. Moisture condensation inside the headlamp lens will disappear gradually by lighting the headlamp in high beam.**
- After cleaning, rinse the vehicle thoroughly with plenty of clean water. Strong detergent residue can corrode alloy parts.
- Dry the vehicle with pressurized air, start the engine and let it run for several minutes.

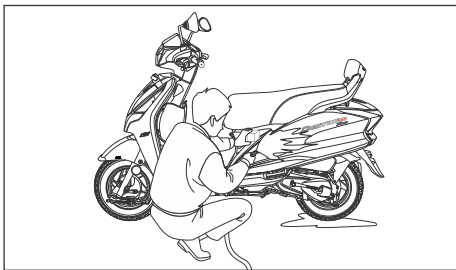

- Test the brakes before riding the vehicle. Several applications may be necessary to restore normal braking performance.

TEST BRAKES

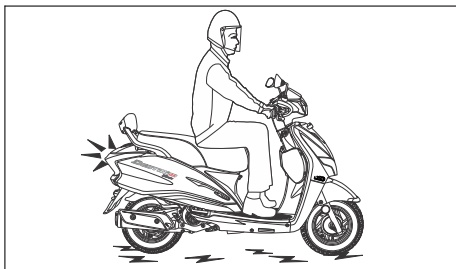
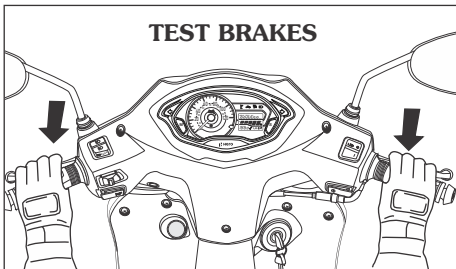

- Braking efficiency may be temporarily impaired immediately after washing the vehicle.
- Anticipate longer stopping distance to avoid a possible accident.

MAINTENANCE

Importance of maintenance

A well maintained vehicle is essential for safe, economical and trouble free riding. It will also help reduce air pollution.

To help you to take proper care for your vehicle, the following pages include a maintenance schedule and a maintenance record for regular scheduled maintenance. These instructions are based on the assumption that the vehicle will be used exclusively for its designed purpose.

Sustained high speed operation or operation in unusually wet or dusty conditions will require more frequent service than specified in the maintenance schedule. Consult your Authorised Hero MotoCorp workshop for recommendations applicable to your individual needs and use.

If your vehicle overturns or is involved in a crash, be sure that you visit your Authorised Hero MotoCorp workshop for detailed inspections.

WARNING

- ***Improperly maintaining this vehicle or failing to correct a problem before you ride can cause an accident in which you can be seriously injured.***
- ***Always follow the inspection and maintenance recommendations and schedules in this owner's manual.***

Maintenance safety

This section includes instructions on some important maintenance tasks. You can perform some of these tasks with the tools provided (if you have basic mechanical skills).

Other tasks that are more difficult and require special tools are best performed by professionals.

It is recommended that wheel removal should normally be handled by a Hero MotoCorp authorised workshop.

You will come across some of the most important safety precautions in the following pages of this manual.

However, we cannot warn you of every conceivable hazard that can arise in performing maintenance. Only you can decide whether or not you should perform a given task.

WARNING

- ***Failure to follow maintenance instructions and precautions properly can seriously injure you.***
- ***Always follow the procedures and precautions in this owner's manual.***

SAFETY PRECAUTIONS

- Make sure the engine is turned “OFF” before you begin any maintenance or repair. This will help eliminate several potential hazards:
 - **Carbon monoxide poisoning from engine exhaust.**
Be sure there is adequate ventilation whenever you start the engine.
 - **Burns from hot parts.**
Let the engine and exhaust system cool before touching.
 - **Injury from moving parts.**
Do not run the engine unless instructed to do so.
- Read the instructions before you begin and make sure you have the tools and skills required.
- To prevent the vehicle from falling over, park it on a firm, level surface, on the main stand.
- Be sure that the integrated brake is locked by lever lock before running the engine, while the vehicle is parked on the main stand. This will prevent the rear wheel from rotating and avoid the possibility of someone being injured from contacting the wheel.
- To reduce the possibility of a fire or explosion, be careful when working around petrol or batteries. Use only nonflammable solvent, not petrol, to clean parts. Keep cigarettes, sparks and flames away from the battery and all fuel-related parts.

Remember that your Authorised Hero MotoCorp workshop knows your vehicle best and is fully equipped to maintain and repair it.

To ensure best quality and reliability, it is recommended to use Hero MotoCorp genuine parts for repair and replacement.

MAINTENANCE SCHEDULE

Perform the pre-ride inspection (**page 54**) at each scheduled maintenance period.

I: INSPECT C: CLEAN R: REPLACE A: ADJUST L: LUBRICATE T: TOP UP
E: EMISSION CHECK

The following maintenance schedule specifies all maintenance required to keep your vehicle in peak operating condition. Maintenance work should be performed in accordance with standards and specifications of Hero MotoCorp by properly trained and equipped technicians. Your Authorised Hero MotoCorp workshop meets all of these requirements.

Ensure that each paid service is availed within **90 days** or **3000 km** from the date of previous service, whichever is earlier.

✖ To be serviced by your Authorised Hero MotoCorp workshop unless the owner has the relevant tools, technical information and is technically qualified.

✘ In the interest of safety, we recommend that these jobs are carried out only by your Authorised Hero MotoCorp workshop.

Note-1 : At higher odometer readings, repeat the frequency interval established here.

Note-2 : Throttle play to be checked and adjusted as per given specification.

Note-3 : Replace air cleaner element once in every **15000 km** or early replacement may be required when riding in dusty areas.

*At **12000 km** inspect if air cleaner element (viscous type) is choked. If found choked, replace the air cleaner element to keep the engine healthy.

*Replace at any point of time, if pre foam and viscous element found damaged.

Note-4 : Service more frequently when riding in rain or at full throttle.

Note-5 : Replace once in every **12000 km**.

Note-6 : Replace engine oil once in every **6000 km**. Top up if the oil level is at or near the lower level mark.

Note-7 : Replace once in every **10000 km** or once in a year, whichever is earlier. Replacement requires mechanical skill.

Note-8 : Replace the pinion starter assembly once in every **2 years** or **21000 km**, whichever is earlier.

Note-9 : Replace drive belt once in every **24000 km**.

Note-10 : Replace the front fork oil once in every **2 years** or **20000 km**, whichever is earlier.

Note-11 : Inspect for any play in the rear suspension mounting bushes, replace if necessary.

Note-12 : Inspect the bearings free play, replace if necessary.

Note-13 : Inspect if side stand switch is installed (as side stand switch is optional).

Note-14 : Check CO emission at idle.

Note-15 : Inspect the canister hoses for deterioration, damage or loose connections and canister for cracks or other damages.



or Scan QR code

MAINTENANCE SCHEDULE

Dear Customer,

We would strongly recommend the following schedule, to keep your vehicle in perfect running condition and healthy environment. Vehicle subjected to severe use or ridden in dusty area will require more frequent servicing.

ITEMS	WHICHEVER COMES FIRST	DURING FREE SERVICE PERIOD					AFTER FREE SERVICE ONCE IN EVERY					
	SERVICE	1 st	2 nd	3 rd	4 th	5 th						
	DAYS	1st 60	Next 100	Next 100	Next 100	Next 100						
	KM Note-1	500-750	3000-3500	6000-6500	9000-9500	12000-12500	3000	6000	9000	12000	15000	
Fuel Lines		I	I	I	I	I	I					
Throttle Operation	Note-2	I, A	I, A	I, A	I, A	I, A	I, A					
Engine Idle Speed		I	I	I	I	I	I					
i3s Switch		I	I	I	I	I	I					
Fuel Tank Lid Cover Operation		I, A	I, A	I, A	I, A	I, A	I, A					
Air Cleaner Element (Pre foam type)	Note-3		I, C	I, C	I, C	I, R*	I, C			I, R*	R	
Air Cleaner Element (Viscous type)	Note-3		I	I	I	I, R*	I			I, R*	R	
Drain/Crankcase Breather Tube	Note-4	I, C	I, C	I, C	I, C	I, C	I, C					
Spark Plug	Note-5	I, C, A	I, C, A	I, C, A	I, C, A	R	I, C, A				R	
Valve Clearance		I, A	I, A	I, A	I, A	I, A	I, A					
Engine Oil	Note-6	R	T	R	T	R	T	R				
Engine Oil Strainer Screen		C		C		C		C				
Final Drive Oil	Note-7				R							
Brake System		C, L	C, L	C, L	C, L	C, L	C, L					
Front/Integrated Brake Lever Free Play		I, A	I, A	I, A	I, A	I, A	I, A					
Brake Shoe Wear		I	I	I	I	I	I					

ITEMS		WHICHEVER COMES FIRST	DURING FREE SERVICE PERIOD					AFTER FREE SERVICE ONCE IN EVERY					
		SERVICE	1 st	2 nd	3 rd	4 th	5 th						
		DAYS	1st 60	Next 100	Next 100	Next 100	Next 100						
		KM Note-1	500-750	3000-3500	6000-6500	9000-9500	12000-12500	3000	6000	9000	12000	15000	
	Lever Lock Operation		I	I	I	I	I	I					
	Battery Voltage		I	I	I	I	I	I					
↘	Stop Lamp Switch		I	I	I	I	I	I					
↘	Headlamp Focus		I	I	I	I	I	I					
✘	Belt Case/Kick Starter Driven Gear		C, L	C, L	C, L	C, L	C, L	C, L					
✘	Pinion Starter Assembly	Note-8				I				I			
✘	Drive Belt	Note-9			I		I		I				
✘	Clutch Shoe Wear				I		I		I				
↘	Nut, Bolt & Fasteners		I	I	I	I	I	I					
	Front Suspension/Oil leakage	Note-10	I	I	I	I	I	I					
↘	Rear Suspension	Note-11	I	I	I	I	I	I					
✘	Wheel/Tyres		I	I	I	I	I	I					
✘	Wheel Bearings	Note-12	I	I	I	I	I	I					
✘	Steering Head Bearings		I, A	I, A	I, A	I, A	I, L, A	I, A				I, L, A	
	Main Stand		L	L	L	L	L	L					
	Side Stand (Optional)		L	L	L	L	L	L					
	Side Stand Switch (Optional)	Note-13	I, C	I, C	I, C	I, C	I, C	I, C					
✘	Muffler (Catalytic Converter)	Note-14			I, E		I, E		I, E				
↘	Evaporative Emission Control System	Note-15	I	I	I	I	I	I					

AIR CLEANER ELEMENT

Refer to the safety precautions (page 67).

The air cleaner element is of pre foam and viscous type, it should be replaced at regular intervals (pages 68). Early replacement may be required when riding in unusually wet or dusty areas.

Removal

- Remove the body cover (page 49).
- Remove the air cleaner cover (1) by removing the screws (2)

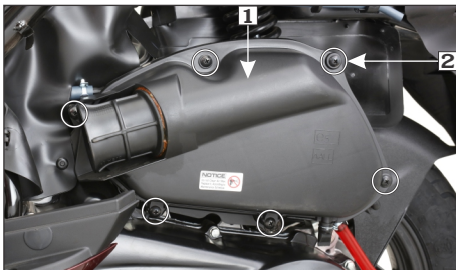

(1) Air cleaner cover

(2) Screws

- Remove the air cleaner element holder component (3) from air cleaner sub assembly case (4).
- Separate the pre foam element (5) from the air cleaner assembly.



(3) Air cleaner element holder component

(4) Air cleaner sub assembly case

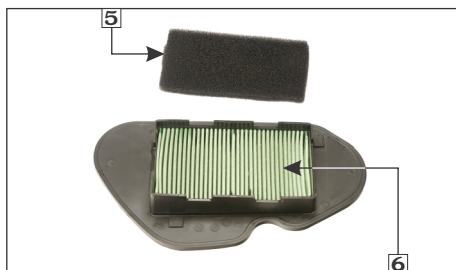

(5) Pre foam element

(6) Viscous air cleaner element

Viscous air cleaner element inspection

- Inspect the viscous air cleaner element (6) for any dust or dirt accumulation.
- Replace the element, if found choked. Refer maintenance schedule (page 68).

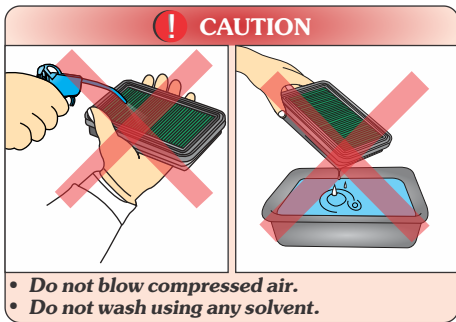

Pre foam element

The pre foam element should be serviced at regular intervals (**page 68**). Service more frequently when riding in unusually wet or dusty areas.

Cleaning

- Wash the pre foam element in kerosene.
- Spread 5ml (4 to 5 drops) of SAE 90 grade at different locations on pre foam element.

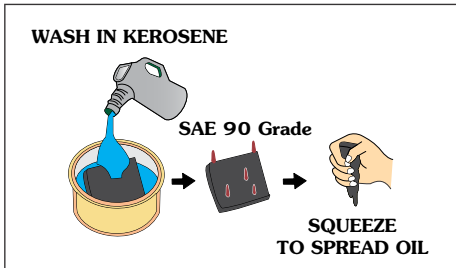

- Squeeze it in a manner so that oil will spread on complete surface of pre foam element.

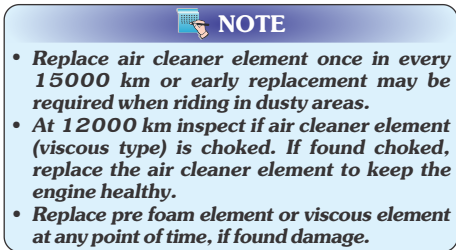

Installation

- Clean the air cleaner sub assembly case (4) using a shop towel.
- Install the pre foam element.
- Install the air cleaner element holder component (new, in case of replacement).
- Install the air cleaner cover.
- Install the body cover (**page 51**).

THROTTLE OPERATION

Cable Inspection

Check for smooth rotation of the throttle grip from the fully open to the fully closed position. Check at full left and full right steering positions. Inspect the condition of the throttle cable from the throttle grip down to the throttle body. If the cable is kinked, chafed or

improperly routed, it should be replaced or rerouted. Standard throttle grip free play (1) is approximately 2–6 mm of grip rotation.



(1) Free play: 2–6 mm

Free play adjustment

(a) At handlebar side

Slide the boot (2), loosen the lock nut (3) and turn the adjuster (4).

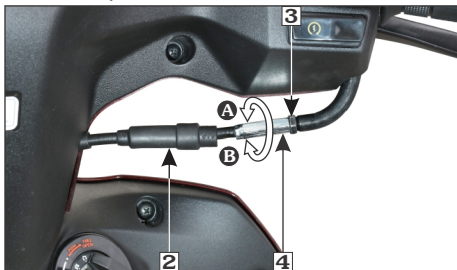

(2) Boot (3) Lock nut (4) Adjuster
(A) Decrease free play (B) Increase free play

If the specified free play is not achieved, adjust the free play on throttle body side.

(b) At throttle body side

Remove the center compartment (page 48).

Loosen the lock nut (5). Turn the adjusting nut (6) to obtain the specified free play. Tighten the lock nut and check the adjustment.

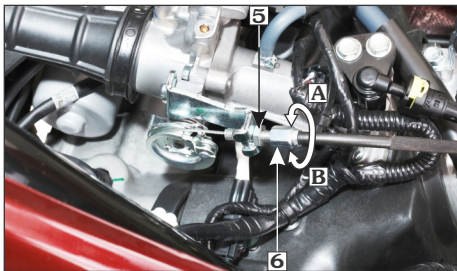

(5) Lock nut (6) Adjusting nut
(A) Decrease free play (B) Increase free play

AIR CLEANER DRAIN TUBE CLEANING

Refer to the safety precautions (page 67).

- Remove the drain tube (1) from the air cleaner assembly (2) and drain deposits in to a suitable container.
- Reinstall the drain tube.

Service more frequently when riding in rain, at full throttle or after the vehicle is washed or overturned. Service if the deposit level can be seen in the transparent section of the drain tube.

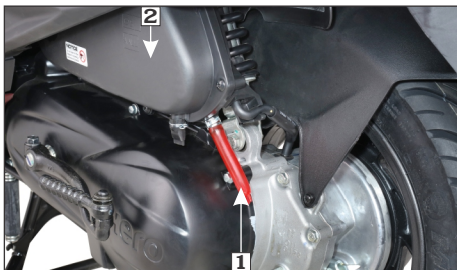

(1) Drain tube (2) Air cleaner assembly

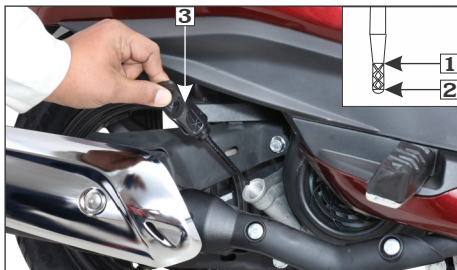

(1) Upper level mark (2) Lower level mark
(3) Oil level dipstick

ENGINE OIL

Use hero genuine engine oil or recommended grade oil.

BRAND : Hero 4T plus

**GRADE : SAE 10W 30 SL Grade
(JASO MB)**

Manufactured by:

- Tide Water Oil Co. (India) Ltd.
- Savita Oil Technologies Limited.
- Bharat Petroleum Corporation Limited.

Oil Capacity: 0.8 Litre

Engine oil level check

Check the engine oil level each day before riding the vehicle.

The level must be maintained between the upper (1) and lower (2) level marks on the oil level dipstick (3).

- Park the vehicle on its main stand on a level surface.

- Start the engine and let it idle for few minutes.
- Stop the engine and wait for few seconds.
- Remove the oil level dipstick, wipe it clean and reinsert the oil level dipstick without screwing it in.
- Remove the oil level dipstick and check if the oil level is between the upper and lower marks.
- If required, add recommended oil up to the upper level mark. Do not overfill.
- Reinstall the oil level dipstick with new O-ring. Check for oil leaks.



NOTE

- **Running the engine with insufficient oil may cause engine damage.**
- **Top up if required after every 3000 km.**

Engine oil replacement / Oil strainer cleaning

Change the engine oil with the engine at normal operating temperature and the vehicle on its main stand to assure complete and rapid draining.

- Remove the oil level dipstick.
- Place an oil drain pan under the crankcase and remove the oil drain bolt (1) and sealing washer (2).
- Remove the oil strainer screen cap (3).

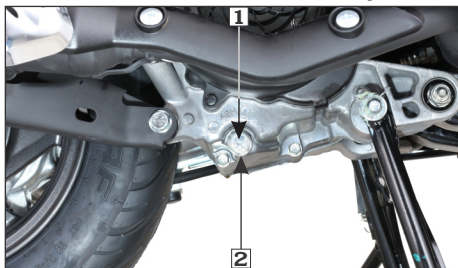

(1) Drain bolt

(2) Sealing washer

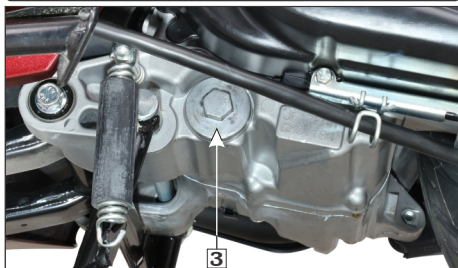

(3) Oil strainer screen cap

- The spring (4) and oil strainer screen (5) will come out when the oil strainer screen cap is removed.
- Clean the oil strainer screen.
- Check that the oil strainer screen, sealing rubber and cap O-ring (6) are in good condition.



(4) Spring (5) Oil strainer screen (6) O-ring

- Install the oil strainer screen, spring and oil strainer screen cap. Install the drain bolt with new sealing washer.
- Fill crankcase with the recommended grade of oil:

At draining: 0.70 litre

At engine disassembly: 0.80 litre

- Install the oil level dipstick.
- Start the engine and let it idle for 2-3 minutes. Stop the engine and ensure that the oil level is at the upper level mark on the oil level dipstick with the vehicle upright on flat level surface. Ensure there are no oil leaks.

! CAUTION

- **Engine oil quality is the chief factor affecting engine service life. Replace and top-up the engine oil as specified in the maintenance schedule (pages 68).**
- **When running in very dusty conditions, oil changes should be performed more frequently than specified in the maintenance schedule.**

! WARNING

- **Please dispose used engine oil in a manner that is compatible with the environment. We suggest you take it in a sealed container to your local recycling center or service station for reclamation. Do not throw it in the trash or pour it on the ground or down a drain.**
- **Used engine oil may cause skin disease if repeatedly left in contact with the skin for prolonged periods. Although this is unlikely unless you handle used oil on a daily basis, it is still advisable to thoroughly wash your hands with soap and water as soon as possible after handling used oil.**

FINAL DRIVE OIL REPLACEMENT

The final drive oil should be replaced as per the maintenance schedule. Replacement requires mechanical skill. It is suggested to get it replaced by Authorised Hero MotoCorp workshop.

- Park the vehicle on its main stand on a level surface.
- Start the engine and let it idle for 3-5 minutes.
- Stop the engine and wait for 2-3 minutes.

- Remove the oil level check bolt (1) with sealing washer (2)
- Remove the drain bolt (3) with sealing washer (4), slowly turn the rear wheel and drain the oil.

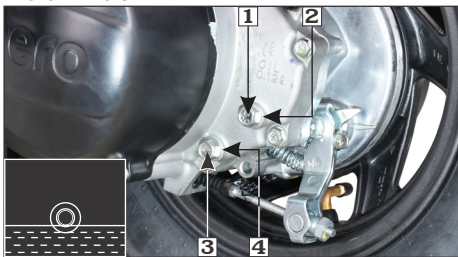

(1) Check bolt
(3) Drain bolt

(2) Sealing washer
(4) Sealing washer

- After the oil is completely drained, install the oil drain bolt with a new sealing washer.
- Fill the transmission case with recommended oil through the check bolt hole up to the bottom edge of the bolt hole.

**GRADE : SAE 10W 30 SL Grade
(JASO MB)**

At draining : 0.10 Litre

At transmission disassembly: 0.12 Litre

- Install the oil level check bolt with a new sealing washer and tighten it.

! WARNING

- **While refilling the oil make sure that no foreign material enters the final drive transmission.**
- **Make sure that no oil gets on the tyre or wheel.**

SPARK PLUG

Refer to the safety precautions (page 67).

Recommended spark plug.

Champion-**RG8YC** (Federal Mogul)

- Remove the center cover (page 48).
- Disconnect the noise suppressor cap (1) from the spark plug.
- Clean any dirt around the spark plug base.

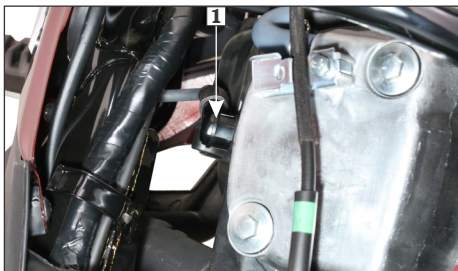

(1) Noise suppressor cap

- Remove the spark plug using the wrench plug provided in the tool kit.
- Inspect the electrodes and center porcelain for deposits, erosion or carbon fouling. If the erosion or deposit is heavy, replace the plug. Clean carbon or wet fouled plug with a plug cleaner.
- Check the spark plug gap using a wire-type feeler gauge. If adjustment is necessary, bend the side electrode (2) carefully.
- With the plug washer attached, thread the spark plug in by hand to prevent cross threading.

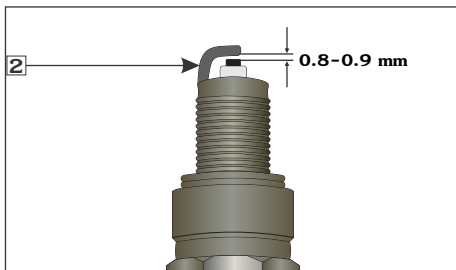

(2) Side electrode

- Tighten a new spark plug 1/2 turn with a wrench plug to compress the washer. If you are reusing a plug, it should only take 1/8-1/4 turn after the plug seats.
- Reinstall the noise suppressor cap.

WARNING

- **Never use a spark plug with an improper heat range. Severe engine damage could result.**
- **The spark plug must be securely tightened. An improperly tightened plug can become very hot and possibly damage the engine.**

BRAKE SHOE WEAR

Refer to the safety precautions (page 67).

The front/integrated brake and rear brake are equipped with brake wear indicators.

When the brake is applied, an arrow mark (1) on the brake arm (2) moves towards a reference mark (3) on the brake panel (4).

Front/Integrated brake

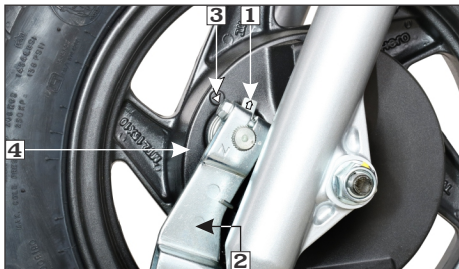

- (1) Arrow (2) Integrated brake arm
(3) Reference mark (4) Brake panel

Rear brake

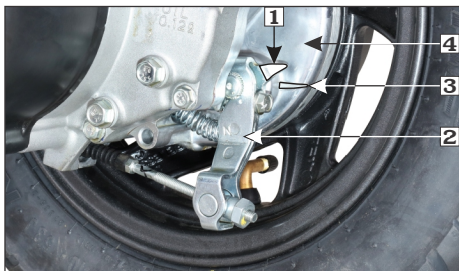

- (1) Arrow (2) Brake arm
(3) Reference mark (4) Brake panel

If the arrow aligns with the reference mark on full application of the brake, the brake shoes must be replaced. Visit your Authorised Hero MotoCorp workshop for this service.

BATTERY

Battery is located behind the front upper cover.

Specification

*MF Battery 12V-4Ah/ETZ5

It is not necessary to check the battery electrolyte level or add distilled water as the battery is of **Maintenance Free (sealed)** type. If your battery seems weak and/or electrolyte is leaking (causing hard starting or other electrical troubles), contact your Authorised Hero MotoCorp workshop.

NOTE



This symbol on the battery means that this product must not be treated as household waste.



This symbol on the battery means the old battery must be returned to your Authorised Hero MotoCorp workshop as it must be treated as recyclable material.

- **Battery is a Maintenance-Free (sealed) type and can be permanently damaged if the sealing strip is removed.**
- **An improperly disposed battery can be harmful to the environment and human health. Always confirm local regulations for battery disposal.**

*MF stands for Maintenance Free

Battery charging

Always visit your Authorised Hero Moto Corp workshop if you see any symptom of battery discharge as earliest as possible to get the battery charged. The battery has a tendency to discharge rapidly if any additional electrical accessories are fitted on your vehicle.

Battery storage

- If in case your vehicle is not used for more than a month remove the battery, fully charge and store in a cool and dry place.
- If the battery is expected to be stored for more than two months, ensure to fully charge the battery once in a month.
- Always ensure the battery is fully charged before installation.
- Ensure the battery leads are properly connected to the battery terminals during installation.

Battery removal

- Remove the front upper cover (**page 51**).
- Disconnect the (-)ve terminal lead (1) from the battery first, then disconnect the (+)ve terminal lead (2).

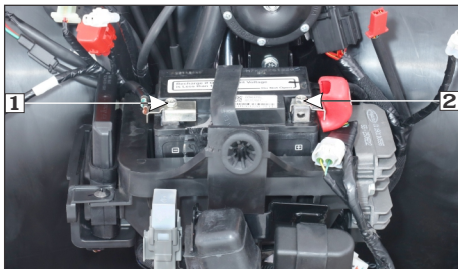

(1) (-)ve terminal (2) (+)ve terminal

- Remove the battery band (3) by removing the boot band clip (4) from both sides of the battery.

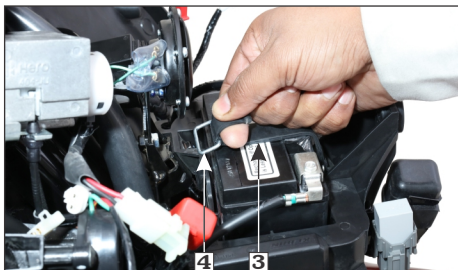

(3) Battery band (4) Boot band clip

- Remove the battery (5).



(5) Battery

Battery installation

- Reinstall in the reverse order of removal. Be sure to connect the (+)ve terminal first, then the (-)ve terminal.
- Check the bolts and other fasteners are secured.

FUSE REPLACEMENT

The fuse holder (1) placed adjacent to the battery which consist of main fuses and spare fuses.

Fuse type: Blade fuse

Main fuses (1) : 15A, 10A, 10A and 10A

Spare fuses (2) : 15A and 10A

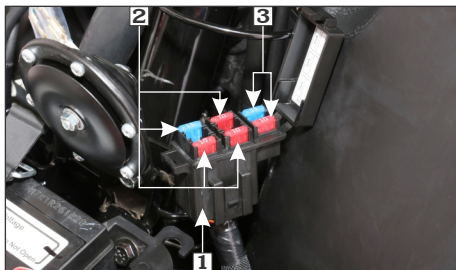

- (1) Fuse holder
- (2) Main fuses : 15A, 10A, 10A and 10A
- (3) Spare fuses : 15A and 10A

GOOD FUSE

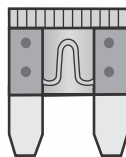

BLOWN FUSE

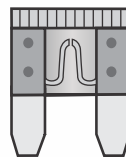

⚠ WARNING

- *Never use a fuse with a different rating from that specified. It may lead to serious damage to the electrical system or a fire due to short circuit.*
- *Battery gives off explosive gases. Keep sparks, flames & cigarettes away.*

! CAUTION

- *Do not attempt to start or ride the vehicle without a charged battery, it can cause fusing of the bulbs and permanent damage to certain electrical components.*
- *Turn the ignition switch "OFF" before checking or replacing the fuse to prevent accidental short-circuiting.*
- *If the replacement fuse of the same rating burns out in a short time, there is probably a serious electrical problem on your vehicle. Leave the blown fuse in that circuit and have your vehicle checked by your Authorised Hero MotoCorp workshop.*

SUSPENSION

Inspection

- Check the front forks by locking the front brake and pumping the front fork up and down vigorously. The suspension action should be smooth and there should be no oil leakage.



- Check the rear shock absorber by pushing hard downwards on rear grip while the vehicle is not parked on stand. The vehicle action should be smooth and there should be no oil leakage.

BULB/LED REPLACEMENT

Refer to the safety precautions (page 67).

The bulb becomes very hot while the lamp is "ON", and remains hot for a while after it is turned "OFF". Be sure to let it cool down before servicing.

Do not put finger prints on the headlamp bulb, as they may create hot spots on the bulb and cause it to break.

Wear clean gloves while replacing the bulb. If you touch the bulb with your bare hands, clean it with a cloth moistened with alcohol to prevent its early failure.

- Be sure to turn the ignition switch "OFF" when replacing the bulb.
- Do not use bulbs other than specified.
- After installing a new bulb, check that the lamp operates properly.

(a) Headlamp (VX & LX variant)

- Remove the headlamp assembly (page 53).
- Remove the screws (2) and remove the headlamp LED unit (3).

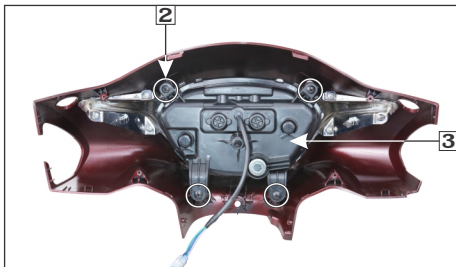

(2) Screws

(3) Headlamp LED unit

- Install a headlamp assembly in the reverse order of removal.

(b) Headlamp bulb (STD variant)

- Remove the headlamp assembly (**page 53**).
- Disconnect the headlamp connector (1).
- Remove the dust cover (2).
- Release the clip (3) from its position.
- Remove the headlamp bulb (4) without turning.

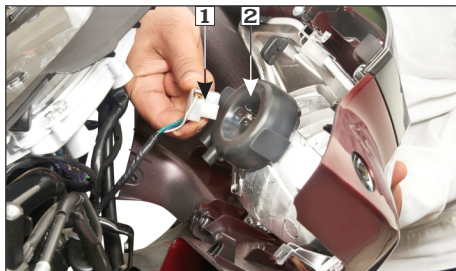

(1) Headlamp connector

(2) Dust cover

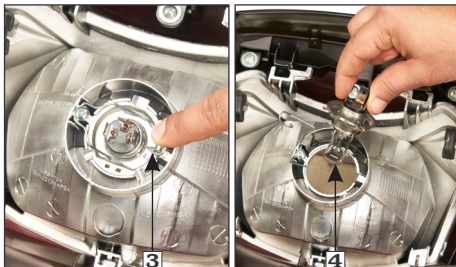

(3) Clip

(4) Headlamp bulb

- Install a new bulb in the reverse order of removal.
- Install the headlamp assembly (**page 54**).

(c) Front turn signal bulb

- Remove the front upper cover (**page 51**).
- Remove the bulb holder (1) with the bulb.
- Remove the bulb (2) by turning it to anticlockwise direction.



(1) Bulb holder

(2) Front turn signal bulb

- Install a new bulb in the reverse order of removal.
- Install the front upper cover (page 52).
- (d) Tail/Stop lamp bulb**
- Remove the body covers with tail/stop lamp assembly (page 49).
- Remove the holder (1) by turning it anticlockwise.
- Install a new tail/stop lamp bulb (2) in the reverse order of removal.
- Install the body covers with tail/stop lamp assembly (page 51).
- (e) Rear turn signal bulb**
- Remove the body covers with tail/stop lamp assembly (page 49).

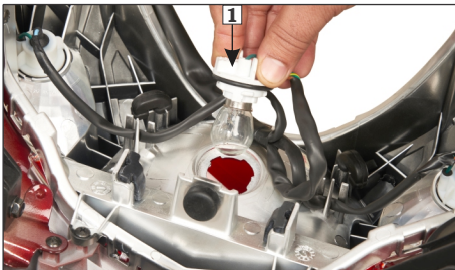

(1) Holder

- Remove the bulb (2) from bulb holder by turning anticlockwise.

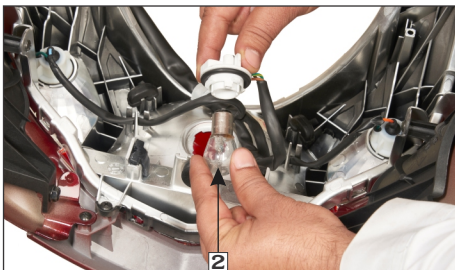

(2) Tail/stop lamp bulb

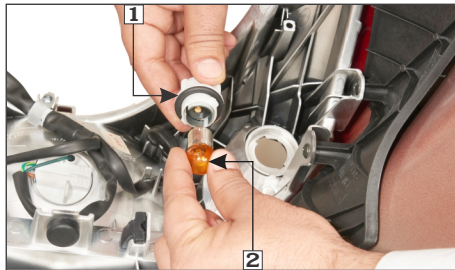

(1) Bulb holder (2) Rear turn signal bulb

- Remove turn signal bulb holder (1) by turning anticlockwise.
- Remove the rear turn signal bulb (2) by pressing it in and turning anticlockwise.
- Install a new bulb in the reverse order of removal.
- Install the body covers with tail/stop lamp assembly (page 51).
- (f) Licence plate lamp bulb**
- Remove licence plate lamp bulb holder (1) from the rear fender (2).

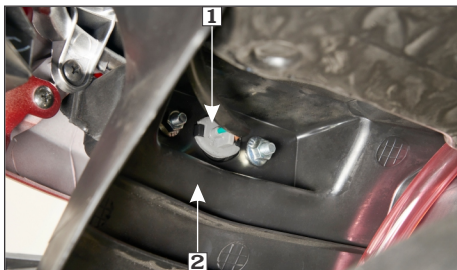

(1) Licence plate lamp bulb holder
(2) Rear fender

- Remove the licence plate lamp bulb (3) from the holder.

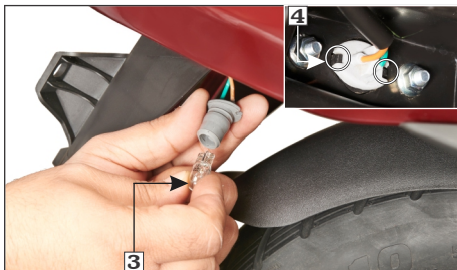

(3) Licence plate lamp bulb **(4) Slots/Tabs**

- Install a new bulb to the holder.
- Install the licence plate lamp bulb holder by aligning its slots with the tabs (4) on the rear fender.

CATALYTIC CONVERTER

This vehicle is equipped with the catalytic converters (1) in the muffler to meet the emission norms.

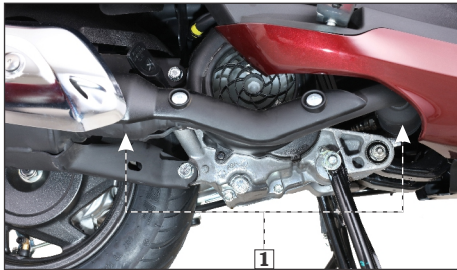

(1) Catalytic converters

The catalytic converters contains precious metals that serve as catalysts, promoting chemical reactions to convert the exhaust gasses without affecting the metals. The catalytic converters acts on HC, CO and NOx. The catalytic converters must operate at a high temperature for the chemical reactions to take place. It can set on fire any combustible material that come near it. Park your vehicle away from high grasses, dry leaves, or other flammable material.

A defective catalytic converter contributes to air pollution and can impair your engine's performance.

Follow these guidelines to protect your vehicle's catalytic converters.

- Always use unleaded petrol. Even a small amount of leaded petrol can contaminate the catalyst metals, making the catalytic converters ineffective.
- Keep the engine in good running condition. A poorly running engine can cause the catalytic converters to overheat.
- If your engine is misfiring, backfiring, stalling, or otherwise not running properly, stop riding and turn "OFF" the engine. Have your vehicle serviced as soon as possible.

EVAPORATIVE EMISSION CONTROL SYSTEM

This vehicle is equipped with an evaporative emission control system to meet emission standards. During warm weather, the petrol vapours which contain HC evaporates easily into the atmosphere from the fuel tank, if the fuel system is unsealed or open. The evaporative emission control system is used to prevent petrol vapours from escaping into the atmosphere from fuel tank. The canister (1) collects the fuel vapour from the fuel tank and then the fuel vapour is drawn into the engine for re-burning to avoid pollution caused by the fuel vapour diffused into the air.



(1) Canister

POLISHING OF VEHICLE

After washing your vehicle, wax all painted surfaces (except matte painted surfaces) using a commercially available polish/quality liquid or paste wax to finish the job. Use only a non abrasive polish or wax made specifically for automobiles. Apply the polish or wax according to the instructions on the container.



NOTE

Polishing or waxing is not applicable for models having matte finish paint.

REMOVING ROAD SALT

The road may contain salt which was sprayed as an anti freezing agent during winter, and the seawater are the causes of rust.

Wash your vehicle when run on such conditions by the following the point mentioned below, Clean the vehicle using cold water (**page 52**). Do not use warm water. This worsens the effect of the salt.

STORAGE GUIDE

Extended storage, such as for winter, requires that you take certain steps to reduce the effects of deterioration from non use of the vehicle. In addition, necessary repairs should be made before storing the vehicle, otherwise these repairs may be forgotten by the time the vehicle is removed from storage.

(a) Storage

- Change the engine oil.
- Empty the fuel tank into an approved petrol container using a commercially available hand siphon or an equivalent method.
- Spray the inside of the tank with an aerosol rust inhibiting oil.
- Reinstall the fuel filler cap on the tank.



WARNING

Petrol is highly flammable and explosive. You can be burned or seriously injured when handling fuel.

- ***Stop the engine and keep heat, sparks, and flame away.***
 - ***Refuel only outdoors.***
 - ***Wipe up spills immediately.***
- To prevent rusting in the cylinder, perform the following:
 - (a) Remove the noise suppressor cap from the spark plug. Using tape or string, secure the cap to any convenient plastic body part so that it is positioned away from the spark plug.
 - (b) Remove the spark plug from the engine and store it in a safe place. Do not connect the spark plug to the noise suppressor cap.

(c) Pour a tablespoon (15–20 ml) of clean engine oil into the cylinder, and cover the spark plug hole with a piece of cloth.

(d) Crank the engine several times to distribute the oil.

(e) Reinstall the spark plug and noise suppressor cap.

- Remove the battery. Store in an area protected from freezing temperatures and direct sunlight. Charge the battery once a month.
- Wash and dry the vehicle. Wax all painted surfaces. Coat chrome plated parts with rust inhibiting oil.
- Inflate the tyres to their recommended pressures. Park the vehicle on blocks to raise both tyres off the ground.
- Cover the vehicle (don't use plastic or other coated materials) and store in an unheated area, free of dampness with a minimum of daily temperature variation. Do not store the vehicle in direct sunlight.

(b) Removal from storage

- Uncover and clean the vehicle. Change the engine oil if the vehicle has been stored for more than 4 months.
- Check the battery voltage and charge the battery as required. Install the battery.
- Drain any excess aerosol rust inhibiting oil from the fuel tank. Fill the fuel tank with fresh petrol.
- Perform all pre-ride inspection checks (**page 54**). Test ride the vehicle at low speeds in a safe riding area away from traffic.

BASIC TROUBLESHOOTING

1. STARTING TROUBLE - ENGINE DOES NOT START

A. Fuel System

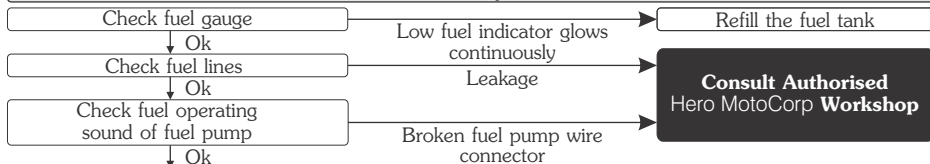

Consult Authorised Hero MotoCorp Workshop

B. Side Stand Engine Kill System (For vehicle equipped with side stand, which is optional)



Consult Authorised Hero MotoCorp Workshop

C. Electric Starter Not Working

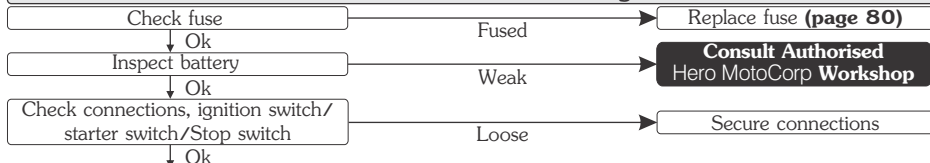

Consult Authorised Hero MotoCorp Workshop

D. No Spark At Spark Plug

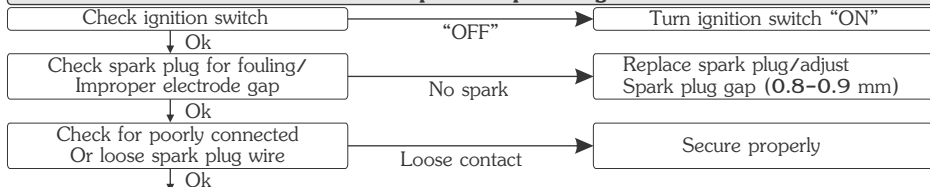

Consult Authorised Hero MotoCorp Workshop

BASIC TROUBLESHOOTING

2. ENGINE STARTS BUT STALLS



3. POOR PICK UP

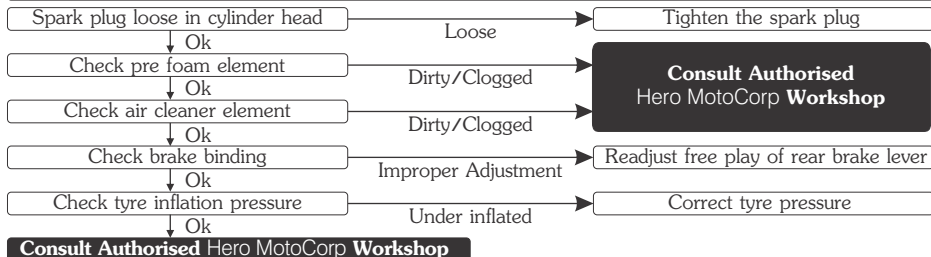

4. ELECTRICAL SYSTEM

Feeble horn sound or no light

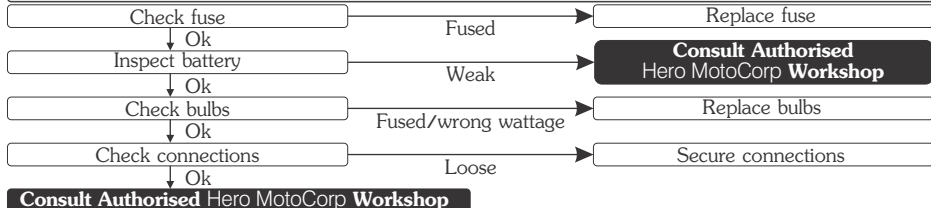

BASIC TROUBLESHOOTING

5. i3s SYSTEM

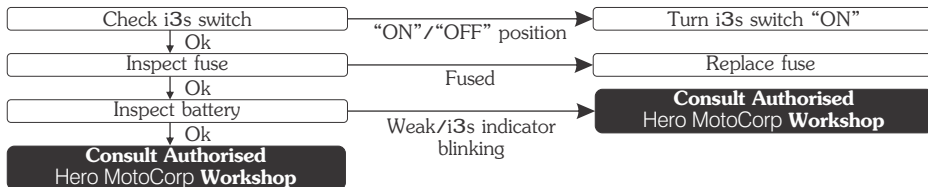

ROAD SIGNS



Mandatory signs: These road signs inform drivers/riders of the traffic rules that apply on a certain stretch of road, thereby instructing them on how to drive/ride. Mandatory signs are distinguished by the bright red circle with black and blue markings. It is imperative that all riders follow these signs as their help avoid accidents. Their violation can be penalised under the Motor Vehicle Act.

Mandatory

					
Stop	Give Way	One Way	No Horn	No Bicycles	No Automobiles
					
No Hand Craft	No Pedestrians	No Right Turn	No 'U' Turn	Overtaking Prohibited	Speed Limit
					
No Stopping or Standing	No Parking	Length Limit	High Limit	Restriction Ends	Compulsory-Ahead Only
					
Compulsory-Turn Left	Compulsory-Right Ahead	Compulsory-Ahead or Turn Right	Compulsory-Keep Left	Compulsory-Bicycle Track	Compulsory-Sound Horn

ROAD SIGNS



Cautionary signs: These signs inform the driver/rider of the road conditions ahead. Cautionary signs therefore serve as a warning. They are usually in a red triangle with black pictures on a white background. Illustrations, diagrams and symbols are used to forewarn about dangers ahead. Cautionary road signs are as important as mandatory signs. However, the violation of cautionary signs does not attract penalty.

Cautionary



Right Hand Curve



Right Reverse Bend



Incline Ahead



Narrow Road Ahead



Narrow Bridge



Pedestrian Crossing



School Ahead



Gap in Medium



Cross Road



Men at Work



Roundabout



Hump Road

ROAD SIGNS

Informatory signs: These are facility signs that provide important information about road directions are maps of specific destinations. On highways, they provide information about the location of public telephones, restaurants, hospitals, parking, petrol pumps, resting-places and more. These signs are usually rectangular, with black or white pictures on a blue background.

Informatory



Destination Sign



Hospital



First Aid Post



Petrol Pump



Eating Place



Resting Place



Public Telephone

Delhi

Place Identification Place



Light Refreshment



Taxi Stand



Parking Both Sides



Parking This Side



No Through Road



No Through Side Road

Bahadurgarh 10
Rohtak 48

Re-assure Sign

Signs and Signals are language of the road. Learn them, respect them.



DESTINI¹²⁵
XTEC

Hero MotoCorp Ltd.

WARRANTY

Scope of warranty

Hero MotoCorp Ltd. (hereinafter called 'Hero MotoCorp') warrants its **DESTINI 125 XTEC** vehicles, assembled/manufactured in its Plants and sold through its channel partners, to be free from any defect – both in material and workmanship, under normal use and conditions, subject to the following terms & conditions.

Terms & conditions

- a) **DESTINI 125 XTEC** vehicle is warranted for a period of **5 years or 50000 Km**, whichever is earlier, from the date of purchase, emission warranty is separately covered under the head of "Emission Warranty".
- b) It is advised that the purchaser avails all free and paid services from the Hero MotoCorp's authorized workshop as per the recommended schedule, to be eligible for warranty benefits. Each paid service should be availed within **90** days from the date of previous service or as per the recommended schedule, whichever is earlier.
- c) If any problem is observed in **DESTINI 125 XTEC** vehicle, Hero MotoCorp's only obligation/liability is to repair or replace that part/those parts which is/are considered to be the cause of such problem, provided however that such problem has not resulted due to misuse/improper handling etc. of the vehicle. Any **DESTINI 125 XTEC** vehicle needing repair should be brought along with owner's manual to Hero MotoCorp's authorized workshop for necessary inspection and carrying rectification job.



DESTINI¹²⁵
XTEC

Hero MotoCorp Ltd.

LIMITATIONS OF WARRANTY

The warranty shall not apply—

- (1) If all free services/paid services/oil top-ups are not availed as per the recommended schedule at Hero MotoCorp's authorized workshop.
- (2) If any other engine oil which is non compatible with product is used other than SAE 10W30 SL Grade (JASO MB).
- (3) To normal wear & tear components including (but not limited to) brake shoes, clutch shoes, drive belt, bulbs, electrical wiring, filter, spark plug, fasteners, shims, washers, oil seals, gaskets, rubber parts, bush, rubber bellows, plastic parts breakage, wheel rim for misalignment/bend, steering ball race & cone, control cables such as brake cable, fuses (all types), steering handle for bend and sticker peel off.
- (4) If additional wheel(s) is/are fitted and/or any other modification carried out/unauthorized accessories fitted which shall be responsible for malfunction/deterioration of the vehicle.
- (5) If **DESTINI 125 XTEC** vehicle has been used in any competitive events like races or rallies or for any commercial purposes as taxi etc.
- (6) To any damage on vehicle's painted surface cropping due to industrial pollution or other external factors.
- (7) For normal phenomena like noise, vibration, oil seepage etc., which do not affect the performance of the vehicle.
- (8) To any damage caused due to usage of improper oil/grease, non-genuine parts.
- (9) If any defect crops or repairs needed as a result of using adulterated fuel.
- (10) If any maintenance/repairs required due to bad road conditions or misuse of **DESTINI 125 XTEC** vehicle.
- (11) If any defect crops or repairs needed as a result of **DESTINI 125 XTEC** vehicle meeting to some accident.
- (12) For consumables like oil, grease, gasket etc to be used during free services and/or warranty repairs.
- (13) To any part of the **DESTINI 125 XTEC** vehicle which has been tampered or repaired in such a manner which has resulted in malfunction of the vehicle.
- (14) For **DESTINI 125 XTEC** vehicle not used in accordance with the guidelines given in this Owner's Manual.
- (15) To proprietary items like Tyres, Tubes, Batteries etc, as they are subjected to the warranty terms & conditions of respective manufacturers and directly handled by them only.
- (16) Any defect(s) developing on account of external factors such as environmental factors; including but not limited to fading/peeling/rusting of paint and/or stripes and/or plated parts, seat leather tearing & cracking, aluminium parts oxidation and cracking & discoloring of control switches etc.

Decision regarding warranty settlement shall be taken by Hero MotoCorp and the same shall be final and binding on all concern.

Subject to DELHI JURISDICTION only.



DESTINI¹²⁵
XTRAC

Hero MotoCorp Ltd.

BATTERY WARRANTY PERIOD

1. 18 months from date of sale of vehicle or 20000 km. or
2. 21 months from the date of charging (whichever is earlier).
3. 3 months idle period is allowed from the date of charging to date of sale on vehicle.

Terms and condition of warranty

1. Batteries are warranted against all defects in material and workmanship. Liability under this warranty is limited to making good of defects rising solely from the use of faulty material or workmanship during manufacturing and developing under proper use. The warranty commences from the date of delivery to the original purchase of the vehicle.
2. In the event of any complaint the battery is to be returned complete with electrolyte to nearest battery service station or any OEM dealer. On inspection, battery would be returned or replaced.
3. This warranty card accompanies a battery sold as OEM fitment only. Claims should be supported with vehicle purchase invoice to enable processing.
4. The right to determine whether a battery needs repair or totally replacement lies with the company. In case where the battery is replaced, the defective battery becomes the property of the company and no scrap rebate will be given for it. The warranty period on the battery being repaired/replaced shall commence from the date of sale of the original battery as stated in the original warranty card.
5. All liabilities under this warranty will cease if the battery is used on the vehicle other than that on which the battery was originally fitted and on the expiry of the warranty period as mentioned above.
6. Recharging is not covered under the purview of this warranty and shall be billed as extra. However, FOC battery replacement/repair includes cost of charging.
7. This warranty does not cover damage to the battery caused by faulty electrical systems, incorrect charging and filling, improper handling of the battery by unauthorized dealers/auto electricians, maintenance, willfull abuse, destruction by fire, collusion, theft or recharging.
8. Breackage of container and cover do not come under the purview of this warranty.
9. Adjudication and settlement of claim will take a couple of days as a battery has to be tested for the reported failure.
10. In case of tempering of the original wiring circuit in any manner whatsoever.
 11. If a battery which is not recommended is fitted on the vehicle then such battery will not carry any warranty.
 12. The applicable taxes which is leviable on the battery under repair or replacement will be borne by the customer.
 13. Customers are deemed to have read, understood and agreed to these conditions at the time of purchase of the vehicle.



DESTINI¹²⁵
XTRAC

Hero MotoCorp Ltd.

EMISSION WARRANTY

Scope of warranty

Hero MotoCorp Ltd. Warrants all its vehicles, assembled/manufactured at its various Plants and sold through its channel partners, to comply with emission standards as specified in sub rule (2) of Rule 115 of Central Motor Vehicles Rules, 1989, subject to following terms & conditions.

Terms & conditions

- a) The emission warranty shall be applicable in India and shall remain valid for a period of 3 years or 30000 km, whichever occurs earlier, from the date of vehicle purchase.
- b) In case any defect is observed in any emission-related component which are covered under emission warranty, Hero MotoCorp only obligation/liability shall be to repair and/or replace those part (s) which is/are considered to be the cause of non-compliance with the emission standards.
- c) The method (s) of examination to determine the warranty conditions of the emission warranty related component will be at the sole discretion of Hero MotoCorp Ltd. and / or Channel Partners / service center and result of such examination shall be final and binding. If on examination the warranty conditions of the part (s) is / are not established, Hero MotoCorp Ltd. will have the right to charge all, or part of the cost of such examination / service charges to the customer in addition to the cost of the components.
- d) Hero MotoCorp Ltd. shall have the sole discretion to decide to replace the defective components or the entire assembly or any other part required for such repair.
- e) The emission warranty shall be applicable only to those vehicles, which are being regularly maintained in accordance with the maintenance schedule provided in the owner's manual.
- f) The customer should follow the recommended parts replacement as per the maintenance schedule in order to avail the emission warranty.
- g) If any part (s) related to emission characteristics of the vehicles is/are tampered and/or repaired by unauthorized person/workshops etc, then the emission warranty shall stand cancelled.
- h) Any part (s) suffering wear and tear under the normal course of running shall not be covered under the emission warranty. Therefore, all such parts should be replaced by the customer from time to time, on payment basis, as per the maintenance schedule provided in owner's manual and dealer's advice
- i) It is recommended to avail the services as per the recommended schedule to be eligible for the emission warranty benefits. Please ensure that each paid service is availed within 90 days from the date of previous services or as per the recommended schedule, whichever is earlier. All service details should be completely filled by the dealer, in the **Service Record Sheet** given in the owner's manual.



DESTINI¹²⁵
X^{TRAC}

Hero MotoCorp Ltd.

EMISSION WARRANTY

- j) It is mandatory to obtain a PUC certificate from the Authorised PUC center. In case of non-compliance with the emission standards please contact the channel partner/authorised workshop immediately along with the previous OK certificate, for the necessary rectification. The manufacturer or the dealer is not responsible for any penalty levied on you on account of non-compliance with the emission standards.
- k) The parts, which are covered under emission warranty are fuel injector, fuel pump, throttle body, ignition coil, oxygen sensor and muffler.
- l) Emission warranty shall not be applicable if
- The vehicle has been subjected to abnormal use, abuse, neglect and improper maintenance or has met with an accident.
 - The vehicle, or parts thereof, has been altered, tampered with or modified or replaced in an unauthorized manner.
 - The odometer is not functioning or the odometer and/or its reading has been changed/tampered with, so that the actual distance covered cannot be readily determined.
 - The vehicle has been used for competitions, races, and rallies or for the purpose of establishing records.
- m) All decisions regarding emission warranty settlement shall be taken by Hero MotoCorp Ltd. and shall be final binding on all concerned.

Subject to Delhi jurisdiction only.



GENUINE PARTS

WHAT ARE THE BENEFITS OF Hero MotoCorp GENUINE SPARE PARTS ?

- Assures long life
- Ensures economy for a long time
- Safety of vehicle and rider
- Peace of mind
- Value for money
- Assured quality

CONSEQUENTIAL DAMAGES ON USING NON-GENUINE PARTS

Cam Chain Kit	<ul style="list-style-type: none">• Poor performance• Reduced life• Material used is inferior• Damages other parts of clutch like, clutch center and outer clutch
Gasket Cylinder Head	<ul style="list-style-type: none">• Improper sealing• Engine knocking• Leads to leakage and smoky exhaust• Higher emission level
Element Air Cleaner	<ul style="list-style-type: none">• Improper air filtration resulting in premature engine failure• Affects fuel efficiency• Poor engine performance
Spark Plug	<ul style="list-style-type: none">• Frequent stalling of engine• Higher emission level• Poor engine performance• Affects fuel efficiency
Brake Pads/Shoes	<ul style="list-style-type: none">• Poor braking efficiency• Rider safety-an issue• Discs/Drum wear out, resulting in subsequent repair cost

ZONAL/REGIONAL/AREA OFFICES

For any of your service related query/requirements you may contact the respective Zonal/Regional/Area Offices

CENTRAL ZONE

Hero MotoCorp Ltd., No. 208, 209, 210- 2nd floor, Ganpati Plaza, M.I. Road, Jaipur-302001, (Rajasthan).
Tel: +91 141-2389031, 2389156, 2389252, E-mail: jaipur@heromotocorp.com

Hero MotoCorp Ltd., Office No. 705-706, 7th Floor, Manglam Fun Square, Durga Nursery Road, Udaipur -313001 (Rajasthan). Tel: +91 0294-2980578, 79, E-mail: udaipur@heromotocorp.com

Hero MotoCorp Ltd., Office.No.401, 4th Floor, Offizo, Magneto Mall, Labhandi, G.E. Road, Raipur -492 001, (Chhattisgarh)
Tel: +91-771-4034749, E-mail: raipur@heromotocorp.com

Hero MotoCorp Ltd., Office No. 55 to 59, 1st Floor, Maple High Street, Opposite Aashima Mall, Hoshangabad Road, Bhopal-462026, India. Tel: +91-7000562763, E-mail: bhopal@heromotocorp.com

Hero MotoCorp Ltd., Maloo-01, 601-602, 6th Floor, Plot No. 26C, Scheme No. 94, Ring Road, Indore, M.P.-452010,
Tel: +91-731-4978269, 70, E-mail: indore@heromotocorp.com

EAST ZONE

Hero MotoCorp Ltd., Flat No: 1002, 10th Floor, Martin Burn Business Park, BP3, Salt Lake, Sector-V, Kolkata-700091, West Bengal, India. Tel : +91-33-44026841,+91-33-44026830, E-mail : kolkata@heromotocorp.com

Hero MotoCorp Ltd., Odysa Business Centre, Plot no. 30, 30/982, 172/1030, 4th Floor Cuttack, Bhubaneswar highway road, Rasulgarh, Bhubaneswar-751010, Odisha, India. Tel: +91-674-2581161, 62, 63, 64, E-mail: bhubaneswar@heromotocorp.com

Hero MotoCorp Ltd., Yash Heights, 1st Floor Bariatu Road, Above Basudeb Tata Showroom Ranchi-834009, Jharkhand, India. Tel: +91-651-2542222, 2542224, 2542225, E-mail: ranchi@heromotocorp.com

Hero MotoCorp Ltd., Sai Corporate Park, A Block, 6th Floor, Rukanpura, Bailey Road Patna, Bihar - 800014
Tel: +910612-2590587/88/89 E-mail: patna@heromotocorp.com

Hero MotoCorp Ltd., 158, Christian Basti, Golden Heights, 3rd Floor, Reliance Trend Building, Adjacent Central Mall, G.S. road, Kamrup, Assam-781005 Tel: 0361-2340058 E-mail: guwahati@heromotocorp.com

NORTH ZONE

Hero MotoCorp Ltd., 3rd Floor, Tower-A, DLF Centre Court, Sector-42, Golf Course Road, Gurgaon - 122002, Haryana, India. Tel: 0124-4754800, E-mail: delhi@heromotocorp.com

Hero MotoCorp Ltd., 602, 6th Floor, Tower A, Plot No BW 58, Logix City Center, Sector-32, Noida - 201301, Uttar Pradesh Tel: 0120-4631000, E-mail: noida@heromotocorp.com

Hero MotoCorp Ltd., S.C.O-367-368, First Floor, Sector-34A, Chandigarh- 160022, India.
Tel: +91-172-2623773, 2623774, 2623775, E-mail: chandigarh@heromotocorp.com

NORTH ZONE

Hero MotoCorp Ltd., Kapoor Towers, Plot No- 284, 15-B, Rajpur Road, Dehradun-248001, Uttarakhand, India.
Tel:0135-2714661,2713662,2714663, E-mail: dehradun@heromotocorp.com

Hero MotoCorp Ltd., Summit Building (10th Floor) Plot No TCG 3/3 Vibhuti Khand, Gomti Nagar Lucknow – 226010, India. Tel: 0522-4006594, E-mail: lucknow@heromotocorp.com

Hero MotoCorp Ltd., C-19/134-B ,Third Floor I.P Grand, Lallapura, Sagra, Varanasi, Uttar Pradesh - 221010, India.
Tel: +91-0542- 2390949,2390241, E-mail: varanasi@heromotocorp.com

SOUTH ZONE

Hero MotoCorp Ltd., SKAV 909, 3rd Floor, 9/1, Lavelle Road, Bangalore-560001, India.
Tel: +91-80-46881000, E-mail: bangalore@heromotocorp.com

Hero MotoCorp Ltd., 3-6-289, 3rd Floor, Kareem Manzil, Hyderguda, Hyderabad-500029, India.
Tel: +91-40-23223735/3727, E-mail: hyderabad@heromotocorp.com

Hero MotoCorp Ltd., 9th Floor Seshachalam Centre No.636/1. Anna Salai, Nandanam, Chennai-600035, India.
Tel: +91-44- 24340974, 24340977, 24340978, E-mail: chennai@heromotocorp.com

Hero MotoCorp Ltd., 6-A, DD Trade Tower, (6th Floor), Kaloor-Kadavanthra Road, Kaloor-682 017, Kochi-682017, India. Tel: +91-0484- 4039646 -7, E-mail: cochin@heromotocorp.com

Hero MotoCorp Ltd., No 1547, 2nd Floor Classic Towers, Trichy Road, Coimbatore - 641018
Tel: +91-422-2200058, 2200061, E-mail: coimbatore@heromotocorp.com

Hero MotoCorp Ltd., First Floor VA Kalburgi Mahalakshmi Mansion, Mandakini Hospital Road, New Cotton Market, Hubli-580029, India. Tel: 0836-2269717, 2361038, E-mail: hubli@heromotocorp.com

Hero MotoCorp Ltd., D.NO. 54-11-18 E, 2nd Floor, Sai Oddesey Building, Opp Executive Club, Near NH-5, Vijayawada-520008, Andhra Pradesh, India. Tel: +91-866-2546859, E-mail: vijayawada@heromotocorp.com

WEST ZONE

Hero MotoCorp Ltd., Chrome Building, Sr. No. 33, Hissa-A-1/1/2, Plot - 2, Viman Nagar Avenue 2, Nagar Road, Pune-411014, India. Tel: +91-020-71903500, E-mail: pune@heromotocorp.com

Hero MotoCorp Ltd., 604, Gunjan Tower, Off Alembic Gorwa Road, Baroda-390023, India.
Tel: +91-265-2286569/2286570, E-mail: baroda@heromotocorp.com

Hero MotoCorp Ltd., Ground Floor, Block No.2, Vishnu Vaibhav Complex, 222, Palm Road, Civil Lines, Nagpur-440001, India. Tel: +91-712-2545990-91, E-mail: nagpur@heromotocorp.com

Hero MotoCorp Ltd., Classic Stripes House, 3rd Floor 76/79, Makwana Lane, Takpada Off. Andheri-Kurla Road Marol, Andheri Easta, Mumbai-400059, India. Tel: +91-22-28562071, E-mail: mumbai@heromotocorp.com

Hero MotoCorp Ltd., B-201, 2nd floor, Pride Corporate Royal Park, Kalavad Road, Rajkot -360001
Tel: 0281-2460622, 2460623, E-mail: rajkot@heromotocorp.com