

# Operating Instructions



**RKP-4B, RKP-4**

**Professional Wireless  
Keypanel System**

**RTS™**



# Table of Contents

<b>Section 1 Introduction</b>	1-1
General Description	1-1
System Features	1-1
RKP-4B Block Diagram	1-3
RKP-4 Block Diagram	1-4
<b>Section 2 RKP-4B Base Station</b>	2-1
Controls and Connections - Front Panel	2-1
Controls and Connections - Rear Panel	2-2
<b>Section 3 RKP-4 Beltpack</b>	3-1
Controls and Connections - Top Panel	3-1
Controls and Connections - Rear Panel	3-2
<b>Section 4 Specifications</b>	4-1
RKP-4B Specifications	4-1
RKP-4 Specifications	4-2
<b>Section 5 Initial Equipment Set-Up</b>	5-1
Unpacking	5-1
Rack Mounting	5-2
Rack Mounting a Single Base Station	5-2
Rack Mounting Two Base Stations Side-by-Side	5-2
Antenna Connection	5-3
Antenna Polarization	5-3
Distance Between Antennas	5-3
Antenna Placement	5-3
<b>Section 6 RKP-4B (Base Station) Operation</b>	6-1
Basic Operational Description	6-1
System Quick Start	6-1
Interfacing to the RKP-4B	6-3
TX/RX Antennas	6-3
Matrix Port	6-2
Auxiliary Port	6-2
CAN Bus	6-3
Relay	6-3
Local Headset	6-4
Powering the Base Station	6-4
Start-up	6-5
Status Screen	6-5
Encryption Code	6-5
System Settings	6-6
Name and Number	6-6
Base Main Settings	6-6
Auxiliary Line	6-6
Base TX Power	6-6
Sidetone Levels	6-6
Frequency Settings	6-7
Matrix Settings	6-8
Four Wire Settings	6-8
RF Meter	6-8
ClearScan™	6-9
Special Button Functions	6-9

## Table of Contents (continued)

<b>Section 7 RKP-4 Operation</b> .....	7-1
Basic Operational Description .....	7-1
System Quick Start .....	7-1
Battery Installation .....	7-2
Headset Connection .....	7-3
Sidetone .....	7-3
Antenna Connections .....	7-3
RKP-4 Top Panel .....	7-4
On/Off Volume Control .....	7-4
Intercom Buttons .....	7-4
Copy and Scroll Keys .....	7-4
Call Waiting Display .....	7-4
Relay push button .....	7-4
Group and Channels .....	7-5
Transmit Frequency .....	7-5
Receiver Frequency .....	7-6
Battery Display .....	7-6
Microphone Gain .....	7-7
Transmit Power .....	7-7
Dark Operation .....	7-7
Encryption Code .....	7-7
Serial Number Code .....	7-8
Auto Programming .....	7-8
Software/Channel Map Version .....	7-8
ClearScan .....	7-8
Factory Reset .....	7-9
1st Use .....	7-9
Lock Out .....	7-9
<b>Section 8 Operation with a Matrix</b> .....	8-1
Start-up and Operational Check .....	8-1
Assigning Intercom Keys .....	8-1
Clearing Key Assignment .....	8-2
Charging Setup Pages .....	8-2
Momentary vs. Latching Operation .....	8-2
Intercom Key Operation for Different Types of Key Assignments .....	8-2
Intercom Key Indications .....	8-2
Call Waiting Operation for Incoming Calls .....	8-3
Displaying Key Assignments .....	8-3
Quick List of Matrix Key Functions .....	8-3
<b>Section 9 RKP-4 Menu Structure</b> .....	9-1
<b>Section 10 RKP-4B Menu Structure</b> .....	10-1
<b>Section 11 Frequency Bands</b> .....	11-1
<b>Section 12 Trouble Shooting</b> .....	12-1
<b>Section 13 Battery Information</b> .....	13-1
<b>Section 14 RKP-4B to Matrix Cable</b> .....	14-1
<b>Section 15 FCC Information</b> .....	15-1
<b>Section 16 Software License</b> .....	16-1
<b>Section 17 Accessories and Replacement Parts</b> .....	17-1

### General Description

The RTS RKP-4 UHF wireless keypanel system is the ultimate in reliable, high performance, encrypted full duplex communications.

The RKP-4 system includes the RKP-4B frequency agile base station and a RKP-4 frequency agile beltpack.

The RKP-4 system is ideal for users who want the freedom of a wireless keypanel and want full access to the most commonly used keypanel features. It is for those who generally communicate with four or less locations in the intercom system at any given time.

The RKP-4 systems has been designed for reliable, efficient operation. Operating in the 482 to 746 MHz range. The unit has expansion ability to add dozens of base stations to create a system. The high-efficiency beltpack provides up to 10 hours of uninterrupted operation using standard alkaline batteries.

### System Features

- Frequency agile base station and beltpacks.
- No external computer/device required to select frequencies or set parameters.
- Telex Communications proprietary digitally encrypted wireless communication between the base station and belt pack.
- AC or DC operation in the 12 to 15 Volt range.
- Backlit base station LCD allows the user to easily monitor the beltpack's status.
- The frequencies of a beltpack may be changed at the belt-pack or from the base station.
- Beltpack units contained in a weather and shock resistant die cast magnesium case.
- 4-wire, balanced audio input and output.
- Compatible with Adam™, Adam™ CS, Cronus™, and Zeus™ Digital Matrix Intercom Systems.
- Relay contact closure on the base station that can be activated from the beltpack. A GPI instruction can also be sent to the matrix.
- ClearScan™ function to automatically find the best channels on which to operate.
- Base stations are table or rack mountable.
- Alphanumeric call waiting display.
- Auxiliary balanced audio input and output.
- Full-function intercom keys with LED indicators.

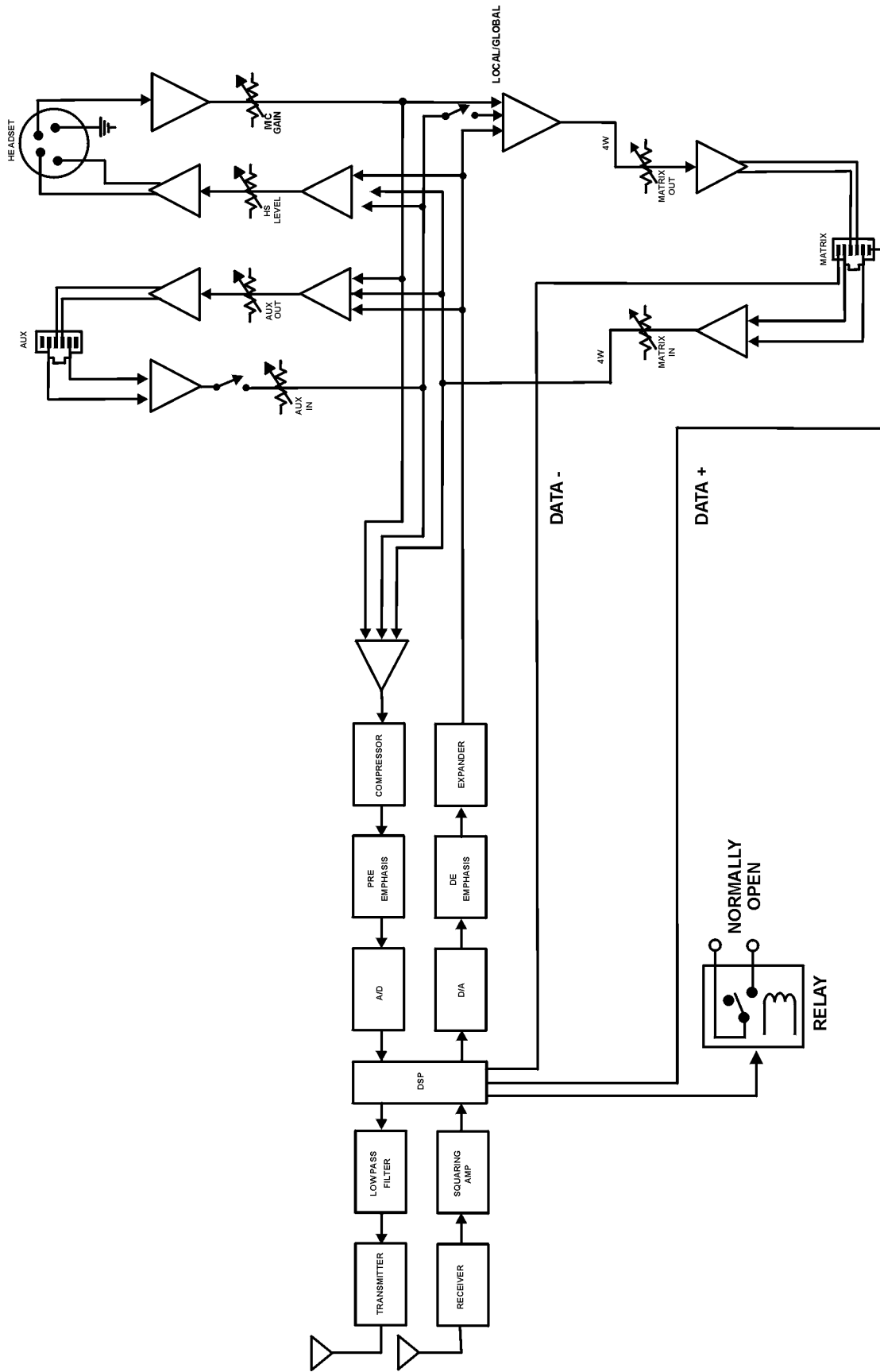

Figure 1-1  
RKP-4B -Block Diagram

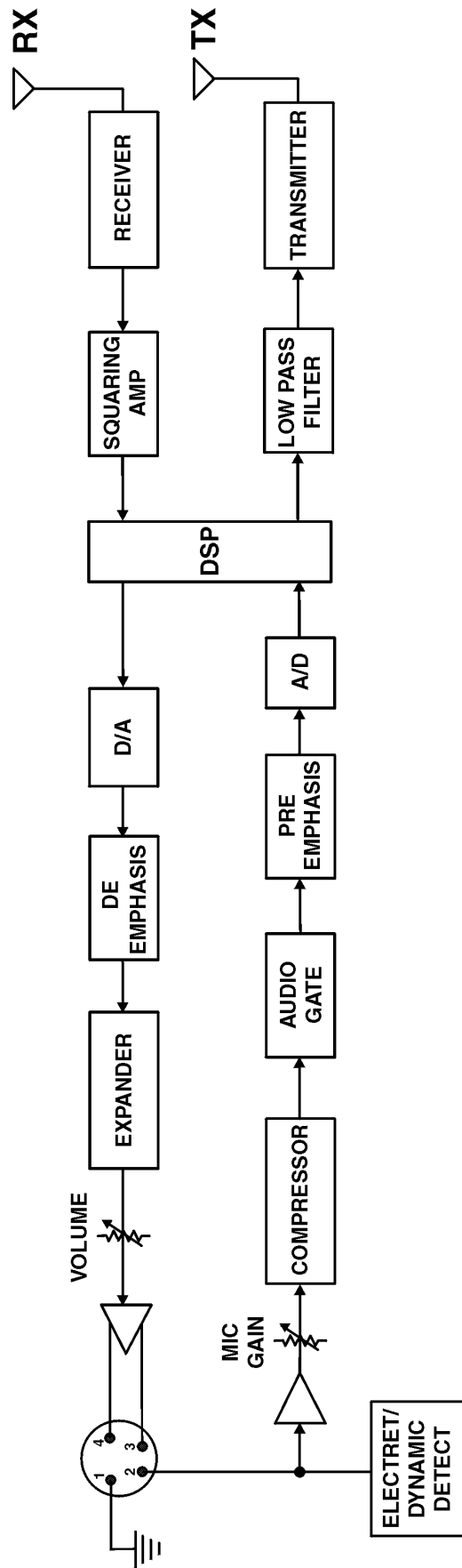

Figure 1-2  
RKP-4 Block Diagram





# Section 2

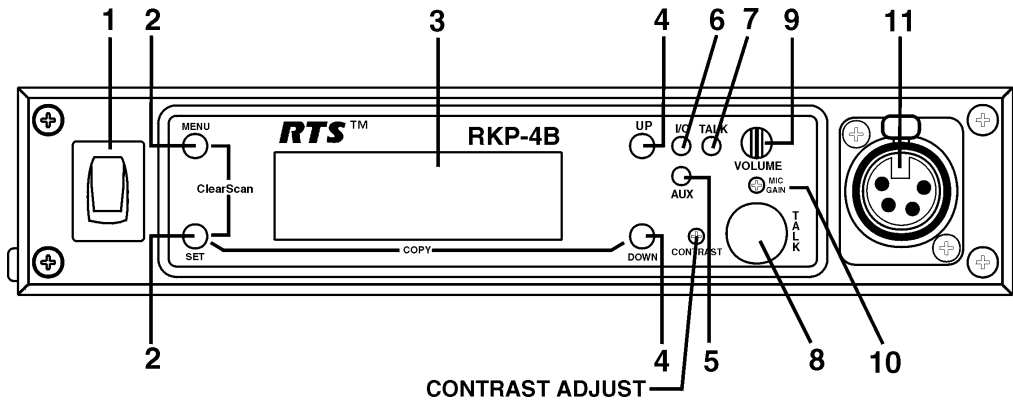

Figure 2-1  
RKP-4B -Front Panel

1. **On/Off Switch:** Turns the base station on/off
2. **[Menu] and [Set] buttons:** Used to select menus and set options on the LCD.
3. **Backlit LCD w/Contrast Adjust:** Adjust the level of contrast to the LCD.
4. **[Up] and [Down] buttons:** Used to select menus and set options on the LCD.
5. **Peak Aux Level Light:** Will flash red when the auxiliary input level into the base station is high.
6. **Peak Matrix Level Light:** Will flash red when the intercom input levels into the base station are high.
7. **Talk Light:** Green when the talk button is active. Will turn red when the microphone level into the local headset is high.
8. **Talk Button:** Press to enable the audio path from the headset.
9. **Headset Volume:** Used to adjust the volume level out to a headphone.
10. **Microphone Gain:** Adjusts the audio gain from the local headset microphone.
11. **Local Headset Connector:** Female XLR connector. A dynamic or electret headset microphone is automatically detected.

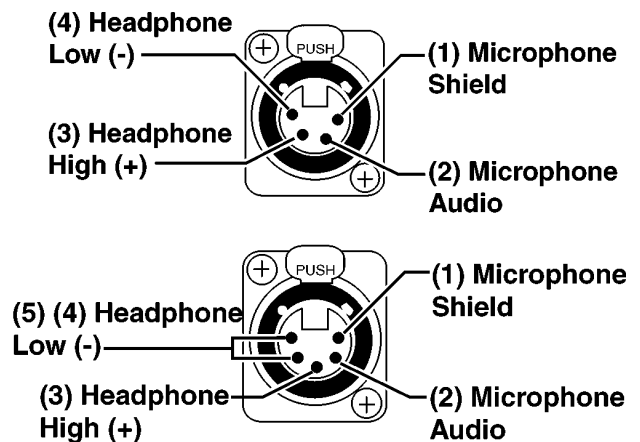

Figure 2-2  
Local Headset Wiring

## Controls and Connections - Rear Panel

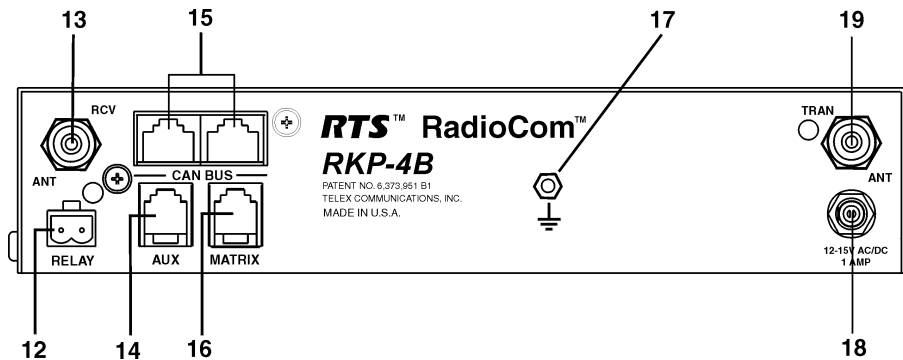

Figure 2-3  
RKP-4B - Rear Panel

- 12. **Relay Contacts:** Normally Open. When activated it will close.
- 13. **Receive Antenna Connector:** TNC Female connector. The color dot near the connector must match the color of the antenna.
- 14. **Auxiliary Connector:** RJ-12 connector used to connect balanced auxiliary audio into and out of a base station.
- 15. **CAN Bus:** RJ-45 connectors used to connect a base station to a CAN type of communications bus.
- 16. **Matrix Connector:** RJ-12 connector used to connect balanced 4-W audio into and out of the base station.
- 17. **Ground Lug:** Allows customer the option to ground the unit to a common system ground if needed.
- 18. **Power Connector:** Input power jack that requires 12 to 15 Volts AC or DC at 1000 mA.
- 19. **Transmit Antenna Connector:** TNC Female con-connector. The color dot near the connector must match the color of the antenna.

# Section 3

## RKP-4 Beltpack

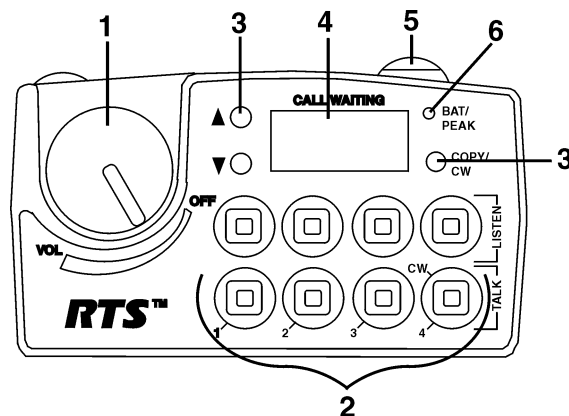

Figure 3-1  
RKP-4 Top Panel

### Controls and Connections - Top Panel

- On/Off & Volume Control:** Turns the beltpack power on and controls headset volume.
- Intercom Buttons:** Assignable for several types of operation, including talk only, listen only, talk with auto-listen, and all-call (where activating the key also activates all keys to the left of that key). Keys feature momentary or latching operation. For momentary operation, the operator presses and holds a key while communicating, then releases it when finished. For latching operation, the operator taps a key to turn it on, then taps it again to turn it off. Latching can be disabled via software options in the base station or from AZedit. Two bi-color (red and green) LED indicators for each key provide indications for talk on/off, listen on/off, incoming call, busy (for keys assigned to talk to IFB's), and in-use (for keys assigned to talk to either IFB's or ISO's).
- Copy and Scroll keys:** Used for key and setup page assignment. Can also be used to talk to any location in the intercom system when no intercom key is assigned. (Note: There are 4 setup pages. Each contains a complete set of key assignments.)
- Call Waiting Display:** 4-character, alphanumeric display for incoming caller names.
- Relay push button:** A momentary or latching (set via beltpack software) push button for activating the relay contact closure on the rear of the base station.
- Bat/O.M. Light**

Battery	Light flashes on power up	= Battery OK
	Light on continuously	= Battery Low
	Light does not flash or come on	= Battery Dead
Overmodulation	Light flashes on loudest speech	= Gain OK
	Light flashes on all speech	= Gain too high
	Light never flashes on loudest speech	= Gain too Low

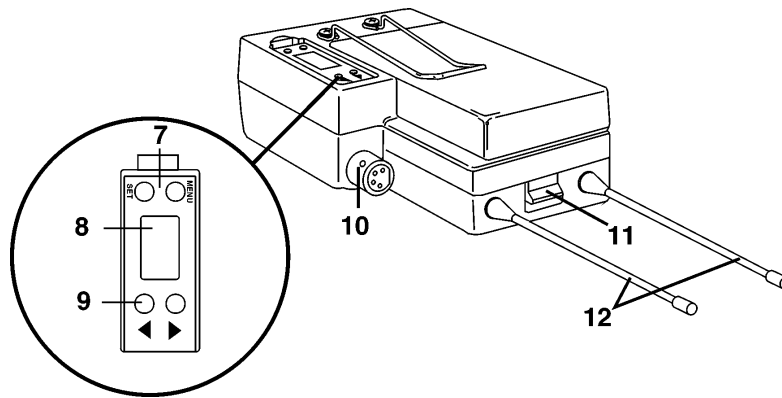

Figure 3-2  
RKP-4 Rear Panel/Connector/Antennas

7. **[MENU] and [SET] buttons:** Used to select menus and set options on the LCD.
8. **LCD (Liquid Crystal Display)**
9. **[UP] and [DOWN] buttons:** Used to select beltpack options on the LCD.
10. **Headset Connector:** Female XLR connector. A dynamic or electret headset microphone is automatically detected.
11. **Battery Latch:** Press down to enable the battery pack to be released. While the latch is held down, slide the battery pack about 1/8 inch back, toward the latch, until it stops, then lift out.
12. **Receive and Transmit Antennas:** The antennas are screw type, 1/4 wave, replaceable antennas. The color dot on the screw end of the antenna must match color dot on antenna receptacle.

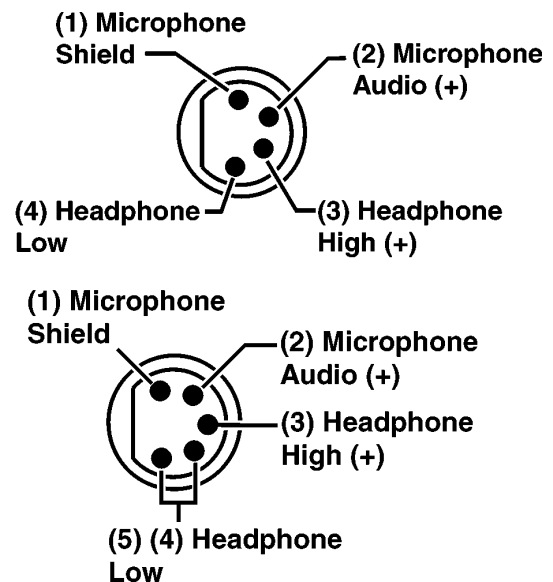

Figure 3-3  
Headset Jack Wiring

## RKP-4B Specifications

### *Overall*

RF Frequency Range	.482 - 608 MHz, 614 - 746 MHz in 18 MHz TX and RX bands
Power Requirements	.12-15 Volts AC/DC @ 1 Amp
Temperature Range	.-4 <sup>0</sup> F to 130 <sup>0</sup> F (-20 <sup>0</sup> C to 55 <sup>0</sup> C)
Dimensions	.8.25" W x 1.72" H x 9.00" D (20.9 cm x 4.4 cm cm)
Weight	.3 lbs 8 oz (1.59 kg)
TX Antenna	.1/2 Wave (supplied), TNC Male Connector
RX Antenna	.1/2 Wave (supplied), TNC Male Connector
FCC ID:	.B5DM519
Frequency Response	.100Hz-4.0kHz
Four Wire Input	.Level Adjustable (2 Vrms typical)
Four Wire Output	.Level Adjustable (2 Vrms typical)
Auxiliary Input	.Level Adjustable (2 Vrms typical)
Auxiliary Output	.Level Adjustable (2Vrms typical into 600 Ohms)
Microphone input sensitivity	.10 m V (200 Ohm Source)
Local Headset Output	.200 mW output into 150 Ohm (1% Distortion)

### *Transmitter*

Type	.Synthesized Transmitter, 720 channels
Transmit Power	.50mW typical (High), 5 mW typical (Normal)
Modulation Type	.GMSK
Deviation	.Complies with FCC 74.861
RF Frequency Stability	.0.005%
Radiated Harmonics & Spurious	.Exceeds FCC specifications

### *Receiver*

Type	.Dual Conversion Superheterodyne, 720 channels each
RF Sensitivity	.<0.8 $\mu$ V for 12 dB SINAD
IF Selectivity	.3 dB at 230 kHz
Image Rejection	.70 dB or better
RF Frequency Stability	.0.005%
Distortion	.<1% at peak level
S/N Ratio out to Matrix port	.80 dB (30kHz Low Pass Filtered)

## **RKP-4 Specifications**

### ***Overall***

RF Frequency Range	482 - 608 MHz, 614-746 MHz in 18 MHz TX and RX bands
Power Requirements	6 "AA" Cells Alkaline (NiMH optional)
Current Draw	190 mA (Typical)
Temperature Range	-4° F to 130° F (-20° C to 55° C)
Dimensions	3.75" W x 5.35" H x 2.02" D (9.5 cm x 13.5 cm x 5.1 cm)
Weight	.21 oz (545 g) with alkaline batteries
TX Antenna	1/4 Wave (supplied), Screw type, Replaceable
RX Antenna	1/4 Wave (supplied), Screw type, Replaceable
FCC ID:	B5DM523
Frequency Response	100Hz-4.0kHz
Microphone input sensitivity	.7 m V (200 Ohm Source)
Local Headset Output	.200 mW output into 150 Ohm (1% Distortion)

### ***Transmitter***

Type	Synthesized, 720 channels
Transmit Power	.50 mW typical (High), 5 mW typical (Low), or auto-power switching
Modulation Type	GMSK
Deviation	Complies with FCC 74.861
RF Frequency Stability	.0005%
Radiated Harmonics & Spurious	Meets or exceeds FCC specifications

### ***Receiver***

Type	Dual Conversion Superheterodyne, 720 channels
RF Sensitivity	<0.8 $\mu$ V for 12 dB SINAD
IF Selectivity	.3 dB at 230 kHz
Image Rejection	.70 dB or better
RF Frequency Stability	.0005%
Distortion	<1% at peak level
S/N Ratio out to Matrix port	.80 dB (30kHz Low Pass Filtered)

# Section 5

## Initial Equipment Set-Up

### Unpacking

Unpack your RKP-4 system. Below are the items that should come with our base station and each belt pack. Contact the shipper or your dealer immediately if anything is damaged or missing.

#### RKP-4B

Quantity	Description
1	RKP-4 Base Station
1	Operating Instructions (CD-ROM)
1	In-Line Power Supply
2	Antennas (one Transmit, one Receive)
1	Limited Warranty Sheet
4	Rubber Feet
1	Gain Adjust Plastic Screwdriver
1	Two Terminal Plug (for Relay)
2	Large Phillips Pan head Screw for Rack Mounting
2	Small Phillips Flathead Screw for rack Mounting
1	Single Unit Rack Mount Bracket
1	Dual Units (Side by Side) Middle Rack Mount Bracket
1	Rack Mount side Bracket

#### RKP-4

Quantity	Description
1	RKP-4 Beltpack with Antennas
1	Instruction Sheet
1	Battery Pack
1	Limited Warranty Sheet

## Rack Mounting

The rack mounting brackets come with each RKP-4. These brackets may be used to mount a single base station in a 19" wide rack or mount two base stations side by side in a rack. Figure 5-1 shows the three brackets that come with a base station.

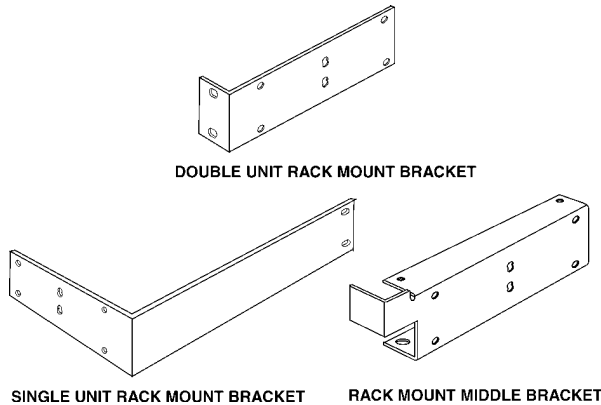

Figure 5-1  
Rack Mount Brackets

## Rack Mounting a Single Base Station

1. Remove the four pan head screws (two on each side) closest to the front panel.
2. Place the double unit side bracket on the side of the base station you wish closest to the edge of the rack.
3. Replace the two pan head screws and use a third pan head screw (2 supplied with base station) to screw into the upper middle location of the bracket.
4. Place the single unit rack mount bracket on the other side of the base station.
5. Replace the two pan head screws and the other pan head screw that came with the base to secure the bracket. Screw the third screw into the upper middle hole of the bracket.
6. Use the rack mount screws (not supplied) to secure the unit to the rack.

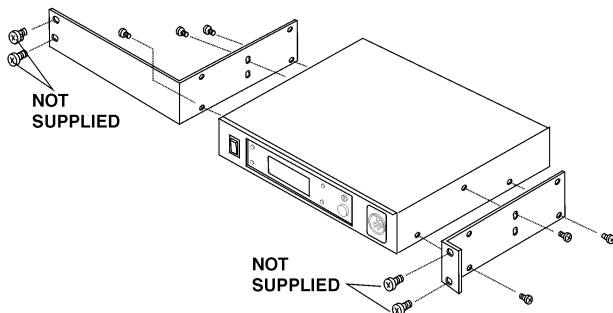

Figure 5-2  
Rack Mounting of a Single Unit

## Rack Mounting Two Base Stations Side-by-Side

1. Remove the four pan head screws (two on each side) closest to the front panel.
2. Place the double unit side brackets on the sides of the base stations you wish closest to the edge of the rack.
3. Replace the two pan head screws and use a third pan head screw (2 supplied with base station) to screw into the upper middle location of the rack mount middle bracket.
4. Place the dual bracket on the other sides of the base stations. Make sure the bracket is flipped so the front bend is toward the front of the base station. As you face the rack, the right base station will have the middle bracket front bend high and left base station will have the bend low.
5. Replace the two pan head screws and the other pan head screw into the upper middle hole of each bracket.
6. Use the four flat head screws (2 supplied with base station) to secure the top and bottom of the middle brackets together.
7. Use rack mount screws (not supplied) to secure the unit to the rack.

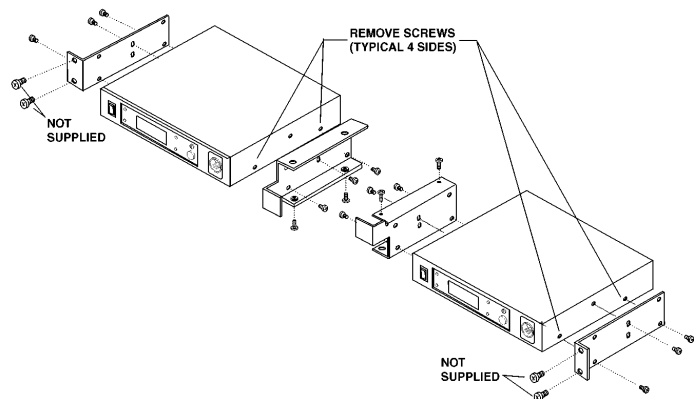

Figure 5-3  
Rack Mounting Two Base Units Side-by-Side



## Antenna Connection

The base station is supplied with two (2) antennas.

One 1/2-wave antenna for Transmit and one 1/2-wave for Receive. The antennas have TNC male connectors.

The frequency range of the antennas should match the receiver and transmitter of the base station. Match the color code on the antenna with the color code on the base station.

Attach the transmit 1/2-wave antenna to the antenna input receptacle labeled “TRAN” on the right side of the rear panel. The antenna should be vertically aligned.

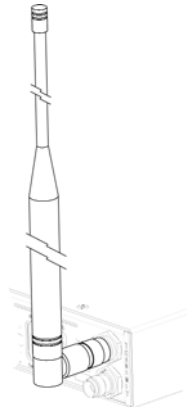

Figure 5-4  
Attaching Transmit 1/2-Wave Antenna

Attach the receive 1/2-wave antenna to the antenna input receptacle labeled “RCV” on the left side of the rear panel. The antenna should be vertically aligned.

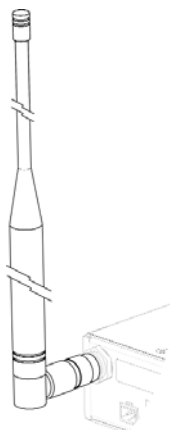

Figure 5-5  
Attaching Receive 1/2-Wave Antenna

## Antenna Polarization

The Telex Wireless Intercom System is “Vertically Polarized”. This means both the transmitting and receiving antennas should operate in the vertical position.

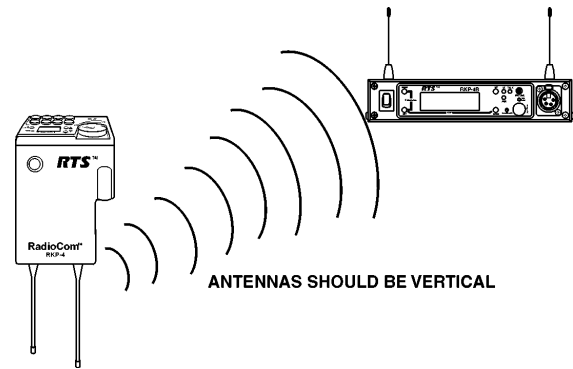

Figure 5-6  
Vertically Polarized Antennas

## Distance between Antennas

The distance between the base station’s receive and transmit antennas is not adjustable when the antennas are connected directly on the back of the unit.

The antennas can be removed for better signal path. A Telex coax assembly with remote antennas may be required. See “Accessory and Replacement Parts” section for ordering information.

**NOTE:** If your base station is to be located in a shielded rack mount enclosure or other poor RF location, you must remove the 1/2-wave antennas with coax assemblies. See “Accessories and Replacement Parts” section for remote mounting hardware.

## Antenna Placement

Proper antenna placement probably has the most effect on your TELEX Wireless Intercom System’s overall performance. The following suggestions will result in optimum performance.

Proper placement of the belt pack can be critical. The antennas should be in the open. Bending the antennas up and placing the belt pack in a pocket, etc., will reduce system distance.

It is suggested that the unit be worn on the belt with both antenna’s vertical for best operating range and performance.

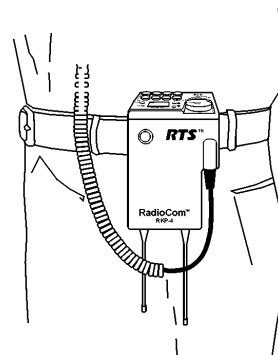

Figure 5-7  
Proper Dressing of the Antennas

Keep the distance between the base station and the belt packs as short as possible. The greater the distance, the weaker the signal. Make sure the “signal paths” between the base station and belt packs are unobstructed. You should be able to visibly locate the base station antennas at all times for best performance.

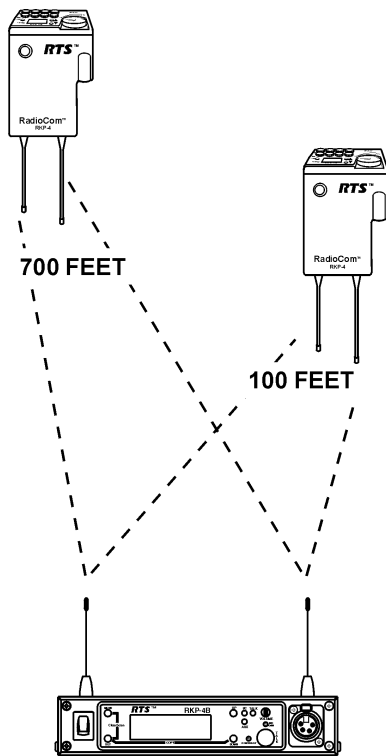

Figure 5-8  
Distance Between base station and belt pack

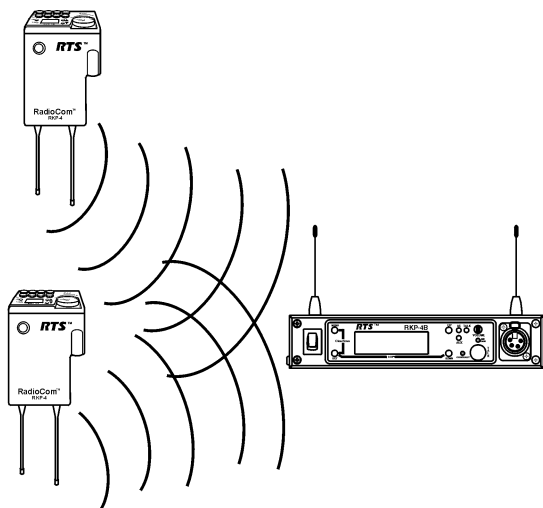

Figure 5-9  
Keeping Site Clear to Antennas

Attempting to operate the wireless intercom system through or around walls, ceilings, metal objects, etc. will reduce system range and performance.

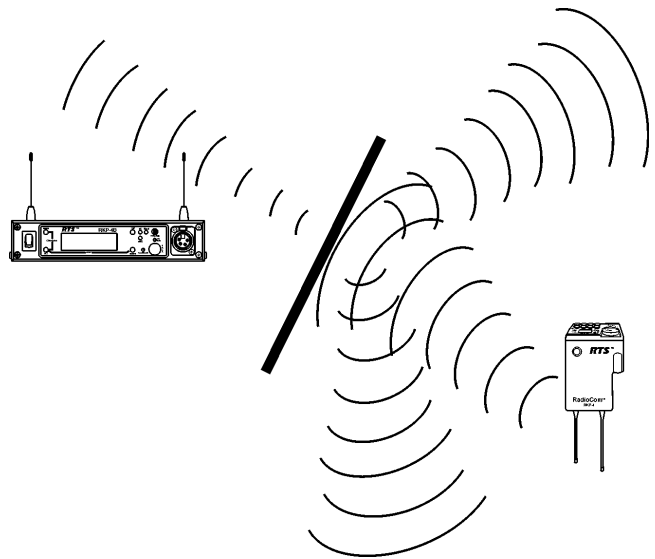

Figure 5-10  
Operating System Near Obstructions

**DO NOT** - mount the base station 1/2-wave antennas on, or next to metal, such as beams, walls with metal studs, equipment racks, etc. This also applies to the antennas when assembled directly to the Base Station. This will “detune” the antennas which can result in noise or loss of RF signal at the base station.

Keeping the distance from the base station and belt pack as short, and unobstructed as possible will produce the most reliable performance.

The base station is supplied with two antennas. This should provide satisfactory system performance in most applications. System range can be enhanced by removing the 1/2-wave antennas.

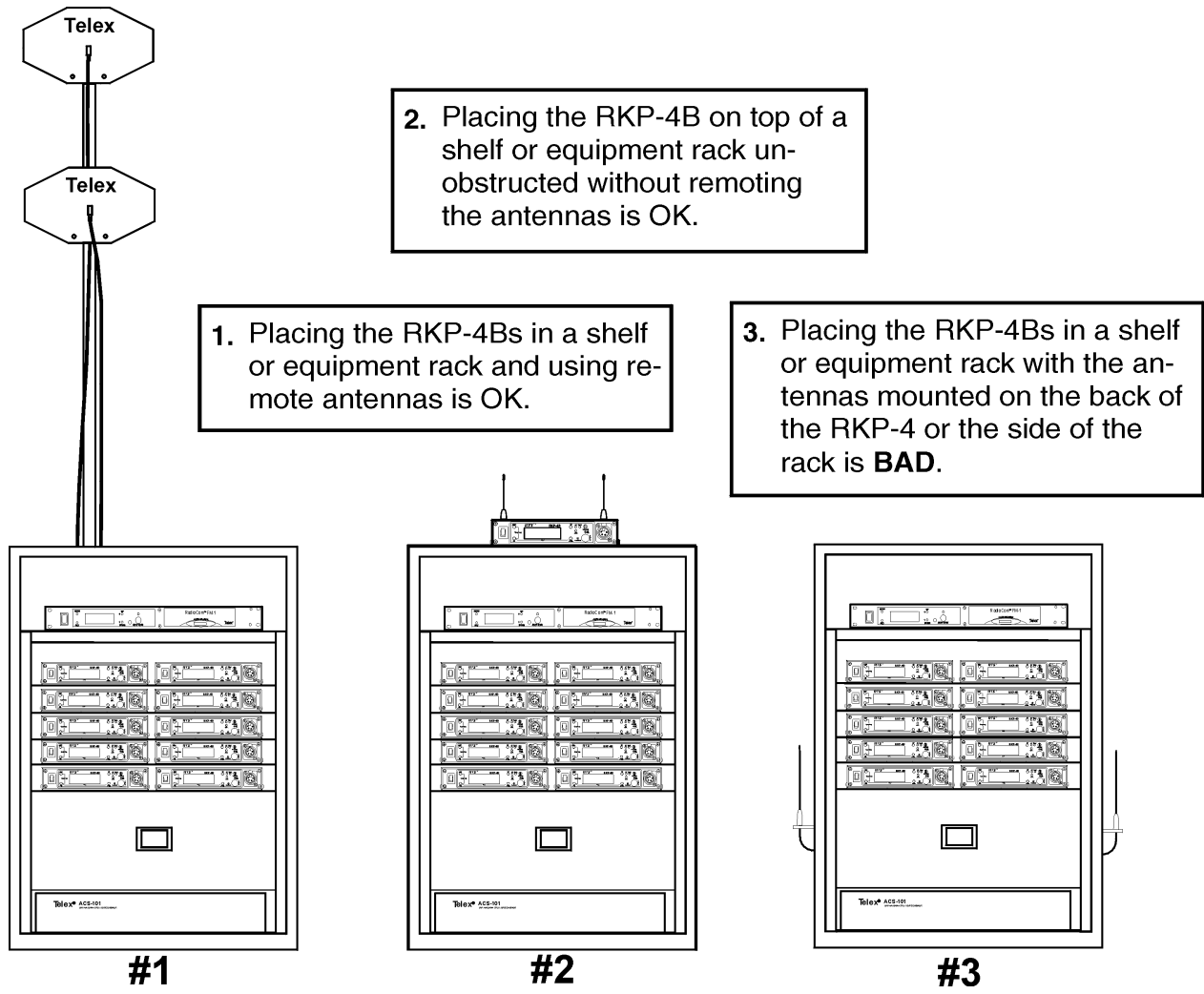

Figure 5-11  
Antenna Placement



# Section 6

## RKP-4B Operation

---

### Basic Operational Description

The RKP-4B is the base station for the RKP-4 beltpack. The wireless keypanel system is a full duplex (simultaneous talk and listen) audio system that is designed to work with Adam™, Adam™ CS and Zeus™ and CRONUS™ Digital Matrix Intercom Systems. The RKP-4's operation is very similar to the MKP-4, BKP-4, TKP-4, and WKP-4, four button wired keypanels.

The beltpack, via the base station, allows communications with a digital matrix and acts as a keypanel on the system. The base has the ability to program the frequencies of the beltpack over-the-air. The sidetone for the base's local headset and the beltpack are adjusted at the base station.

### System Quick Start

The following is a list to quickly get a base station and beltpack operating.

1. Plug the base station into the desired Matrix port.
2. Press <MENU> as powering up the base station.
3. Set the Matrix address and options via the software menu. Reach the parameters to set by pressing <MENU>, then select, "System Settings", now select "Matrix Settings".
4. Press <MENU> as powering-up the beltpack.
5. Press <MENU> on the beltpack until you arrive at the encryption code screen. Press <SET> to begin editing the 4-digit code. Set the code that you wish.
6. When finished with the encryption code, press and hold <MENU> + <UP> for 3 seconds on the beltpack. Then set the 4-digit base serial number on the beltpack's display.
7. At the base station, set the 4-digit encryption code to match the beltpack.
8. The base should now indicate, on the main status screen, a battery voltage and signal strength indicating the base and beltpack are communicating.
9. The beltpack should now indicate dashes on the CWW. This indicates it is communicating with the matrix.
10. Plug a headset into the base and beltpack. Adjust the microphone gain on both so the overmodulation light flashes only on the loudest expected speech level.

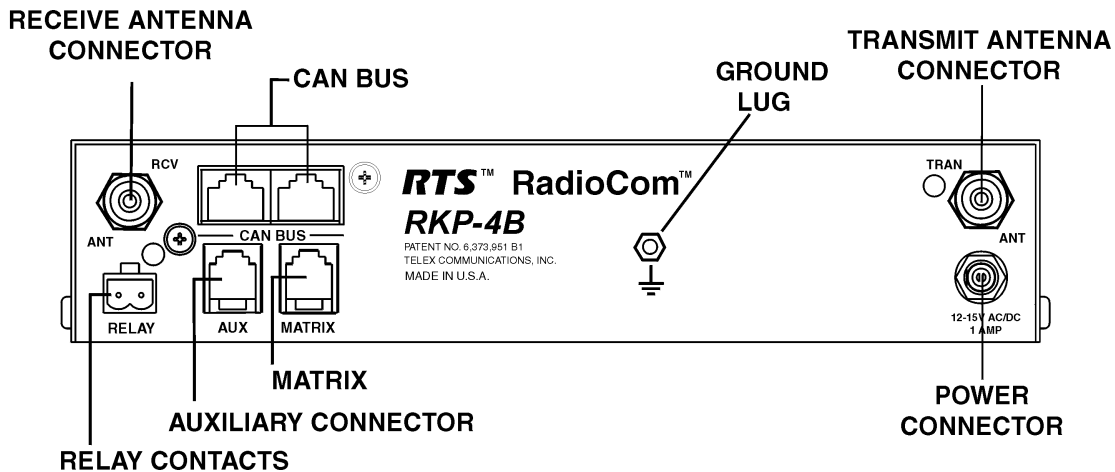

Figure 6-1  
RKP-4B Rear Connectors

## Interfacing to the RKP-4B

### TX/RX Antennas

The TNC jack marked “RCV” is for the receive antenna. The TNC jack marked “TRAN” is for the transmit antenna. The base station will come with two 1/2 wave antennas. Always match the color dot on the base station with the colored band on the antenna.

### Matrix Port

The RKP-4B connects to a matrix via the RJ-12 jack labeled, “MATRIX”. This connector contains input and output balanced audio and balanced data. The pinout for this jack may be seen in Figure 6-2. For a description of how to set up the audio levels at this jack refer to intercom settings in this section.

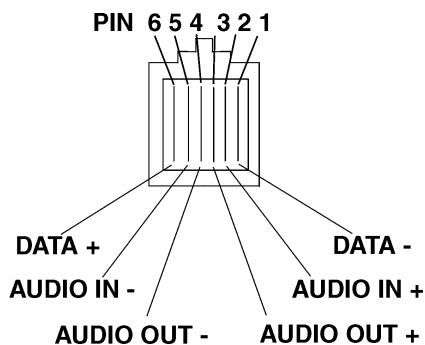

Figure 6-2  
Pinout of the Matrix Jack

### Auxiliary Port

This jack allows a balanced input auxiliary signal to be placed into the base station. It also allows a balanced output signal to be brought out of the base station. The input signal can be software selected to be local or global. A local input signal is only heard at the base station’s local headset and beltpack. A global input signal is placed on the Matrix output audio from the base station. The pinout for this jack is in Figure 6-3.

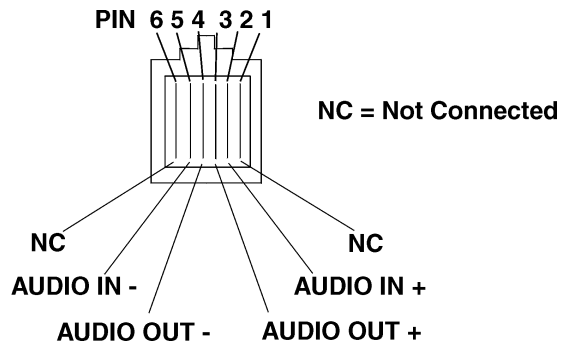

Figure 6-3  
Pinout of the Auxiliary Jack

## CAN Bus

The CAN bus allows the connection of multiple base stations to a Frequency Manager. The Frequency Manager then can be used to set all the base stations to a frequency plan plus set a variety of other options on the base station. The base stations then can program frequencies of their belt-packs via an over-the-air link. Thus a whole system can be set-up with only a few button presses at the frequency manager. Each frequency manager can control up to 10 base stations.

The CAN bus cable starts at the Frequency Manager and then proceeds to the first base station. From the first base station, the CAN bus daily chains through all the base stations, stopping finally at the frequency Manager. Both base station RJ-45 CAN bus connectors are wired in parallel so it does not matter which jack is used for the input or output cable. See Figure 6-4 below for a sample routing of the CAN bus cable. **NOTE:** For clarity the power, interconnect, and TX/RX cables are not shown in the figure.

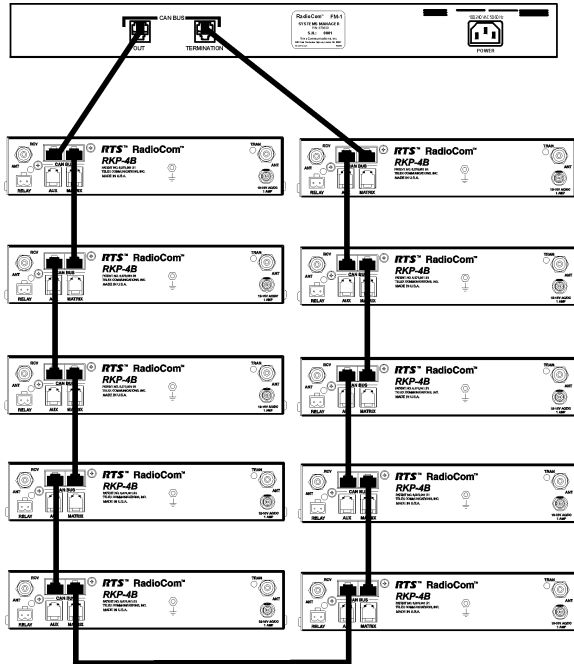

Figure 6-4  
CAN Bus Cables

## Relay

A software selectable relay closure is available at the base station. The relay is normally open, however the base station software options can be set so the relay closes when the belt-pack's relay button is pushed. The relay schematic is shown in Figure 6-5.

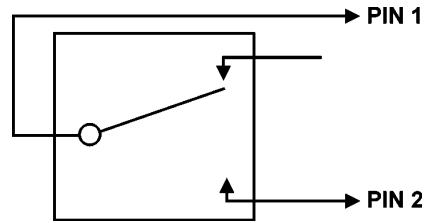

Figure 6-5  
Relay Schematic

Whenever the relay function is activated at the belt-pack, a GPI instruction will be sent to the matrix. This instruction is sent regardless of whether the relay is enabled or disabled via the software menu at the base station.

A "Phoenix" type connector (supplied) plugs into the relay contact port on the base station. This connector provides a screw-type closure for an easy connection to wires.

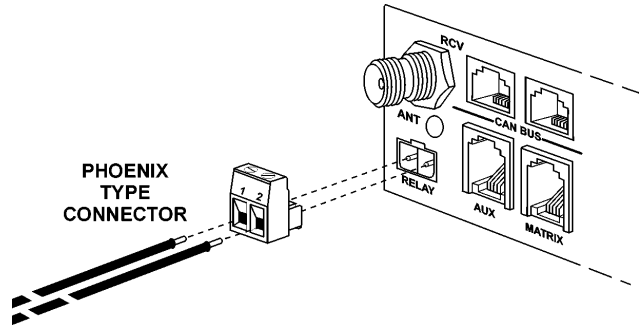

Figure 6-6  
Relay Contact Jack Adapter

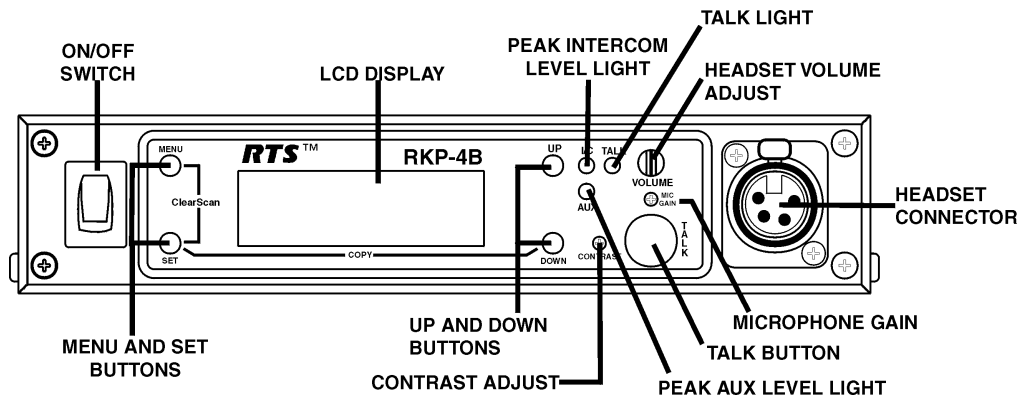

Figure 6-7  
Front Controls and Connector

## Local Headset

The local base station headset allows direct communications to the beltpack. It does not connect to the Matrix.

### Volume Control

Turn control clockwise to increase the headphone volume.

### Talk Button

Press to enable audio path from the headset microphone. The talk light will activate when the talk button is active. This light has two functions. Green indicates activation of the talk button. Red or flashing red on most speech indicates overmodulation (too strong of input audio).

### Overmodulation:

Light flashes on loudest speech = Gain OK  
 Light flashes on all speech = Gain too High  
 Light never flashes on loud speech = Gain too low

### Microphone Gain

The microphone gain of the base station's headset microphone may be adjusted via the pot above the Talk button. A plastic screwdriver was provided with the base station for this purpose. Adjust the gain for the overmodulation setting as shown above.

## Powering the Base Station

The base station requires 12 - 15 Volts AC or DC at 1 Amp for power. The power jack accepts a 5.5 mm x 2.1 mm screw on plug. An inline 12 Volt DC power supply was provided with the base station.

Power the base station via the rocker switch located to the left as facing the base station.



## Start-up

When the RKP-4B is powered-up the 1st screen displayed is the start-up splash screen. It will be displayed for about 2 seconds. This screen contains the software version and channel map versions that are loaded into the base station. The following screen has software version sb10022, and channel map versions B0001 and 30001. This indicates it is a B3 unit.

After 2 seconds the status screen will appear. See the “RKP-4B Menu Structure” section for a flowchart of the main screens.

```
Telex Communications
RadioCom™
sb10022          B0001
                 30001
```

## Status Screen

The status screen is the main information screen of the base station. It displays a number of system items.

- Name of Base Station
- Number of Base Station
- The port the Base Station is connected to on the Matrix
- Group and Channels
- The Bands of System A2, B3, E7, etc.
- The Call Waiting Window (CWW) seen at the beltack
- Battery Life of the Beltack
- The receive signal strength of the beltack transmitter
- The base station transmit power level

```
00TELEX00      No 01
GP  CH █      ----
01  A1        Tx High
B2  m068      RX ████
```

The status screen may be changed to an alternate display by pressing <MENU> for 3 seconds. The alternate display shows the base name and number as double wide and double tall characters. It also indicates the system's band and frequencies in normal characters. Pressing <MENU> for 3 seconds again will revert back to the main status screen.

NOTE: The user may set the default name of the base station to any alpha-numeric name. However, when the beltack is powered-up the name changes to the alpha of the beltack.

```
00TELEX00
01 Tx: B 536.200
   Rx: 3 650.200
```

## Encryption Code

The base station has a four digit, hexadecimal, encryption code that can be set by the user. It must match the code at the beltack in order for communication between the beltack and base station to occur.

```
Security Code
F E 2 8
```

## Changing the Encryption Code

1. From the status screen hit <MENU> once to arrive at the security code / system settings / four wire settings / RF meter menu screen.
2. Select the security code menu with the <UP>/<DOWN> arrow buttons and press <SET> to go to the security code screen.
3. The first code position will be flashing. Set the digit by using the <UP>/<DOWN> arrow buttons and press <SET> to go to the security code screen.
4. After the last code position is set press <MENU> to go back to the status screen or press <SET> to begin editing again.

## System Settings

The systems settings allows a number of base station characteristics to be set. This includes base name, base number, aux type, base TX power, Matrix configuration options, sidetone and frequencies.

### Name and Number

The name of the base station may be set to any 10 digit alphanumeric character. For example, the name of the user may be entered. This provides an easy identifier to the user as to who's base station it is.

The number of the base station can also be set from 1 to 10. This is NOT the Matrix address. The Matrix address is set under "Matrix Settings". In a system of base stations managed by a frequency manager the base number must be set to a unique number because this is how the frequency manager identifies the base station.

```
NAME:      ABCDEFGHI
00TELEX000 JKLMNOPQR
NUMBER: 01  STUWXYZ
          0123456789
```

### Changing the Base Name and Number

1. From the status screen hit <MENU> once to arrive at the security code / system settings / four wire settings / RF meter menu screen
2. Select the system settings menu with the <UP>/<DOWN> arrow buttons and press <SET> to go to base setting sub-menu.
3. Select the base name and number menu with the <UP>/<DOWN> arrow buttons and press <SET> to go to the base name and number set screen.
4. The first name position will be flashing. Set the alphanumeric character by using the <UP>/<DOWN> arrow buttons then pressing <SET> to go to the next position. Up to 10 characters may be set.
5. After the alphanumeric characters are set the screen proceeds to the number selection. Select the number menu with the <UP>/<DOWN> arrow buttons and press <SET> to set it.
6. After the number is set press <MENU> to go back to the status screen or press <SET> again to begin the process over again.

## Base Main Settings

This important screen enables the user to set the wired intercom type connected to the system, the auxiliary input type, the transmitter power, BP Off Mode, and the base station and beltpack side tone levels.

```
AUX LINE:  LOCAL
BASE Tx:   HI
BTR SIDETONE  --■ ■ ■
TR SIDETONE  --■ ■ ■
```

### Auxiliary Line

The auxiliary line may be set to local or global.

**Local** = Any audio placed into the auxiliary input port is routed only to the base station's local headset and beltpack.

**Global** = Any audio placed into the auxiliary input port is routed not only to the base station's local headset and beltpack, but also to the wired system connected to the matrix port.

### Base TX Power

The base station transmit power can be set to two positions.

**NORM** = The transmit power is about 10 dB below maximum power. This is 5 mW typically.

**HI** = The transmit power is at full power. This is 50 mW typically.

### Sidetone Levels

The sidetone is the amount of a user's own voice that is feed back to their headphones. Both the beltpack and base station sidetone may be adjusted in the base main settings.

## Changing the Auxiliary types, TX power and Sidetone

1. From the status screen hit <MENU> once to arrive at the security code / system settings / four wire settings / RF meter menu screen.
2. Select the system settings menu with the <UP>/<DOWN> arrow buttons and press <SET> to go to the base station settings sub-menu.
3. Select the base main settings menu with the <UP>/<DOWN> arrow buttons and press <SET> to go to the base station main settings set screen.
4. The aux line type will be flashing. Set local or global by using the <UP>/<DOWN> arrow buttons then press <SET> to go to the base station Tx options.
5. The Tx option will be flashing. Set Norm or High by using the <UP>/<DOWN> arrow buttons then press <SET> to go to the sidetone option.
6. The RKP-4B sidetone will be flashing. Set the base side level by using the <UP>/<DOWN> arrow buttons then press <SET> to go on to the RKP-4 sidetone level.
7. After the RKP-4 sidetone is set press <MENU> to go back to the status screen or press <SET> again to begin the editing of the base main setting again.

## Frequency Settings

The group and channels of factory defined groups may be changed in this screen. However, factory defined frequencies cannot be changed. User defined groups and channels may be defined in this screen too. The user defined frequencies can be changed by the user.

GP 01	Ch A1
Tx	Rx
536.200	650.200
TU 25	TU 44

Whenever the group, channels or frequencies are changed at the base, it will display the following screen.

Setting BeltPack Frequencies Please Wait . . .
--

This will occur regardless if a beltpack communicating to the base station or not. It is a broadcast type of message. If a beltpack is in communication with the base station, then a software menu function in the beltpack determines if that beltpack will follow the base to the new frequencies or stay where it is. The option is called, "Auto Programming". The beltpack auto programming must be set to ON for automatic frequency programming of the beltpack to occur. More detail on these two options may be found in the "RKP-4 Operation" section of the manual.

## Changing Groups / Channels / Frequencies

1. From the status screen hit <MENU> once to arrive at the security code / system settings / four wire settings / RF meter menu screen.
2. Select the system settings menu with the <UP>/<DOWN> arrow buttons and press <SET> to go to the base station settings sub-menu.
3. Select the frequency settings menu with the <UP>/<DOWN> arrow buttons and press <SET> to go to the Groups/Channels/Frequencies set screen.
4. The group will be flashing. Set desired groups by using the <UP>/<DOWN> arrow buttons then press <SET> to go to the transmit channel.
5. The transmit channel will be flashing. Set the channel by using the <UP>/<DOWN> arrow buttons then press <SET> to go to the receive channel.
6. The receive channel will be flashing. Set the channel by using the <UP>/<DOWN> arrow buttons then pressing <SET> to end editing in factory defined groups.
7. In factory defined groups, after the RX channel is set press <MENU> once to go back to the status screen. Press <SET> again to begin the editing of the screen again. In user defined groups the editing continues with the Tx frequency then Rx frequency. Once these are set, press <MENU> once to go back to the status screen or press <SET> again to begin the editing of the screen again.

## Matrix Settings

There are four options to set in this screen. Any changes in these settings requires the power of the belt-pack and the base station to be reset.

The settings are the following:

- **Display Call**
  - Enable - (Default) All incoming calls appear in the call waiting display.
  - Disable - LED flashes until caller releases key.
- **Key Flash**
  - Enable - (Default) 15 second flash after incoming call is received.
  - Disable - LED flashes until caller releases key.
- **Latch Keys**
  - Enable - Latching is turned on.
  - Disable - (Default) Latching turned off.
- **Matrix Address**

Intercom ports are arranged in groups of eight. Within each group, a keypanel is uniquely identified by its address switch setting. Set the number of the RKP-4 system here. Valid selections are 1 - 8.

## Four Wire Settings

This screen provides the ability to set the following:

- 4W input and output audio levels
- Auxiliary ON/OFF
- Auxiliary input and output audio levels
- Relay ON/OFF

The 4W input and output levels referred to in this section are those at the matrix RJ-12 connector. The Relay button on the belt-pack also has the added selectable options of relay latching or non-latching.

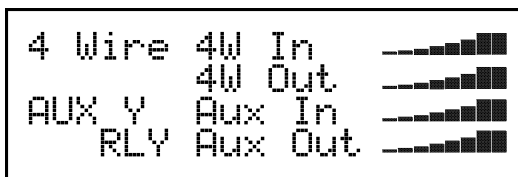

## Setting the 4-Wire, Aux and Relay Options

1. From the status screen hit <MENU> one to arrive at the security code / system settings / four wire settings / RF meter menu screen.
2. Select the four wire settings menu with the <UP> / <DOWN> arrow keys and press <SET> to go to the setting's screen.
3. The 4W input level will be flashing. Select the desired level by using the <UP> / <DOWN> arrow buttons then pressing <SET>. The 4W output level will now be flashing.
4. Select the desired output level by using the <UP> / <DOWN> arrow buttons then pressing <SET>. The aux Yes or No option will now be flashing.
5. Use the <UP> / <DOWN> arrow keys to select aux input audio Yes or No. Press <SET> to accept the choice.
6. If aux input was set to "Y" then the user will be asked to set the auxiliary input and output levels. Use the <UP> / <DOWN> arrow keys to adjust the input and output levels, then press <SET> to accept the levels. The Relay option will now be flashing.
7. To enable the relay function the "RLY" letters should be setting to normal by using the <UP> / <DOWN> arrow buttons then press <SET>. To disable the relay set the "RLY" to inverted letters then press <SET>.
8. Press <MENU> to go back to the status screen, press <SET> to continue editing options at the beginning of the screen.

## RF Meter

This screen displays a larger version of the 5 bars of received signal strength displayed on the status screen. It also displays the receive frequency.

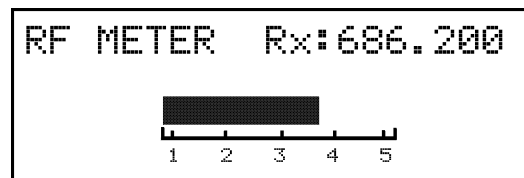

## Changing to the RF meter screen

1. From the status screen hit <MENU> once to arrive at the security code / system settings / four wire settings / RF meter menu screen.
2. Select the RF meter menu with the <UP> / <DOWN> arrow keys and press <SET> to go to the RF meter.

## ClearScan™

Press and hold <MENU> + <SET> for 3 seconds to enter the ClearScan™ menu. There will be three options from which to choose from by using the <UP>/<DOWN> arrow buttons and then press <SET>. Those options and the results are explained below.

### ClearScan™ Groups

This option scans all the groups in the base station. The group with the highest number of clear receive channels is listed at the top of the list (<UP> arrow all the way to the top). The next group down has the second highest number of clear receive channels and so forth. Channels that clearly have RF interference on them are inverted.

```
GROUP 04      Prev ↑
  1 2 3 4 5 x
OK?=[SET]    Nest ↓
```

A possible result of ClearScan™ Groups is shown below:

✕ = No frequency in that receive channel position. It would be dashed lines if examined in the group/channels screen.

4 = Interference found on the receive channel during the groups scan.

After a group is decided upon, press <SET> to select that group. A ClearScan™ Channel is now initiated. See ClearScan™ Channels description.

### ClearScan™ Channels

This option scans all the receive channels within the base station's currently set group. This scan is also initiated after a ClearScan™ Group in order to find the clear receive channels within that group. The receive channel with the least amount of RF noise on it is listed at the far left (<UP> arrow all the way to the left). The next channel to the right has the next least amount of RF noise on it and so forth. Channels that clearly have RF interference on them are inverted.

A possible result of a ClearScan™ Channel is shown below.

```
GROUP 01      Prev ↑
  5 1 3 4 2 6
OK?=[SET]    Nest ↓
```

6 = Interference found in the receive channel during the scan or no receive frequency in that receive channel position

After a channel is decided upon, press <SET> to select that channel.

### ClearScan™ Band

This option continuously scans the whole receive band until user intervention. The scan starts at the beginning of the band, then checks and records every 200kHz for the RF received signal strength level. Press <SET> to store the results in user group 63u. Press <MENU> to bail out of the band scan without saving any results. The results of the six clearest RF frequency areas are listed in the receive side of user group 63u. Channel 1 is the best (clearest) frequency found, channel 2 is the next best and so forth to channel 6.

```
GP 63u      CH A1
Tx          Rx
-----
TV ---     TV 52
```

## Special Button Functions

### Factory Defaults

Press and hold <MENU> + <SET> + <DOWN> for 3 seconds. A screen displaying, "Factory Defaults" will then appear.

This function sets the base station to Group 1, channels A and 1 a ERASES any user defined groups in memory. It will also set the unit to factory defined parameters.

### 1st Use Defaults

Press and hold <MENU> while turning on the base station. A screen displaying, "Factory Defaults" will then appear.

This function sets the base station to Group 1, channels A and 1 and RETAINS any user defined groups in memory. It will also set the unit to factory defined parameters.

## Alternate Screen

Press and hold <MENU> for 3 seconds to toggle between the alternate screen and the status screen. The alternate screen is shown below.

```
00TELEX00
01 Tx: B 536.200
   Rx: 3 650.200
```

The alternate screen displays the base name and number in double wide double tall characters. Up to ten character in the name can be displayed. It also shows the bands of the unit and the currently set frequencies.

## Lockout

Press and hold the <UP> + <DOWN> buttons for 3 seconds to lock or unlock the base station. A padlock will appear on the status and alternate screens if the base is locked.

This function locks out a user from changing any options at the base station.

## Copy

Press and hold the <SET> + <DOWN> buttons for 3 seconds and the following screen will appear:

```
Copy Group 01
to Group 51u
```

This allows the user to select a user group to copy the current group too. Not the user could edit that group slightly if desired.

## Display Start-up Screen

Press and hold <DOWN> + <TALK> for 3 seconds.

```
Telex Communications
RadioCom™
sb10022      00001
              30001
```

This function allows the user to check the software and channel map version of the base station without rebooting the base.

# Section 7

## RKP-4 Operation

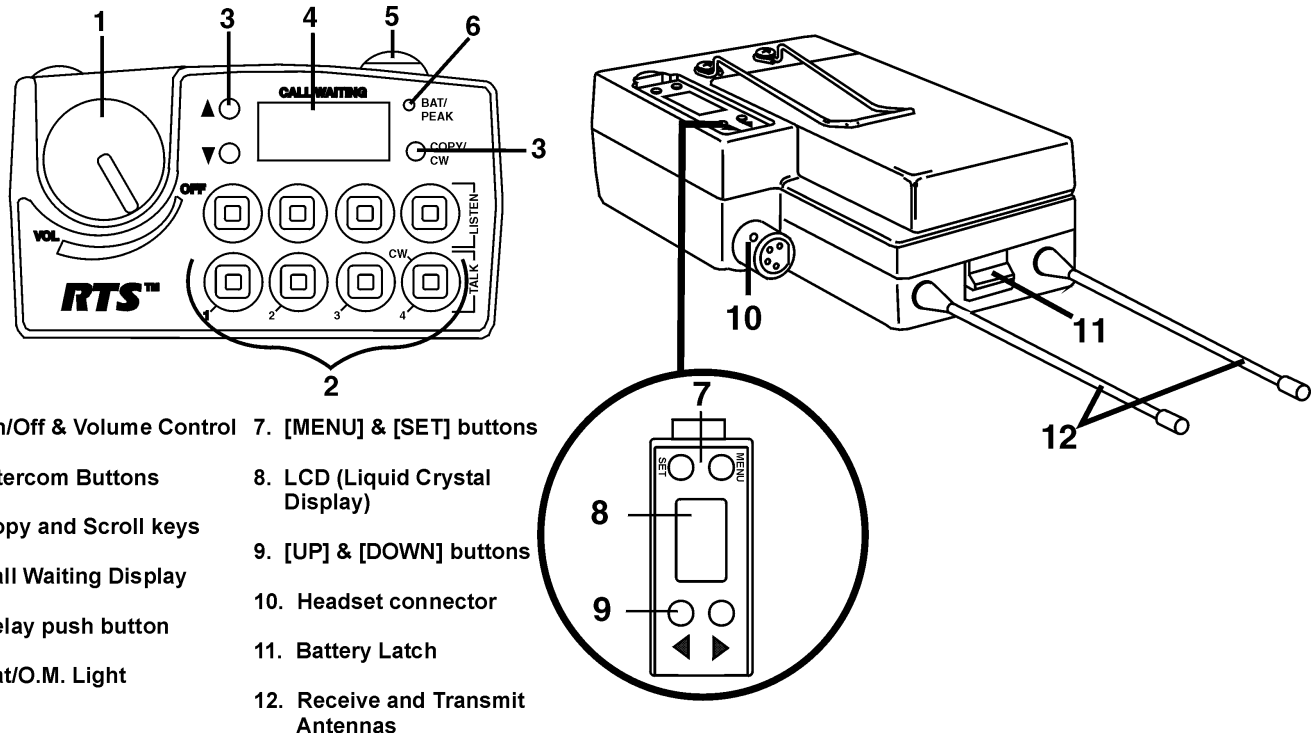

1. On/Off & Volume Control
2. Intercom Buttons
3. Copy and Scroll keys
4. Call Waiting Display
5. Relay push button
6. Bat/O.M. Light
7. [MENU] & [SET] buttons
8. LCD (Liquid Crystal Display)
9. [UP] & [DOWN] buttons
10. Headset connector
11. Battery Latch
12. Receive and Transmit Antennas

### RKP-4 Operation

#### Basic Operational Description

The RKP-4 is the belt-pack for the RKP-4 keypanel system. The wireless system is a full duplex (simultaneous talk and listen) audio system that is designed to work with Adam™, Adam™ CS and Zeus™ and CRONUS™ Digital Matrix Intercom System. The RKP-4's operation is very similar to the MKP-4, TKP-4, and WKP-4, four button wired keypanels.

The belt-pack, via the base station, allows communications with a Digital Matrix and acts as a keypanel on the system. The base has the ability to program the frequencies of the belt-pack over-the-air. The sidetone for the base's local headset and the belt-pack are adjusted at the base station.

#### System Quick Start

The following is a list to quickly get a base station and belt-pack operating.

1. Plug the base station into the desired Matrix port.
2. Press <MENU> as powering up the base station.
3. Set the Matrix address and options via the software menu. Reach the parameters to set by pressing <MENU>, then select, "System Settings", now select "Matrix Settings".

4. Press <MENU> as powering-up the belt-pack.
5. Press <MENU> on the belt-pack until you arrive at the encryption code screen. Press <SET> to begin editing the 4-digit code. Set the code that you wish.
6. When finished with the encryption code, press and hold <MENU> + <UP> for 3 seconds on the belt-pack. Then set the 4-digit base serial number on the belt-pack's display.
7. At the base station, set the 4-digit encryption code to match the belt-pack.
8. The base should now indicate, on the main status screen, a battery voltage and signal strength indicating the base and belt-pack are communicating.
9. The belt-pack should now indicate dashes on the CWW. This indicates it is communicating with the matrix.
10. Plug a headset into the base and belt-pack. Adjust the microphone gain on both so the overmodulation light flashes only on the loudest expected speech level.

## Battery Installation

Ensure that the On/Off volume control knob is turn off. Press down and hold down the battery release latch, slide the battery pack about 1/8 inch back, toward the latch, until it stops. Then lift battery pack out. Replace batteries as follows:

1. Open the battery pack by inserting finger nail and lifting.

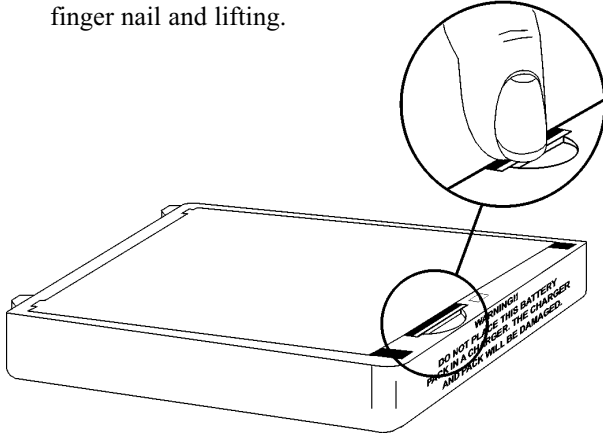

2. Pull battery strap to remove low or dead batteries.

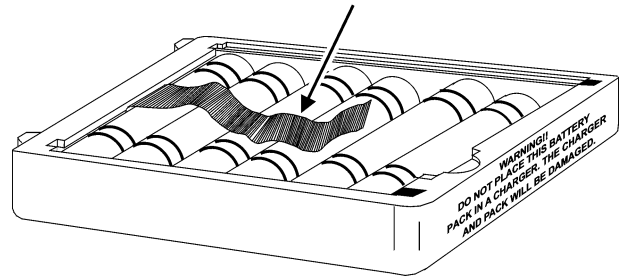

3. Load new batteries following the polarity as shown in battery case.

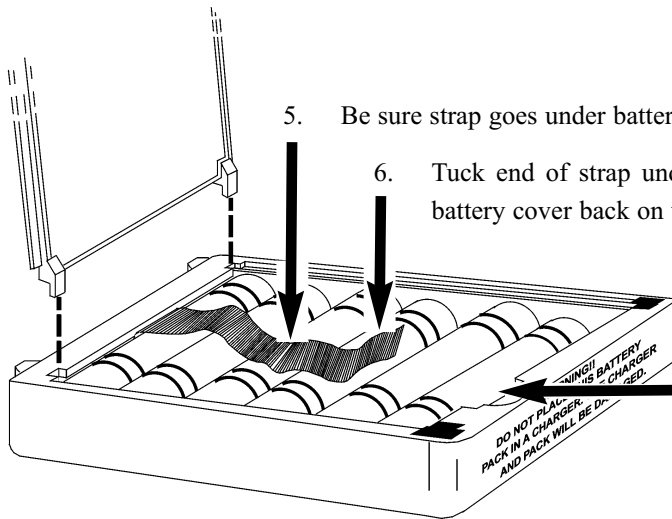

5. Be sure strap goes under batteries.

6. Tuck end of strap under door when placing the battery cover back on the case.

4. Start loading at the end of the case where the strap is attached to the case.

Figure 7-2  
Battery Installation

**WARNING:** Do not place an alkaline battery pack in any battery charger. Severe charger and battery pack damage may result.



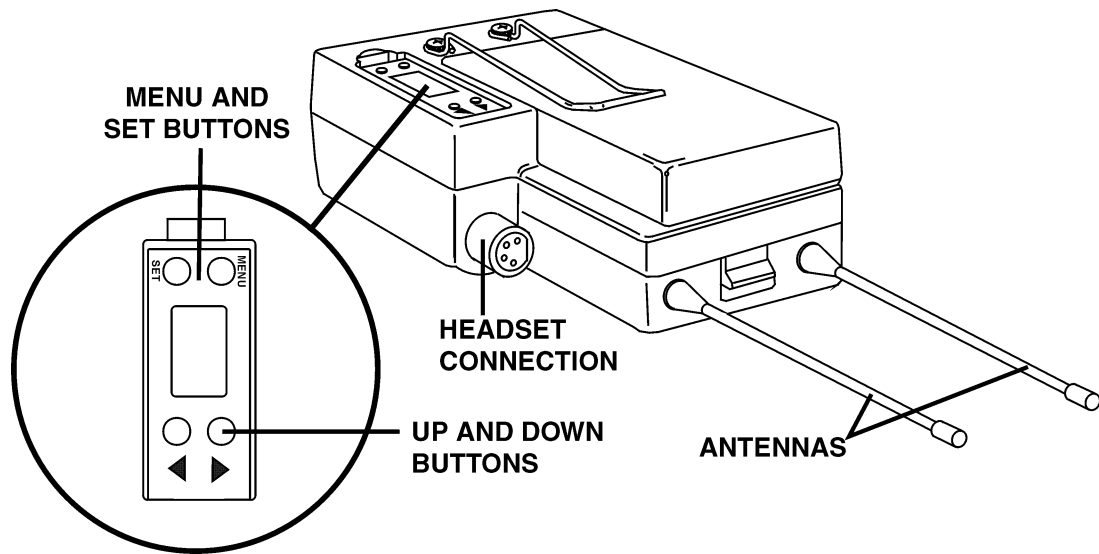

Figure 7-3  
RKP-4 Controls

### Headset Connection

The headset connector is a XLR type connector. Four or five pin headset connectors may be installed in the unit. See the “RKP-4 Controls and Connections” section for information on the pinouts. A dynamic or electret headset microphone is automatically detected by the beltpack and a bias voltage supplied if needed.

### Sidetone

Sidetone is the amount of the users voice that is feedback to their headphone. The sidetone level in the beltpack is set at the base station. Please see “RKP-4B Operation” section for how to set this level.

### Antenna Connection

The beltpack comes with two detachable, screw type, 1/4 wave antennas. Attach the two antennas by screwing the antennas into the receptacles at the bottom of the beltpack. The color dot on the screw end of the antenna must match the color dot on the antenna receptacle.

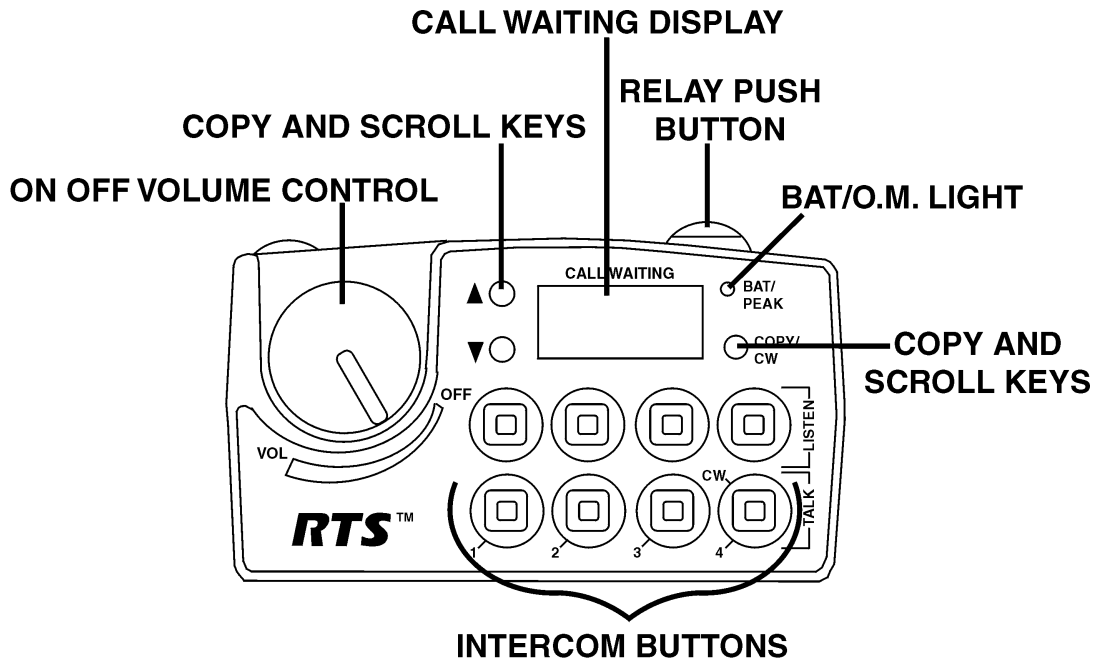

Figure 7-4  
RKP-4 Controls

### RKP-4 Top Panel

**On/Off & Volume Control:** Turns the belt-pack power on and controls headset volume.

**Intercom Buttons:** Assignable for several types of operation, including talk only, listen only, talk with auto-listen, and all-call (where activating the key also activates all keys to the left of that key). Keys feature momentary or latching operation. For momentary operation, the operator presses and holds a key while communicating, then releases it when finished. For latching operation, the operator taps a key to turn it on, then taps it again to turn it off. Latching can be disabled via software options in the base station or from AZedit. Two bi-color (red and green) LED indicators for each key provide indications for talk on/off, listen on/off, incoming call, busy (for keys assigned to talk to IFB's), and in-use (for keys assigned to talk to either IFB's or ISO's).

**Copy and Scroll keys:** Used for key and setup page assignment. Can also be used to talk to any location in the intercom system when no intercom key is assigned. (Note: There are 4 setup pages. Each contains a complete set of key assignments.)

**Call Waiting Display:** 4-character, alphanumeric display for incoming caller names.

**Relay push button:** A momentary or latching (set via belt-pack software) push button for activating the relay contact closure on the rear of the base station.

### BAT/O.M. Light

<b>Battery</b>	Light flashes on power up	= Battery OK
	Light on continuously	= Battery Low
	Light does not flash or come on	= Battery Dead
<b>Overmodulation</b>	Light flashes on loudest speech	= Gain OK
	Light flashes on all speech	= Gain too high
	Light never flashes on loudest speech	= Gain too Low

## Group and Channels

The first screen the beltpack displays on the rear LCD, after power-up, is the group / channels screen. This screen shows the currently selected group followed by the receive and transmit channels where the unit is set.

### Editing Group / Channels

1. Push <SET> to edit the group. The group number will begin flashing.
2. Select the desired group with the, <UP>/<DOWN> arrow buttons.
3. Push <SET> to accept the group. The receive channel letter will now begin flashing.
4. Select the desired channel with arrow buttons.
5. Push <SET> to accept the receive channel. The transmit channel number will now begin flashing.
6. Select the desired channel with the arrow buttons.
7. Push <SET> once more to accept the transmit channel.
8. The new group containing the selected channels is now set.

**NOTE:** Pressing <MENU> during the group/channels editing will bail out of the editing without any changes.

Factory group's frequencies are not changeable.

User group's (Group 51u to 64u) frequencies are changeable.

### Transmit Frequency

This screen displays the frequency in MHz of the beltpack transmitter. The frequency is not changeable in factory defined groups. The frequency is changeable in user groups.

#### Editing the Tx Frequency (User Groups Only)

1. Set the unit to the desired user defined group and channels. See Groups and Channels Instructions. The menu structure at the right (Figure 7-5) indicates how to get to the transmit frequency screen.
2. Push <SET> to edit the TX frequency. The frequency will begin flashing.
3. Select the desired frequency with the <UP>/<DOWN> arrow buttons. The frequency can be changed in 25 kHz steps.
4. Push <SET> to place the unit on the new transmit frequency.

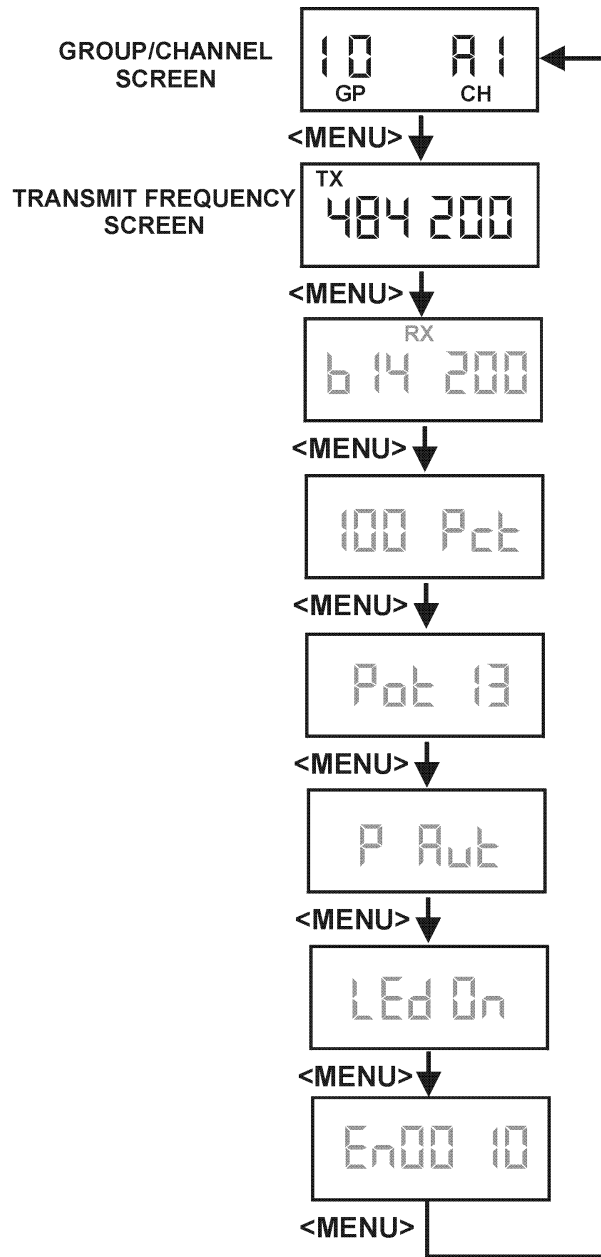

Figure 7-5  
Group/Channel and Transmit Frequency Screen

## Receive Frequency

This screen displays the frequency in MHz of the beltpack receiver. The frequency is not changeable in factory defined groups. The frequency is changeable in user groups.

### Editing the RX Frequency (User Groups Only)

1. Set the unit to the desired user defined group and channels. See groups and Channels Instructions. The menu structure at the right (Figure 7-6) indicates how to get to the receiver frequency screen.
2. Push <SET> to edit the RX frequency. The frequency will begin flashing.
3. Select the desired frequency with the <UP>/<DOWN>
4. Push <SET> to place the unit on the new receive frequency.

## Battery Display

The battery display screen indicates the current percentage of battery life based upon alkaline batteries being used in the unit. NiMH battery packs will lose voltage much faster than alkaline batteries toward the end of life.

### Battery Percentages

100 Pct = Fresh Battery

75 Pct = 75% life Left

50 Pct = 50% Life Left

25 Pct = 25% Life Left

10 Pct = 10% Life Left. Low battery Light Active.

0 Pct = Battery Dead. Unit will lose communication at any time.

### Setting the Low Battery Alert Tone

The beltpack has an audio alert tone that is sent to the headphone if the battery life reaches 10%. The tone is at 1 kHz and is heard for 0.5 seconds every 30 seconds. The tone is only heard at the beltpack. The alert tone function may be turned on or off at the beltpack.

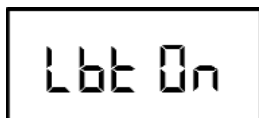

### Low Battery Alert Tone On/Off

1. Press <SET> at the battery percentage screen. The screen above will appear.
2. The low battery tone option will also begin flashing.
3. Use the <UP>/<DOWN> arrow buttons to turn the option on or off.
4. Push <SET> to accept the change. The display will now return to the battery life screen.

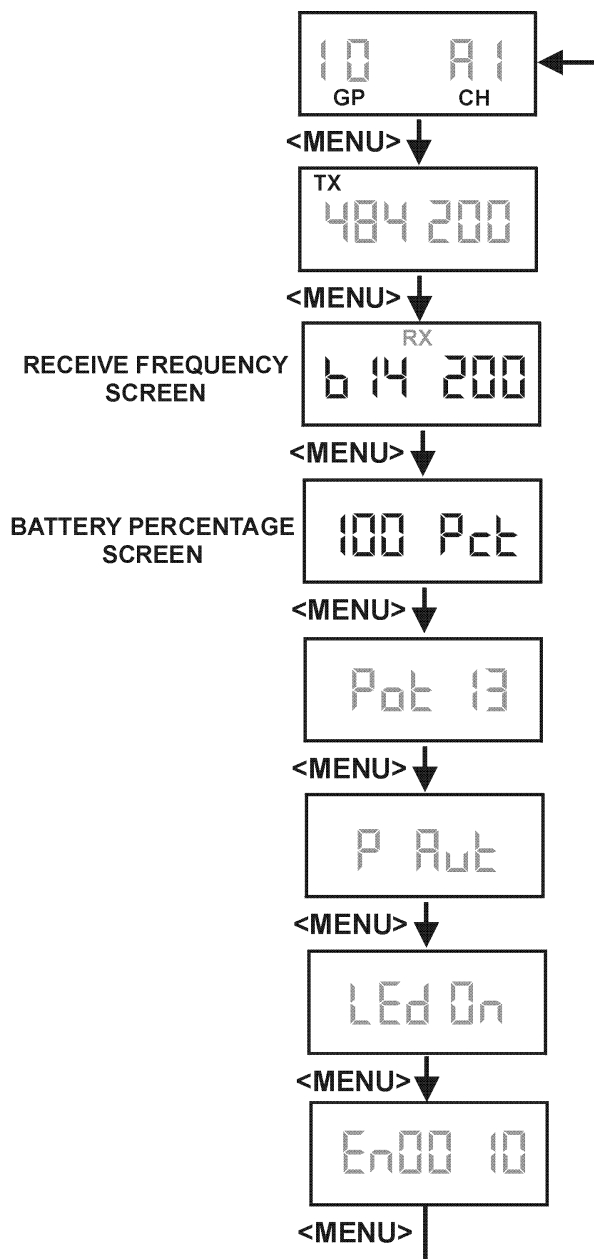

Figure 7-6  
Receive Frequency/Battery Percentage Screen

## Microphone Gain

This screen displays the setting of the microphone gain of the beltpack. There are 16 possible settings. The number 0 indicates no microphone gain, the number 15 is maximum gain. Each step is about 3 dB of audio.

### Adjusting the Microphone Gain

1. Push <SET> at the microphone gain screen. The number will begin flashing.
2. Select the desired gain with the <UP>/<DOWN> arrow buttons.
3. Push <SET> to place the unit at the indicated microphone gain.

## Transmit Power

The transmit power screen displays the current setting of the beltpack transmitter's output power level.

### Transmit Power Settings

<b>Auto (Default)</b>	The beltpack's transmitter adjusts its output level according to information sent to the beltpack from the base station. NOTE: A decimal point in the display indicates the transmitter is at high power, no dot means the unit is at low transmit power.
<b>High</b>	The beltpack is transmitting at full power, nominal 50 mW, constant.
<b>Low</b>	The transmitter is at low power, nominal 5 mW, constant.

When the unit is set to auto the the beltpack will set its power setting according to information being sent from the base station. The base station information will tell the beltpack the appropriate power setting to use based upon received signal strength level at the base station from the beltpack. By reducing the transmit power when possible, the battery life of the beltpack can be slightly extended. Also intermodulation products can be reduced.

### Changing the Transmit Power Setting

1. Push <SET> at the transmit power screen. The power setting will begin flashing.
2. Select the power setting with the <UP>/<DOWN> arrow buttons.
3. Push <SET> to place the unit at the indicated setting.

## Dark Operation

This option allows the user to turn off all LEDs and backlight LCD CWW for dark operation. The intent of this operation mode is for theater and other similar environments where the LED's light may distract from the performance when being used in the background, such as lower catwalks above the stage. If the CCW LCD is backlit when dark operation is activated it will remain lit until it times out or is turned off by a <COPY> then <LISTEN4>. It will then no longer activate.

### LED On/Off operation

1. Push <SET> at the LED On/Off screen. The setting will begin flashing.
2. Select the desired setting with the <UP>/<DOWN> arrow buttons.
3. Press <SET> to place the unit on the indicated setting.

## Encryption Code

The encryption code screen allows the setting of four hexadecimal digits. Any combination of letters and/or numbers may be selected. The beltpack's code must match the base station's code for audio recovery. This code along with the serial number encryption code discussed on the next page, means there is over 4 billion possible code combinations.

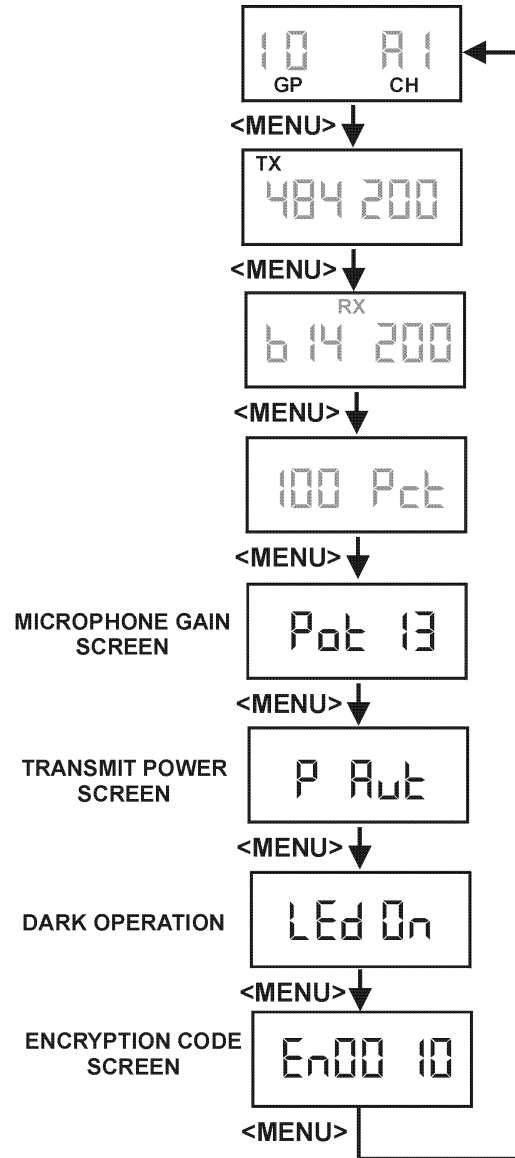

Figure 7-7  
Microphone Gain Screen and Transmit Power Screen

### Changing the Encryption Code

1. Push <SET> at the encryption code screen. The first code location will begin flashing.
2. Select the desired number / letter with the <UP>/<DOWN> arrow buttons.
3. Push <SET> to set the code. Now the next code location will begin flashing.
4. Set the next three code locations in the same manner.

## Serial Number Code

The base serial number is required to be input to the beltack to allow communication with that base station. The number like the encryption code, is composed of four hexadecimal digits. This extra security along with the encryption code means there is over 4 billion possible code combinations.

### Changing the Serial Number Code

1. Press and hold <MENU> + <UP> buttons at the encryption code screen for about 3 seconds. The serial number set screen will appear.
2. Push <SET> to start the first number flashing. Select the desired number with the <UP> <DOWN> / arrow buttons.

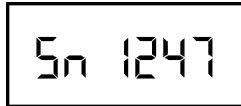

3. Push <SET> to set the code. Now the next code location will begin flashing.
4. Set the next three code locations in the same manner.

## Auto Programming

This function allows the base station to change the beltack's frequencies "over-the-air". Thus whenever the base station's groups / channels are changed the beltack will automatically follow. If the beltack's frequencies are changed "over-the-air", the beltack will place those frequencies in group 64u, and go to group 64u.

Auto frequency programming, via the base station changing frequencies, only will occur at the beltack if the following is set: Beltack already in communication with the base station, beltack auto programming set to on and beltack power transmit power set to auto.

### Enabling / Disabling Auto Programming

1. In any of the beltack main screens press and hold <UP> the button for 3 seconds. The following screen will appear.
2. The auto programming option will also begin flashing.



3. Use the <UP>/<DOWN> arrow buttons to turn the option on or off.
4. Push <SET> to accept the change. The display will now return to the main screen.

## Software / Channel Map Version

The software and channel maps of the beltack may be displayed from any of the main beltack screens.

### Viewing the Software and Channel Map Version

1. In any of the beltack main screens press and hold the <DOWN> button for 3 seconds. The following screen containing the software version will appear.
2. As long as the <DOWN> button is pressed the software version in the beltack will be displayed.



3. When the button is released the following two channel map screens will be displayed for a second each.
4. The first screen indicates the receive channel map in the beltack. The second screen indicates the transmit channel map. The above screens indicate that it is a A4 band beltack.
5. The screen will now revert back to the main screen.



## ClearScan™

ClearScan™ allows the selection of RF clear channels in an area. The beltack **ClearScan™** has three modes:

1. **Scan Groups**- The beltack's receiver scans all the factory defined groups and any user defined groups that have been set. The result is a list of the top 20 groups, ranked in order of the most clear receive channels in that group. The <UP> arrow all the way to the top is the group with the most clear channels.
2. **Scan within a Group** - The beltack's receiver scans all the receive channels within a group. The result is a list of the channels in that group ranked in order of best to worst channels. The <UP> arrow all the way to the top is the channel that is the best.
3. **Scan Band** - The beltack's receiver scans the entire band of frequencies continuously. It starts at the beginning of the receive band and checks the frequency every 100 kHz until the end of the receive band, then starts over. The user must push <SET> to stop the scanning. The 100 kHz step size is as close as is needed because the narrowest receive filters are 230 KHz wide. This is why every 25 KHz is not scanned.

## Entering ClearScan™

1. Press and hold <MENU> + <SET> for 3 seconds. The following screen will appear:

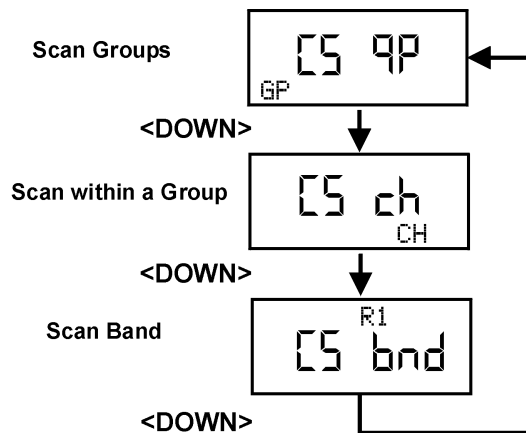

Figure 7-8  
ClearScan™ Menus

2. Use the <DOWN> arrow button to select the type of ClearScan™ desired.
3. Push <SET> to start the ClearScan™
4. **Scan Groups**
  - a. After the scan is done the group icon will be flashing. The left side of the screen will display the group.
  - b. Use the <UP> / <DOWN> arrow buttons to select a group, then push <SET> to set the group and start the channel scan within that group.
  - c. After the scan within a group use the <UP> / <DOWN> to select a channel.
  - d. Hit <SET> to set the channel. The unit will now be set to the group selected earlier and the receive channel just selected.

**NOTE:** The transmit channel will be the one in that group that the unit was already set to. The ClearScan of the base station would select the best beltpack transmit channels to use.

### 5. Scan within a Group

- a. After the scan is done the channel icon will be flashing. The right side of the screen will display the best channel in the group. Use the <UP>/ <DOWN> arrow buttons to select a channel then push <SET> to set the channel.

### 6. Scan Band

- a. Push <SET> to stop the scan band searching. The unit will sort the result and display the top 20 clear frequencies.
- b. Use the <UP>/<DOWN> arrows to select a frequency then push <SET>.
- c. The receive frequency is placed in user group 63u.

**NOTE:** The transmit frequency will not be in group 63u. The frequency to enter for transmit would be the result a base station scan band.

## Special Button Features

### Factory Defaults

1. Press and hold the <MENU> + <SET> + <UP> + <DOWN> for three seconds.

This function sets the beltpack to Group 1, channels A and 1 and ERASES any user defined groups in memory. It will set unit to factory defined menu settings. It will also set the “Talk” and “relay” button to their default modes.

### 1st Use Defaults

This function sets the beltpack to Group 1, channels A and 1 and leaves any user defined groups in memory. It will set unit to factory defined menu settings. It will also set the “Talk” and “relay” button to their default modes.

### Activating 1st Use

1. Press and hold the <MENU> button as powering-up the beltpack.

### Lock Out

This function allows the user to lock the top panel and menu options. The call waiting window button and intercom button will still work but the relay button mode cannot be changed. Likewise the values in the screens of the beltpack’s rear LCD can be viewed but not changed.

### Enabling / disabling Lock Out

1. Press and hold The <UP> and <DOWN> buttons for three seconds. The work “SECURE” will appear on the screen when lockout is active.
2. Press and hold the <UP> and <DOWN> button for three seconds again to disable lockout. The work “ACCESS” will appear.





# Section 8

## Operation with a Matrix

---

### Startup and Operational Check

When power is applied, all LEDs will first flash green, then red (unless the beltback is in dark operation. See “RKP-4 Operation”). This confirms that all LEDs are working correctly. Also, the call waiting window will display asterisks (\*\*\*\*) then dashes (----).

**NOTE:** If the RKP-4 keypanel cannot establish data communications with the intercom system, asterisks will continue to display. Check the intercom cable connections (in particular, the data connections).

Several symptoms may occur if the keypanel address is incorrectly set:

1. There may be no indication when there is an incoming call.
2. When an intercom key is pressed to talk, the destination may not hear the audio.
3. The call waiting display may behave erratically.

If any of these symptoms occur, recheck the keypanel address switch setting.

Always reset the RKP-4B after changing the address setting. Do this by cycling power on the base station.

### Assigning Intercom Keys

You can assign RKP-4 intercom keys using AZedit. For help with key assignment in AZedit, click the KP button on the program’s toolbar, then press the F1 key on the computer keyboard for help.

You can also assign keys at the keypanel, with the following exceptions:

1. Special functions (auto follow, auto listen, etc.) cannot be assigned.
2. You can only assign one destination to each talk key (talk level 1). If you need to assign special functions, or activate two destinations with a single talk key (talk level 1 and talk level 2) you must assign the key using AZedit.

If you assign talk level 1 from the keypanel, it will erase any talk level 2 assignment that you previously assigned using AZedit.

Assign intercom keys at the RKP-4 as follows:

1. Make sure the key that you want to assign is off.
2. Press the <SCROLL UP> or <SCROLL DOWN> key to view the list of intercom names in the call waiting window.
  - a. If you start by pressing Scroll Up, the list will start with the top of the point-to-point names. If you start by pressing scroll down, the list will start with the bottom of the point-to-point names. Examine or assign a name from a different scroll list as follows:
    - i. Make sure that the CWW (call waiting window) is clear. (Dashes should display.) Tap <COPY> then <LISTEN 4> to clear CWW.
    - ii. Tap <COPY> and then tap the <SCROLL UP> button. The CWW displays ‘ASGN’ for key assignments. (See “Displaying Key Assignments” in this section for more information on assignment viewing). Click on the <SCROLL UP> or <SCROLL DOWN> button to go through the different scroll lists available.
    - iii. To select a particular scroll list, tap the <COPY> button.
    - iv. You can go through the names in the selected scroll list by tapping the <SCROLL UP> or <SCROLL DOWN> button.
    - v. Tap the <COPY> key then <LISTEN 4> to return to normal operation.

**NOTE:**

- You can scroll one name at a time by clicking and immediately releasing the <SCROLL UP> or <SCROLL DOWN> button. If you press and hold the button it will start scrolling slowly through the names. After a few seconds the scroll speed will increase. This is useful when you need to scroll through a long list.
- The following types of names may not appear in the scroll list: UPL Resources, IFB's Relays (GPI outputs), and ISO's. This is because the scroll enable check boxes for these items may not be checked in AZedit. If you don't know how to activate these check boxes, proceed as follows: Run AZedit. Then, press the F1 key on your computer for help. Click the Search button in help, and type "UPL Resources" or "IFB", etc. (without the quote marks). From the list of available help topics, select any topic that tells you how to access or set up the item that you typed. For example, there is a topic that tells you how to access UPL Resources. Once you access UPL Resources, again press the F1 key for help. Within the new help screen, you should find help with the scroll enable feature.
- 3. When the name you want to assign is displayed in the call waiting window, release the Scroll button.
- 4. Press and hold the <COPY> button, then tap on an intercom key to assign talk, or tap on a listen key to assign listen. The talk or listen LED will blink once to confirm the assignment.

**NOTE:**

To assign both talk and listen, continue holding the Copy button while tapping each key.

- 5. Press <COPY> then <LISTEN 4> to return to normal operation after assigning keys. Otherwise, if you do nothing, the RKP-4 will automatically return to normal operation after about 15 seconds.

## Clearing Key Assignments

1. Make sure that the key or keys that you want to clear are turned off.
2. Tap the <COPY> then <LISTEN 4>. This clears the call waiting display. (Dashes should display).
3. Press and hold the <COPY> button, then tap the intercom key that you want to clear. The talk or listen LED will flash to confirm that the key assignment is cleared. You can tap several keys in succession to clear them while continuing to hold down the <COPY> button.

## Changing Setup Pages

There are four setup pages available. Each setup page can contain a complete set of key assignment. By changing the setup page you can therefore quickly change all of the keys assignments. Change the setup page as follows:

1. Make sure all intercom keys are off.
2. Tap the <COPY> then <LISTEN 4>. This clears the call waiting display.
3. Press both scroll up and down. The currently assigned setup page will display in the call waiting window. Tap <LISTEN 1> for PG1, <LISTEN 2> for PGP2, <LISTEN 3> for PG3, and <LISTEN 4> for PG4.
4. Tap <COPY> to accept the currently displayed page.
5. Tap <COPY> then <LISTEN 4>.

## Momentary vs. Latching Operation

For momentary key activation, press and hold an intercom key. For latching operation, tap the key to turn it on, and tap it again to turn it off.

- If the key's LED does not turn on when the key is activated, this means the key is not currently assigned.
- The electronic latching feature must be enabled in order to use latching. See "RKP-4B Operation" section for details.

## Intercom Key Operation for Different Types of Key Assignments

**Basic Talk and/or Listen Key Operation:** The lower button activates talk (if assigned). The upper button activates listen (if assigned). Talk and listen may be latched on or off independently by tapping up or down.

### NOTE:

The following paragraphs describe special types of key assignments called special functions. These types of key assignments can only be set up using the AZedit software, and they are described in detail in the software help file. To find out if a key has a special function assignment, you can display the key's assignment as described under "Displaying Key Assignments". If a special function is assigned to a listen key, you will see AF, or AL, etc. when you display the key assignment.

**Talk+Auto-follow (AF) Listen Key Assignment:** This key assignment works the same as the basic talk/listen key assignment: The down position activates talk, and the up position activates listen. Talk and listen may be turned on or off independently by pressing up or down.

**Talk+Auto-Listen (AL) Listen Key Assignment:** The down position activates both talk and listen. However, only the talk LED will turn on. If talk is on, you cannot turn off listen. If talk is off, you can turn listen on independently by pressing up.

**Talk+Auto-mute (AM) Listen Key Assignment:** The down position activates talk. And, if listen is on, it automatically turns off until talk is released. When talk is off, listen may be turned on independently by pressing up.

**Talk+Auto-reciprocal (AR) Listen Key Assignment:** The down position activates talk. Listen is always on and continuously monitors whatever is assigned to the talk position.

## Talk+Auto-reciprocal (AR) Listen Key Assignment:

The down position activates talk. Listen is always on and continuously monitors whatever is assigned to the talk position.

**All Call (AC) Talk Key Assignment:** When a talk key is assigned as an All Call key, it operates only as a switch to turn on or off all talk keys to the left of the All Call key. These other talk keys will then activate according to the way they have been assigned. Note that will also affect any listen keys that have been assigned with special functions. For example, an auto listen key will also activate if its corresponding talk key has been activated by an All Call key.

## Intercom Key Indications

### Talk Indicator:

- Solid green: Talk is activated.
- Green flashing "incoming call" indication: The person assigned to the key is calling. Activate the key to talk back.
- Continuous red "in use" indication: An "in-use" indication is provided for an IFB or ISO key. It is also provided for a key that talks to a remote intercom system (when your intercom system is equipped with optional trunking). The "in-use" indication warns you that someone else is currently talking
- Red flashing "busy" indication; May occur when a key is activated to talk to an IFB or a remote intercom system. This indicates that some other keypanel with a higher priority is currently talking and you cannot talk at this time.

### Listen Indicator:

- Solid red: Listen is activated. (This indication will only be provided when you manually turn listen on by tapping or pressing upward on a key. It will not occur.

### GPIO

- If the relay button is enabled at the RKP-4, then whenever the button is activated a GPI instruction will be sent to the matrix. This instruction is sent regardless of whether the relay is enabled or disabled via the software menu at the base station. This GPI may be used as conditions for UPL statements in AZedit.

## Call Waiting Operation for Incoming Calls

As previously described, the talk indicator for a key will flash when there is an incoming call to that key, and you may activate that key to talk back. Also if display call is set to enable at the base, the caller's name will appear in the call waiting window, and you may press down on the call waiting key instead to talk back. If a caller is not already assigned to an intercom key, the caller's name will always appear in the call waiting window, and you must use only the call waiting key to talk back.

If a second call is received in the call waiting window while a caller's name is already displayed there, the call waiting display will start to flash. Also, the topmost LED next to the call waiting key will turn on. When there are multiple calls, use the call waiting key as follows:

1. To talk to the currently displayed caller, tap <COPY> then <TALK 4>.
2. To clear the currently displayed caller name, briefly tap <COPY> then <LISTEN 4>. The next caller's name will then appear in the call waiting window, and you may tap <COPY> then <TALK 4> to talk back.
3. Continue talking to callers and clearing their names until the call waiting window displays dashes (no callers). Also, when all calls have been answered, the CWW backlight will turn off and dashes will be displayed. The RKP-4 system cannot answer calls from TIF-951 and TIF-2000 telephone interfaces.

### NOTE: Call Waiting Buttons

Due to limited top panel space on the RKP-4, the talk 4 button is also used as the call waiting talk button. Whenever <COPY> is tapped, for the next 2 seconds talk 4 is the call waiting talk button and listen 4 is clear.

## Displaying Key Assignments

You can use this feature to check key assignments after making changes. You can also use it if you think the key assignments have been changed but the designation strip has not been updated.

1. Tap <COPY> then <LISTEN 4> to clear the call waiting window. (Dashes should display when the window is clear.)
2. Tap <COPY> then press the <UP> button. 'ASGN' should display in the call waiting window. Press talk or listen key to display the talk or listen assignment. You may press several keys in succession to check their assignments.
3. Tap <COPY> to exit.

## Quick List of Matrix Key Functions

The following list is the most often used RKP-4 button functions.

### Matrix Key Functions

- Clear CWW = <COPY> then <LISTEN 4>
- Answer a CWW call = <COPY> then <TALK 4>
- Call Back = <COPY> then <TALK 4>
- Display Scroll Lists = <COPY> then <UP>; <UP> or <DOWN> for lists.
- Select desired scroll list = <COPY>
- PTP Scroll List = <UP> or <DOWN> for top or bottom of list
- Assign a Key to a Scroll List Entry = Hold <COPY> and hit desired Talk or Listen button
- Show a Key's Assignment = <COPY> then <UP>; CWW displays 'ASGN'. Press talk/listen keys for current assignment.
- Select Setup Page = <UP> + <DOWN> then hit listen button 1 to 4 for pages 1 to 4. Tap <COPY> to change.

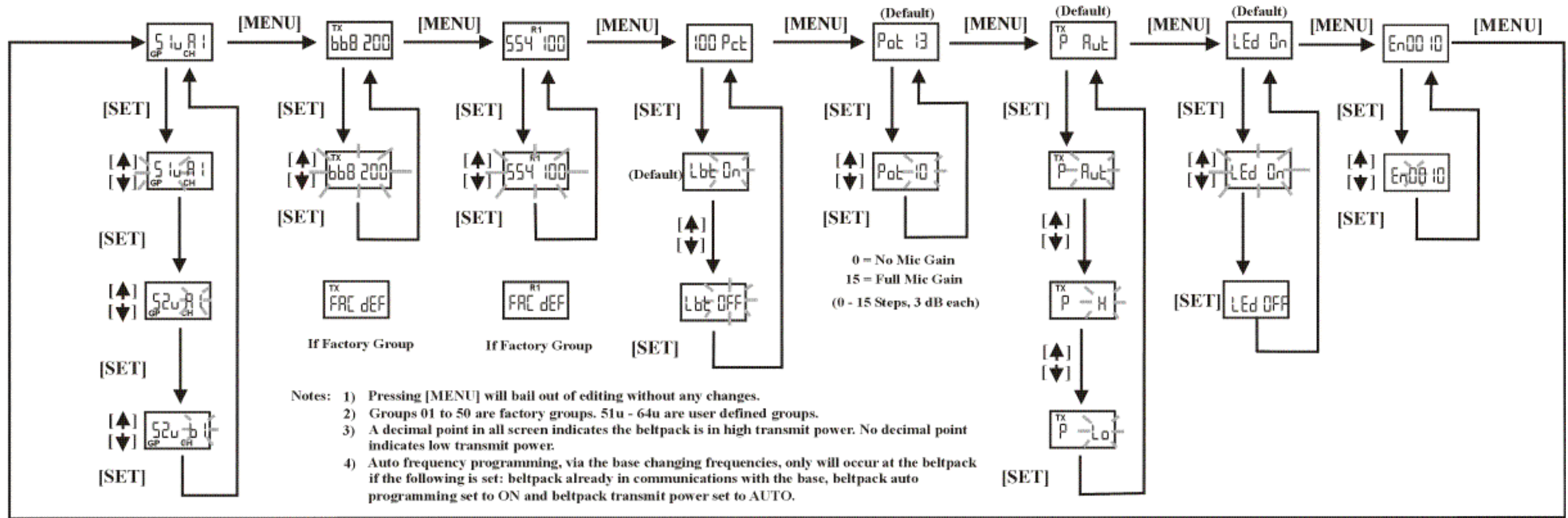

Software / Ch Maps	"Relay" Button	Clear Scan	Serial Number Set	Lock Out	1st Use	Factory Reset	Auto Program
<p>Hold [▼] for 3 seconds</p> <p>590 026</p> <p>Release [▼]</p> <p>c 0000 1</p> <p>Displayed for 2 seconds</p> <p>40000 1</p> <p>Displayed for 2 seconds Then back to last menu screen</p>	<p>Hold [SET] and hit relay</p> <p>(Default) c P t R</p> <p>Hit c L A t</p> <p>Hit c O F F</p>	<p>Hold [MENU] + [SET] for 3 seconds</p> <p>Scan for Best Gp. CS 9P</p> <p>Scan for Best Ch. CS ch CH</p> <p>Scan Band CS R1 bnd</p>	<p>Must be in Encrypt Set Screen</p> <p>[MENU] + [▲] for 3 seconds</p> <p>Sn 1050</p> <p>[SET]</p> <p>After last number is set it defaults back to Encrypt Screen</p>	<p>Hold [▲] + [▼] for 3 seconds to lock</p> <p>SECURE</p> <p>Hold [▲] + [▼] for 3 seconds to unlock</p> <p>ACCESS</p> <p>During Lock if [SET] hit</p> <p>LocOut</p>	<p>Hold [MENU] as Powering-up Unit</p> <p>Sets unit to Gp 01, Ch A1 All user settings kept</p>	<p>Hold [MENU] + [SET] + [▲] + [▼] for 3 seconds</p> <p>Sets unit to Gp 01, Ch A1 All user settings erased Set to factory defaults</p>	<p>Hit [▲] for 3 seconds</p> <p>Rut On</p> <p>Rut OFF</p> <p>[SET] (Default)</p>

Figure 9-1  
RKP-4 Menu Structure  
9-1

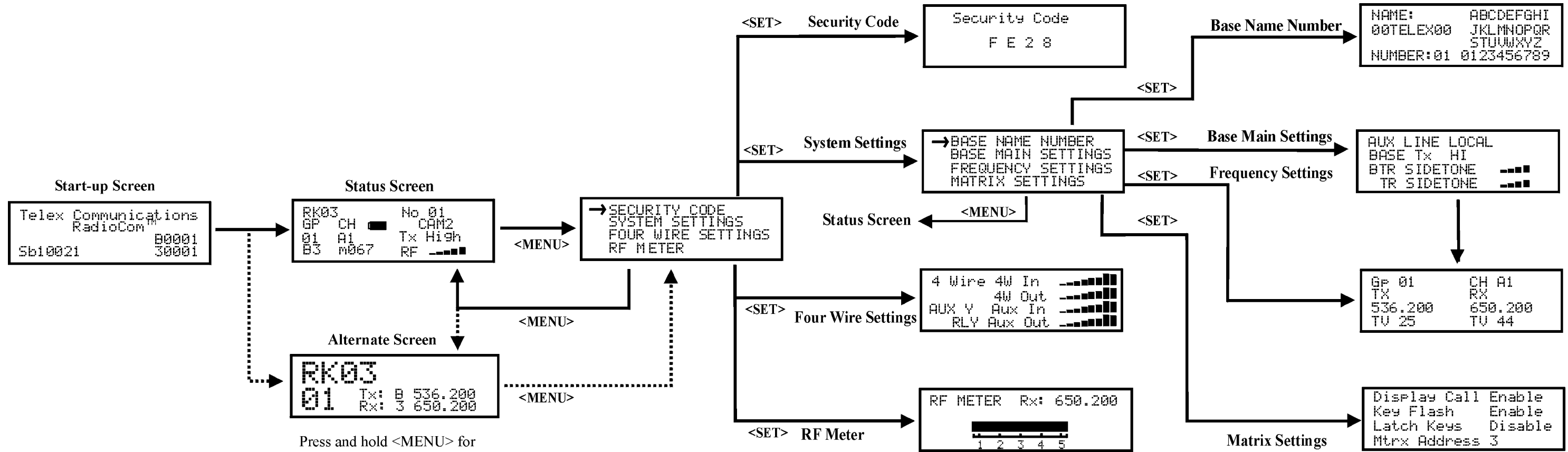

Press and hold <MENU> for 3 seconds to toggle between Status or Alternate for the screen in this position.

**NOTES:**  
 1. When the RK-4B is first powered-up, "00TELEX00" will be displayed in the name location (upper left) of the status screen. When the RKP-4B connects to the matrix, this name will change to the alpha given to the port where the RKP-4B is connected.  
 2. Pressing <MENU> once, after setting parameters in a non-menu screen, returns the unit to the status or alternate screen.

Figure 10-1  
RKP-4B Menu Structure

## Frequency Bands

The RKP-4B system operates in TV channels 16 to 36 and 38 to 59. This is the frequency range of 482 to 608 MHz and 614 MHz to 746 MHz. The band, TV channels and frequencies are shown in Table 2. Most bands are 18 MHz wide, however band 7 is 24 MHz wide.

Bands F to E are always base transmit bands (beltpack receive bands). Bands 1 to 7 are always base receive bands (beltpack transmit bands). Thus an A2 base station would be comprised of an A band transmitter paired with a 2 band receiver.

## Band Pairing for Systems

All band pairs cannot be made into a system (a single system is comprised of a base and beltpack). Table 1 show the available band pairings.

Base TX Bands	Base RX Bands
F	1, 2, 3, 4, 5, 6, 7
H	1, 2, 3, 4, 5, 6, 7
A	2, 3, 4, 5, 6, 7
B	3, 4, 5, 6, 7
C	4, 5, 6, 7
D	5, 6, 7
E	6, 7

Table 1  
Available Band pairings

In Table 1 it can be seen that a C base station transmit band can be paired with 4, 5, 6 or 7 receive bands. However, a C3 unit cannot be made. This is because a certain amount of frequency separation between transmit and receive bands is required for good transmit and receive operation. If they are too close the RF performance of the system is reduced.

Band	TV	Freq. Start	Freq. End
F	16	482	488
	17	488	494
	18	494	500
H	19	500	505
	20	506	512
	21	512	518
A	22	518	524
	23	523	530
	24	530	536
B	25	536	542
	26	542	548
	27	548	554
C	28	554	560
	29	560	566
	30	566	572
D	31	572	578
	32	578	584
	33	584	590
E	34	590	596
	35	596	602
	36	602	608
Not Used	37	608	614
1	38	614	620
	39	620	626
	40	626	632
2	41	632	638
	42	638	644
	43	644	650
3	44	650	656
	45	656	662
	46	662	668
4	47	668	674
	48	674	680
	49	680	686
5	50	686	692
	51	692	698
	52	698	704
6	53	704	710
	54	710	716
	55	716	722
7	56	722	728
	57	728	734
	58	734	740
	59	740	746

Table 2  
Band Names and TV Channels

## Factory Group Plan

There are 50 factory defined groups in a base station and belt-pack. These groups are organized in different ways to provide flexibility to the user on selecting frequencies. A group is composed of intermodulation free frequencies, but a group is also organized to be composed of frequencies in different combinations of the TV channels. The user then can select a group that is clear of broadcast TV channels in the area by selecting a group(s) that doesn't use those channels.

Table 3 indicates how the factory defined groups use the three TV channels for transmit and 3 TV channels for receive. A shaded TV channel indicates the group has frequencies in that channel. The white TV channel indicates the group has no frequencies in that TV channel. Group 1 uses at least one frequency from each of the three TV channels for TX and RX. However group 50 uses only the third TV channel for TX and RX.

Group	Base TX Freq.			Base RX Freq.		
	TV1	TV2	TV3	TV4	TV5	TV6
1	Shaded	Shaded	Shaded	Shaded	Shaded	Shaded
2	Shaded	Shaded	Shaded	Shaded	Shaded	Shaded
3	Shaded	Shaded	Shaded	Shaded	Shaded	Shaded
4	Shaded	Shaded	Shaded	Shaded	Shaded	Shaded
5	Shaded	Shaded	Shaded	Shaded	Shaded	Shaded
6	Shaded	Shaded	Shaded	Shaded	Shaded	Shaded
7	Shaded	Shaded	Shaded	Shaded	Shaded	Shaded
8	Shaded	Shaded	Shaded	Shaded	Shaded	Shaded
9	Shaded	Shaded	Shaded	Shaded	Shaded	Shaded
10	Shaded	Shaded	Shaded	Shaded	Shaded	Shaded
11	Shaded	Shaded	Shaded	Shaded	Shaded	Shaded
12	Shaded	Shaded	Shaded	Shaded	Shaded	Shaded
13	Shaded	Shaded	Shaded	Shaded	Shaded	Shaded
14	Shaded	Shaded	Shaded	Shaded	Shaded	Shaded
15	Shaded	Shaded	Shaded	Shaded	Shaded	Shaded
16	Shaded	Shaded	Shaded	Shaded	Shaded	Shaded
17	Shaded	Shaded	Shaded	Shaded	Shaded	Shaded
18	Shaded	Shaded	Shaded	Shaded	Shaded	Shaded
19	Shaded	Shaded	Shaded	Shaded	Shaded	Shaded
20	Shaded	Shaded	Shaded	Shaded	Shaded	Shaded
21	Shaded	Shaded	Shaded	Shaded	Shaded	Shaded
22	Shaded	Shaded	Shaded	Shaded	Shaded	Shaded
23	Shaded	Shaded	Shaded	Shaded	Shaded	Shaded
24	Shaded	Shaded	Shaded	Shaded	Shaded	Shaded
25	Shaded	Shaded	Shaded	Shaded	Shaded	Shaded
26	Shaded	Shaded	Shaded	Shaded	Shaded	Shaded
27	Shaded	Shaded	Shaded	Shaded	Shaded	Shaded
28	Shaded	Shaded	Shaded	Shaded	Shaded	Shaded
29	Shaded	Shaded	Shaded	Shaded	Shaded	Shaded
30	Shaded	Shaded	Shaded	Shaded	Shaded	Shaded
31	Shaded	Shaded	Shaded	Shaded	Shaded	Shaded
32	Shaded	Shaded	Shaded	Shaded	Shaded	Shaded
33	Shaded	Shaded	Shaded	Shaded	Shaded	Shaded
34	Shaded	Shaded	Shaded	Shaded	Shaded	Shaded
35	Shaded	Shaded	Shaded	Shaded	Shaded	Shaded
36	Shaded	Shaded	Shaded	Shaded	Shaded	Shaded
37	Shaded	Shaded	Shaded	Shaded	Shaded	Shaded
38	Shaded	Shaded	Shaded	Shaded	Shaded	Shaded
39	Shaded	Shaded	Shaded	Shaded	Shaded	Shaded
40	Shaded	Shaded	Shaded	Shaded	Shaded	Shaded
41	Shaded	Shaded	Shaded	Shaded	Shaded	Shaded
42	Shaded	Shaded	Shaded	Shaded	Shaded	Shaded
43	Shaded	Shaded	Shaded	Shaded	Shaded	Shaded
44	Shaded	Shaded	Shaded	Shaded	Shaded	Shaded
45	Shaded	Shaded	Shaded	Shaded	Shaded	Shaded
46	Shaded	Shaded	Shaded	Shaded	Shaded	Shaded
47	Shaded	Shaded	Shaded	Shaded	Shaded	Shaded
48	Shaded	Shaded	Shaded	Shaded	Shaded	Shaded
49	Shaded	Shaded	Shaded	Shaded	Shaded	Shaded
50	Not Shaded	Not Shaded	Shaded	Not Shaded	Not Shaded	Shaded

**Table 3**  
**Groups and TV Channel Used**  
 Shaded = TV used,  
 Not Shaded = TV not used.



# Section 12

## Troubleshooting

Reread the sections of this manual to make sure you have completed system set-up properly.

If you are unable to solve the problem, contact the dealer from whom you purchased the system for assistance.

<b>PROBLEM</b>	<b>SOLUTION</b>
<b>DISTORTION</b> - System's audio quality seems distorted at medium to high input levels.	Reduce microphone gain by adjusting microphone gain control.
<b>HISS</b> - System seems to produce a "hiss" which is undesirable.	Check the gain setting on all beltacks and the base station. They may be too low to too high. Check to make sure you are still well within range of the base station.
<b>LOW OUTPUT</b> - System produces a low output level.	Check the gain setting on both the beltacks and the base station. They may be too low.
<b>FEEDBACK</b> - Moving around area of use produces "squeal" or "howl" in various locations using ext. speakers.	Reduce the gain setting on both the beltacks and the base station. They may be too high. If in the 2W Mode, the intercom channel you are on may be unloaded.
<b>DROPOUTS</b> - When moving around the area of use there seems to be locations where the signal "swooshes" or completely disappears.	Make sure both antennas on the base station and beltack are connected and follow the location suggestions. Change the location of the base station and antennas or avoid the bad areas with the beltacks.
<b>NO AUDIO</b> from BASE STATION or BELTACK headsets.	Check talk LED to make sure it is on. Make sure beltack batteries are OK. Make sure the base station and the beltack serial number and encryption codes all match.
<b>****</b> - Appear in BELTACK call waiting window when connected to the Matrix.	Check that cable is in "Matrix" jack on the rear panel of the base station. Check cable connection to Matrix. Make sure base station Matrix address is set to correct port on Matrix.



# Section 13

## Battery Information

---

Improper battery selection, use, installation and care are the cause of numerous wireless system failures.

**Alkaline Batteries:** Alkaline batteries such as Mallory's DURACELL® or Eveready's ENERGIZER® provide the most reliable operation in wireless transceivers.

**The use of low cost carbon-zinc batteries is NOT recommended.**

**Nickel-Metal Hydride Batteries:** These batteries can save you money in the long run, as they can be recharged. Typical battery life is about 90% of the length of time alkaline batteries last.

### Cold Temperatures and Batteries

The battery life times listed in this section are at room temperature. Alkaline and Nickel-Metal Hydride batteries service hours falls off significantly at low temperatures due to battery chemistry. Alkaline batteries typically have less than half their room temperature service life if used at freezing 32° F (0° C). Due to the service hours reduction of Alkaline and Nickel Metal Hydride batteries at low temperature the user will need to change batteries more often.

Another solution is using Lithium AA cells if beltpacks are to be used in very cold temperatures. Lithium batteries, like the Energizer® E2 Lithium AA cells, are excellent batteries at cold temperatures. At the temperatures of 15° F (-9° C), Lithium AA cells will last about 7 times longer than Alkaline batteries. that equates to 2 hours for Alkaline vs 14 hours for Lithiums. However, the tradeoff is Lithiums cost more and are less friendly to the environment than alkalines.

### Battery Life:

#### RKP-4

Alkaline, 8-10 hours typical  
Nickel Metal Hydride, 7-9 Hours typical

#### WARNING:

Do not place an alkaline RKP-4 battery pack in any battery charger. Severe charger and battery pack damage may result.

Energizer® is a registered trademark of Union Carbide Corporation.  
Duracell® is a registered trademark of Duracell Inc.



# Section 14

## RKP-4B to Matrix Cable

RJ12 to RJ12 Intercom Cable Wiring Diagram

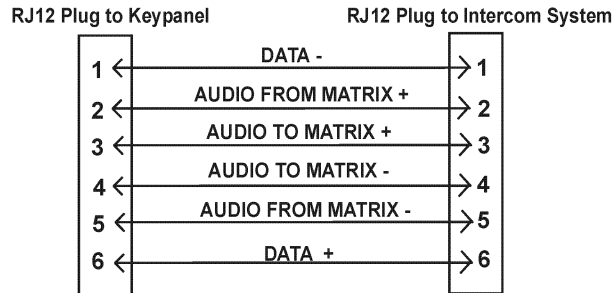
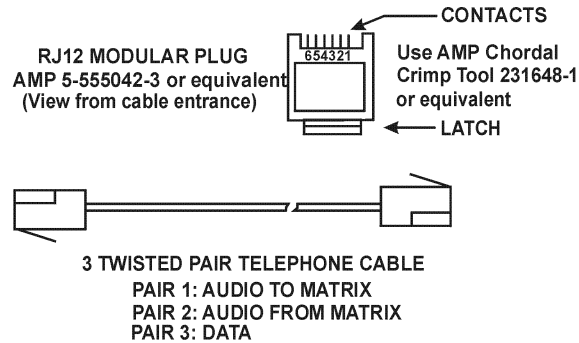
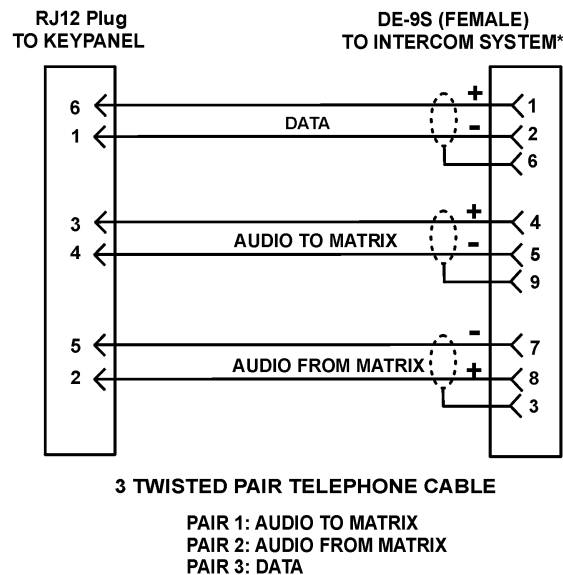

Figure 14-1  
RJ12 Intercom Cable Wiring Diagram

RJ12 to 9-pin Intercom cable wiring diagram



**IMPORTANT!**

\* When connecting to an ADAM CS back panel, use only low-profile cable connectors such as AMP Part No. 747516-3 (Telex Part No. 59926-678)

Figure 14-2  
RJ12 to 9-pin Intercom Cable Wiring Diagram



### FCC LICENSING

The Telex RKP-4B and the RKP-4 Transmitter/Receiver are Type Accepted under United States Federal Communications Commission Part 74. Licensing of Telex equipment is the User's responsibility and licensibility depends on the user's classification, users application, and frequency selected. Telex strongly urges the user to contact the appropriate telecommunications authority for any desired clarification.

This device complies with part 15 of the FCC Rules. Operation is subject to the condition that this device does not cause harmful interference.

**CAUTION:** Changes or modifications made by the user could void the user's authority to operate the equipment.





### **End-User License Agreement for Telex® Software**

**IMPORTANT** - Please read this document carefully before using this product.

THIS DOCUMENT STATES THE TERMS AND CONDITIONS UPON WHICH TELEX COMMUNICATIONS, INC. (the "COMPANY") OFFERS TO LICENSE THE INSTALLED SOFTWARE OR PROGRAM (the "SOFTWARE") FOR USE WITH THE PRODUCT IN WHICH IT WAS INSTALLED. YOU ARE AGREEING TO BECOME BOUND BY THE TERMS OF THIS AGREEMENT. IF YOU DO NOT AGREE TO THE TERMS OF THIS AGREEMENT, DO NOT USE THIS PRODUCT. PROMPTLY RETURN THE PRODUCT TO THE PLACE WHERE YOU OBTAINED IT FOR A FULL REFUND.

The installed software as supplied by the Company is licensed, not sold, to you for use only under the terms of this license, and the Company reserves all rights not expressly granted to you. You own the product or other media on or in which the Software is originally or subsequently recorded or fixed, but the Company retains ownership of all copies of the Software itself.

1. **License:** This license allows you to use the Software for internal purposes only on a single product in which it was installed.
2. **Restrictions:** (a) You may not market, distribute or transfer copies of the Software to others or electronically transfer or duplicate the software. YOU MAY NOT REVERSE ENGINEER, DECOMPILE, DISASSEMBLE, MODIFY, ADAPT, TRANSLATE, RENT, LEASE OR LOAN THE SOFTWARE OR CREATE DERIVATIVE WORKS BASED ON THE SOFTWARE OR ANY ACCOMPANYING WRITTEN MATERIALS. (b) The Software and the accompanying written materials are copyrighted. Unauthorized copying of the Software, including portions thereof or the written materials, is expressly forbidden. (c) You understand that the Company may update or revise the Software and in so doing incurs no obligation to furnish such updates to you.
3. **Limited Warranty:** The company does not warrant that the operation of the Software will meet your requirements or operate free from error. The company **DISCLAIMS ALL OTHER WARRANTIES AND CONDITIONS EITHER EXPRESS OR IMPLIED, INCLUDING THE WARRANTIES OF MERCHANTABILITY, FITNESS FOR A PARTICULAR PURPOSE AND NON-INFRINGEMENT OR THIRD PARTY RIGHTS.**
4. **Limited Liability:** The liability of the company for any claims arising out of this License based upon the Software, regardless of the form of action, shall not exceed the greater of the license fee for the Software or \$50.



# Section 17

## Accessories and Replacement Parts

### ALP-600

480-800 MHz Bi-Directional Log Periodic Antenna Includes mounting hardware and 10 feet (3 meters) of coaxial cable with TNC Connectors

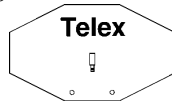

P N. 878896

### ALP-450

450-900 MHz Log Periodic Antenna Includes mounting hardware and 10 feet (3 meters) coaxial cable with TNC connectors

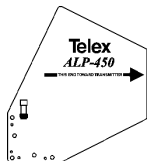

Order No. 71147000

### AB-2

Bracket for 1/2 wave Antenna with 10 ft. of coax-

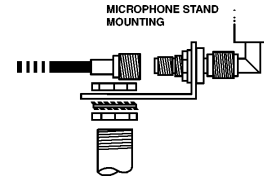

PN 71138000

### RPK-4B Power Supply

12 VDC, 1 AMP .....879963

### RPK-4B Power Cords

U.S./Canada ..... 600092

RPK-4 LCD/ switch cover .....450364

2 Pin Relay Connector .....2862046

### BP-700 TR Battery pack, alkaline

(batteries not included) .....71315-000

### BP-700NM TR Nickel Metal Hydride

Battery pack .....71315-001

### BC-1NM4

Four Slot "Smart" Charger with Four Nickel Metal Hydride Battery Packs

U.S./Canada .....301778400

Euro .....301778401

### BC-1NM

Single Slot "Smart" Charger with Nickel Metal

Hydride Battery Pack

U.S./Canada .....301778100

Euro .....301778101

### Antenna Cables

Special low loss antenna cables with TNC Connectors

Model No.	Length	Order No.
CXU-22	Ft. (.7 meter)	691459-8
CXU-10	10 Ft. (3 meter)	690419
CXU-25	25 Ft. (7.6 meter)	71151-025
CXU-50	50 Ft. (15 meter)	71151-050
CXU-75	75 Ft. (23 meter)	71151-075
CXU-100	100 Ft. (30 meter)	71151-100

### Base Station:

Flexible Ground Independent Dipole Antennas



Model No.	Part No.	Band Color	Frequency
FA-RW	EML000106RW	Red/White	470-550 MHz
FA-YW	EML000106YW	Yellow/White	525-610 MHz
FA-GW	EML000106GW	Green/White	610-710 MHz
FA-BW	EML000106BW	Blue/White	710-880 MHz

### Beltpack's 1/4-wave antenna

Part No.	Color Dot	Frequency
879220-1	Violet	425-485 MHz
879220-2	Black	485-556 MHz
879220-3	Yellow	556-636 MHz
879220-4	Green	636-726 MHz
879220-5	Red	726-826 MHz

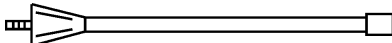





**Telex<sup>®</sup>**

BOSCH SECURITY SYSTEMS • 12000 Portland Ave. South, Burnsville, MN 55337

PN 804130-TX Rev. D

Feb 2010

Made in U.S.A.